

Foreword

Introduction to the Owner's Handbook

Instructions for Use

Thank you for purchasing the product. Please read this handbook carefully since the information in it may allow you to know how to operate your vehicle safely and properly, and enjoy your driving pleasure at maximum from it.

This handbook is applicable to CSA6492LBEV2, CSA6492LBEV3, CSA6492LBEV5 and CSA6492LBEV6 series passenger cars.

The model products of these series follow the enterprise standards Q/SAIC043004-2023 and Q/SAIC043005-2023. This handbook describes various features and functions of the vehicles within above model range.

This handbook includes the up-to-date product information available at the time of release, and the company has the full authorities to take charge of the amendments, explanations and statements of this handbook.

Announcement

The User's Handbook and Owner's Handbook introduce how to use your vehicle properly, precautions in use, and how to service and maintain your vehicle correctly. Meanwhile, they are intended to identify agreements between the company and owners on creation and termination for related product quality assurance liabilities as well as after sales service rights and duties. Please read the User's Handbook and Owner's Handbook carefully before using any products of the company.

Please always use accessories, parts and oils & fluids in conformity with technical specifications and quality standards and applicable to the vehicle, and maintain and service your vehicle in accordance with correct operation procedures. For better maintenance and service of your vehicle, you are recommended to consult an Authorised Repairer. Please respect intellectual property and use genuine accessories, parts, etc. If any accessories and parts which may infringe intellectual property are used, you will probably bear corresponding legal risks and legal consequences.

Any damage resulting from misuse, negligence, wrong use or unauthorised modification may invalidate your right of claim. If a vehicle is damaged or incurs an accident due to the use of any accessories, parts or oils & fluids not in conformity with technical specifications and quality standards or misuse or due to improper service and maintenance, its user will also lose his/her claim for damage compensation, and the company will not bear corresponding liabilities.

Various countries and regions impose strict restrictions on vehicle modification and add-on. It is not allowed to change the vehicle structure, framework or features without approval, otherwise it will affect traffic safety, vehicle operation, vehicle registration or public security management. It will not only cause malfunction or reduce performance of the related components, but also bring the harm and life-threatening risk to the driver and the passengers if parts of the vehicle are modified or altered without permission.

No part of this publication may be reproduced, stored in a retrieval system or transmitted in the form of electronic, mechanical recording or other means without prior written permission from the company.

Symbols Used

Warning

Warning: This warning symbol identifies procedures that must be followed precisely, or information that must be considered with great care, in order to reduce the risk of personal injury or serious damage to the vehicle.

IMPORTANT

IMPORTANT

The statements stated here must be followed strictly, otherwise your vehicle could be damaged.

Note

Note: This describes helpful information.



This symbol indicates parts described must be disposed of by authorised bodies to protect the environment from unnecessary damage.

Asterisk

An asterisk (*) appearing after the title or the text identifies features or items of equipment that are only fitted to some models, and may not be fitted on the vehicle you purchased.

Illustrations

The illustrations in this Handbook are for reference only.

The information contained may vary slightly depending on the vehicle configuration, software version and sales regions.



Identifies components being explained.



Identifies movement of components being explained.

Precautions for Using Electric Vehicles

High-voltage System

Danger

- There are two kinds of high voltage power supplies (AC and DC) in the high voltage system. These high voltage system components are attached with warning labels of high voltage system. Please always observe the requirements on the labels.
- To avoid personal injury, non-professional maintenance personnel are prohibited from contacting, dismantling or fitting any component of the high-voltage system without permission.

High-voltage system components layout - 400V

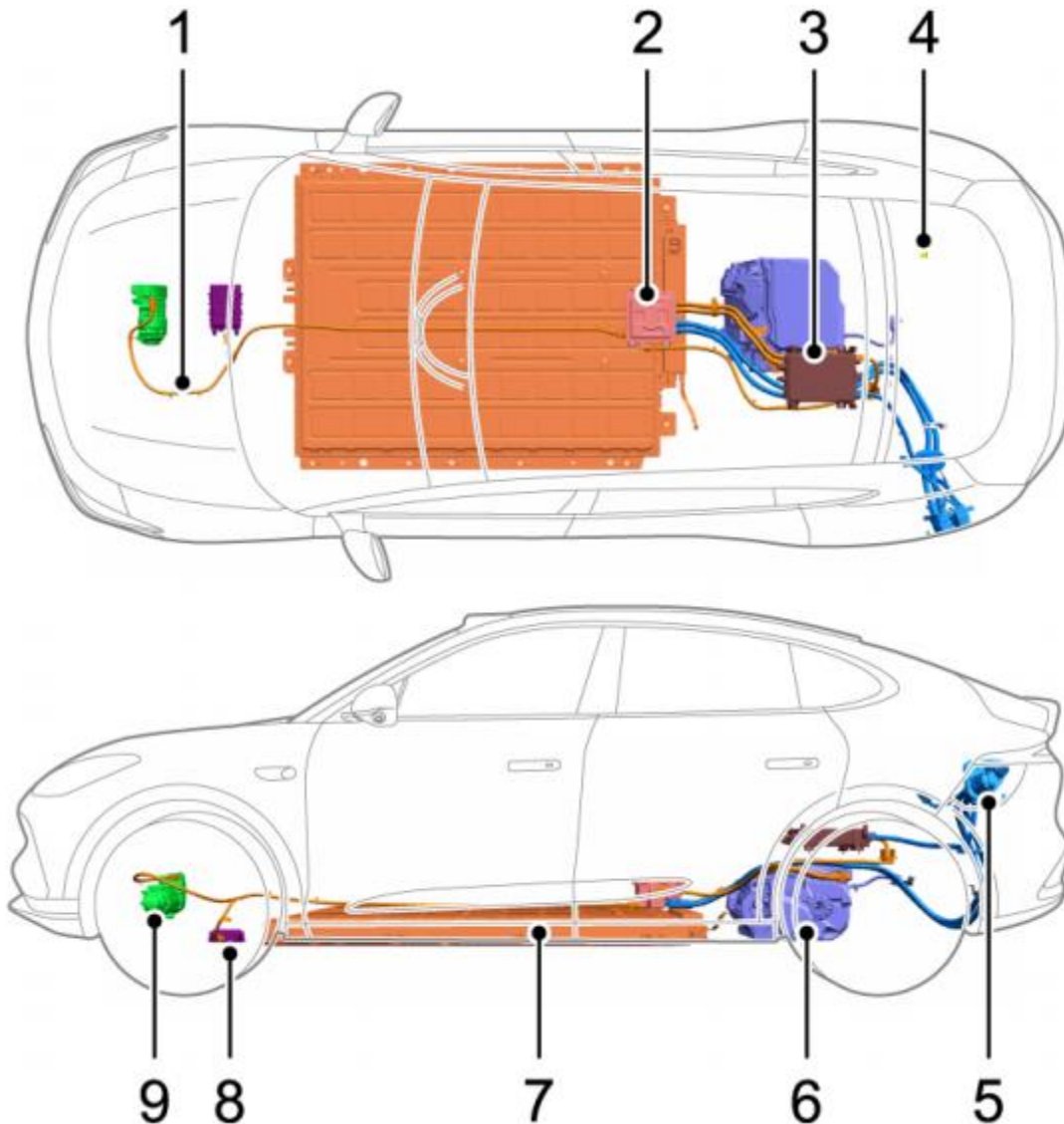

1. High-voltage harness
2. High-voltage power distribution unit
3. Combined charging unit
4. Manual service disconnect (MSD)
5. Charging port
6. Rear electric drive unit
7. High-voltage battery pack
8. Battery heater
9. Electric A/C compressor

High-voltage system components layout - 800V

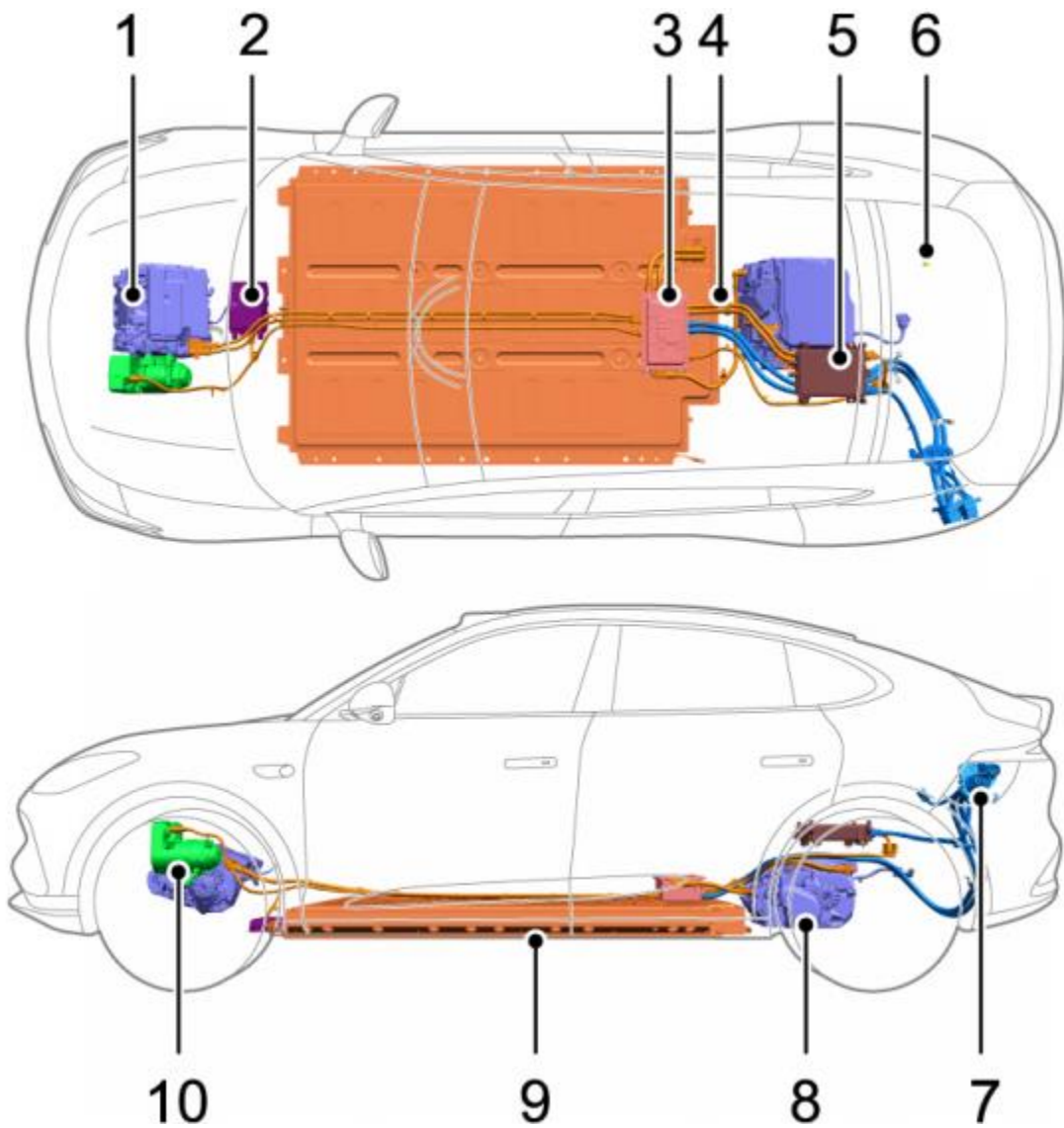

1. Front electric drive unit*
2. Battery heater
3. High-voltage power distribution unit
4. High-voltage harness
5. Combined charging unit
6. Manual service disconnect (MSD)
7. Charging port
8. Rear electric drive unit
9. High-voltage battery pack
10. Electric A/C compressor

Precautions in the Event of an Accident

- Keep the shift lever in P position, and turn off the vehicle power supply.
- If the wires are exposed, do not touch any of them, to avoid electric shock.
- If the vehicle is on fire and the fire is small and slow, carbon dioxide extinguisher can be used to put out the fire, and contact the fire department as soon as possible. If the fire is big and quick, the user should immediately stay away from the vehicle and contact the fire department.
- In case of a collision, the vehicle is not allowed to be started again, and the 12V low-voltage battery negative terminal and the manual service disconnect should be disconnected before rescue.
- When the vehicle is completely or partially submerged in water, the user should turn off the vehicle power supply and escape from the vehicle timely. The 12V low-voltage battery negative terminal and the manual service disconnect should be disconnected before transporting the salvaged vehicle. If there is no bubble or sizzle sound while salvaging, the vehicle salvaging can be continued. If there are bubbles or sizzle sound, the salvaging should be suspended until no bubble or sizzle sound emits. At this time, there is no risk of electric shock when touching the body or structure of the vehicle in or out of water.
- Please contact an Authorised Repairer for service after the accident is handled.
- The vehicle is provided with a rescue information card. Please show the card to the rescue personnel when they arrive.
- If the accident causes damage to vehicle body, when it is required to conduct cutting, welding and paint spraying for sheet metals, in order to avoid damage to high-voltage battery pack, please contact an Authorised Repairer, and conduct related operations after removal of high-voltage battery pack.

Driving Range

The driving range of your vehicle depends on the quantity of available electricity, vehicle age (current remaining battery life), weather, temperature, road conditions and driving habit etc.

Caution:

- The driving range is related to the depth of discharge (DOD). When the low battery warning lamp of high-voltage battery pack on the instrument pack illuminates, please recharge the battery as soon as possible to avoid high DOD affecting the performance of high-voltage battery pack.
- The actual driving range of the vehicle will reduce with the increase of vehicle age.
- The use of air conditioning will reduce the driving range.
- The driving range varies with the speed.
- When the vehicle is used at low temperatures, the driving range will decrease due to temperature characteristics of the battery.
- In the case of extreme temperature and low battery, weak acceleration or lack of power may occur due to battery characteristics.

The driving range can be increased by:

- Having the vehicle maintained regularly;
- Maintaining proper tyre pressures;
- Using the vehicle as few as possible at high or cold temperatures.
- Recharging the vehicle after use, without parking for a long period of time in winter.
- Reducing the vehicle load by removing unnecessary items;
- Turning off high-power electrical appliances such as the air conditioning, or adjusting the heating or cooling base temperature as necessary to minimise the energy consumption and increase the driving range.
- Closing the windows under the condition that the vehicle is running at a high speed, so as to reduce air resistance as well as power consumption.
- Keeping a steady speed.
- Depressing the accelerator pedal as lightly as possible while accelerating.
- Releasing the accelerator pedal while decelerating; under certain conditions when not applying the brake or gently applying the brake, the kinetic energy recovery system (KERS) will extend the driving range.

Use of High-voltage Battery Pack

Ambient Temperature for Using Vehicle

Since the performance of the high-voltage battery pack in the power system is related to the ambient temperature, the vehicle should be used within the temperature range of $-15^{\circ}\text{C}\sim 45^{\circ}\text{C}$, so as to ensure the vehicle in the best working status and to extend the service life of the high-voltage battery pack. Extremely high or low temperatures will affect the performance of the high-voltage battery pack and vehicle.

Equalisation Charging

In order to assist in extending the service life of the high-voltage battery pack, it is recommended that AC charging should be used to reach full state of charge once at regular intervals to allow the equalisation of battery pack.

After equalising charge, the voltage of each battery cell is basically the same, so as to ensure the overall performance of high-voltage battery pack.

Crash Outage Control

If a crash occurs, a signal from the SDM will disconnect the relays within the high-voltage battery back to cut off the high-voltage output of the high-voltage battery pack.

12V Battery Automatic Charging Function

When the vehicle is powered off and the system detects that the 12V battery is running low, the vehicle will automatically charge the 12V battery under certain safety conditions to prevent the vehicle from failing to start due to low battery. This function will be automatically turned off upon completion of charging.

Note: When the system detects a fault/vehicle starting/charging with an external device, it will automatically exit the 12V battery automatic charging function.

Note: When the system automatically charges the 12V battery, the driving range of the vehicle will be reduced.

Note: This function will be temporarily disabled when the high-voltage battery pack is running low.

Before Using the Vehicle

Vehicle Overview

Appearance Introduction

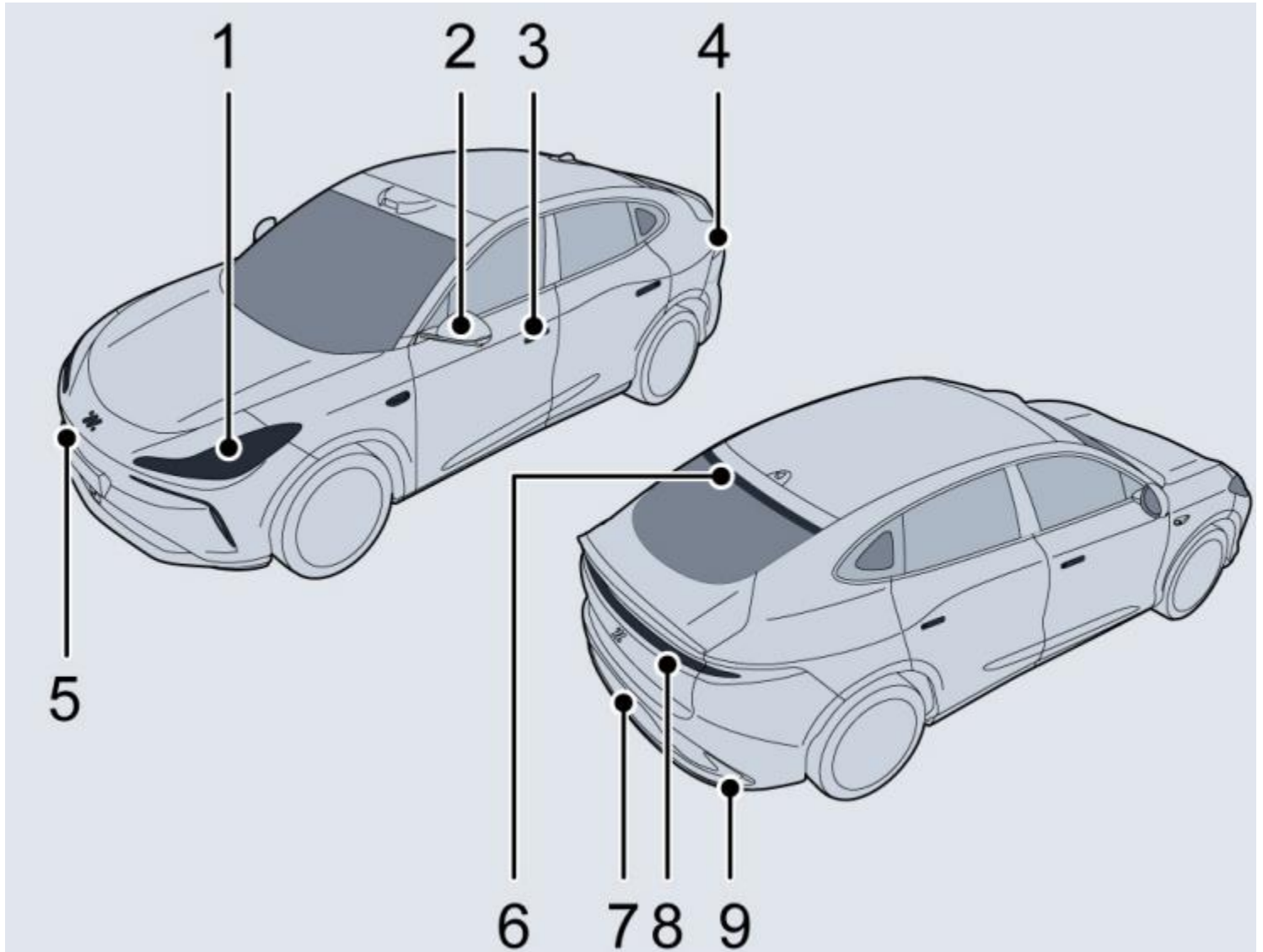





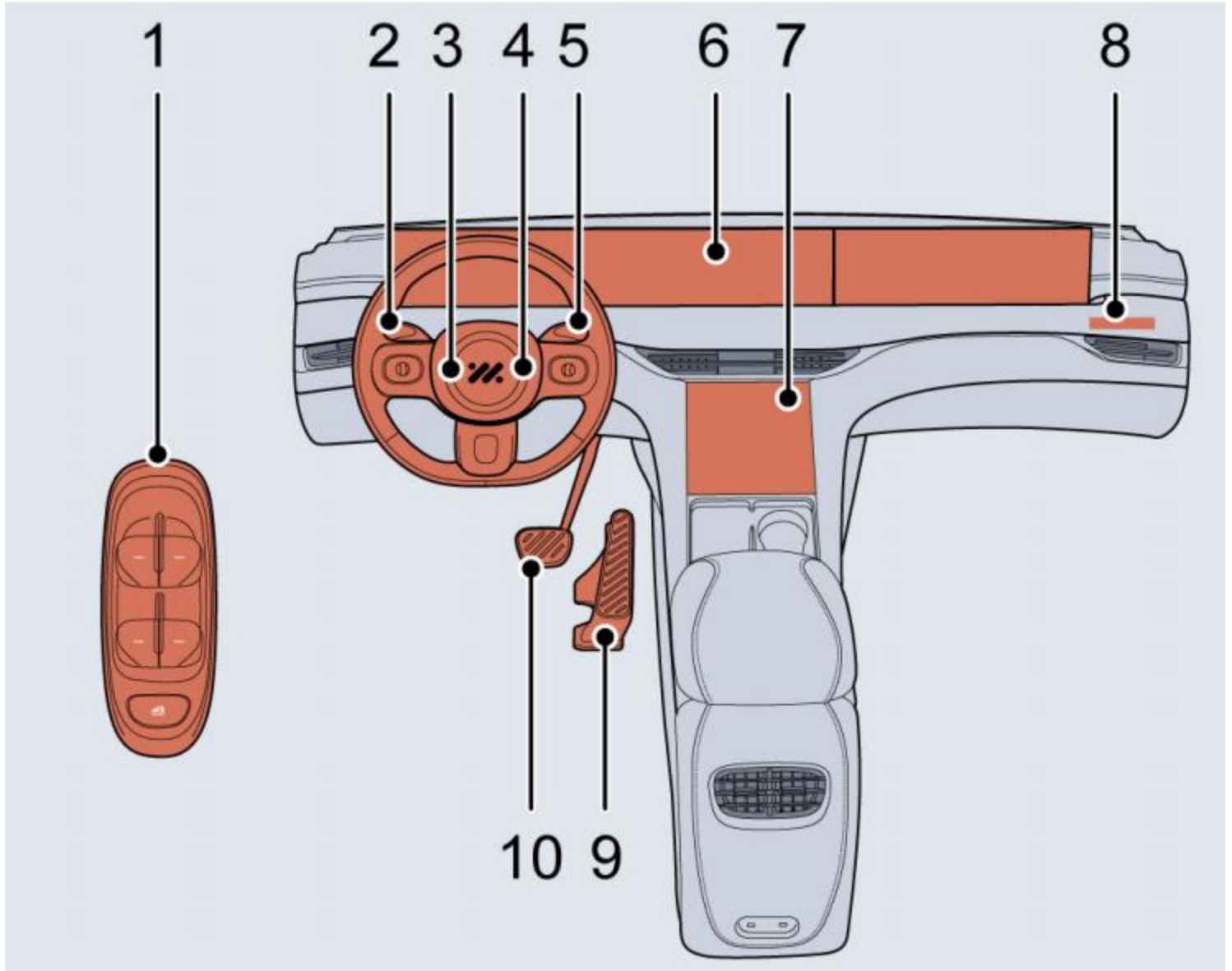











1. Front combination lamp
2. Exterior rearview mirror
3. Outer door handle
4. Charging port
5. Front towing part
6. High-mounted stop lamp
7. Reverse lamp
8. Rear combination lamp
9. Rear fog lamp

Interior Introduction



1. Power operated window switch
2. Light and wiper lever switch
3. Horn button
4. Driver airbag
5. Gear shift lever switch
6. Driver screen
7. Central screen
8. Front passenger airbag
9. Accelerator pedal
10. Brake pedal

Switch Identification

Switch Identification	Name	Switch Identification	Name
	High beam		Turn signal lamp
	Low beam		Fast speed wipe
	Single wipe of front wiper		Low speed wipe
	Front wiper wash		Wipe off
	Hazard warning lamp		Automatic wipe
	Door lock switch		Door unlock switch
	Door open switch		Rear window disabled
	Window control		A/C switch

Starting the Power System

Engine Immobilisation

The engine immobilisation is designed to safeguard the vehicle from theft. The vehicle cannot be started until the immobiliser is deactivated.

If the immobiliser has been activated, before it is turned off, the horn will sound continuously. If NFC is used for unlocking, the anti-theft alarm will be deactivated.

If the instrument displays “Please Put the NFC Key in Interior Sensing Area” or the anti-theft system warning lamp is on, please put the NFC key in interior sensing area. If the vehicle is still unable to start, please contact an Authorised Repairer.

Locking and Unlocking from Outside

When the vehicle is locked, the turn signal lamps illuminate three times; when it is unlocked, the turn signal lamps illuminate once.

Door Lock System (NFC)

NFC Card Keys

Lock: With the vehicle unlocked, after you leave the driver position, and close all doors, bonnet and tailgate, when you carry a valid NFC card to touch the NFC card swiping area on pillar B exterior trim panel on the driver side and keep for several seconds, the vehicle will be locked.

Unlock: With the vehicle in a full anti-theft state, when you carry a valid NFC card to touch the NFC card swiping area on pillar B exterior trim panel on the driver side and keep for several seconds, the vehicle will be unlocked.



Note: When the vehicle is locked, use the NFC card to unlock; if no other operations are done within a period of time, the vehicle will automatically lock.

Note: After the vehicle is unlocked with NFC card, if the maximum valid time to start the vehicle is exceeded, the vehicle cannot be started, in which case, please put the NFC card on the NFC sensing area in the centre console.

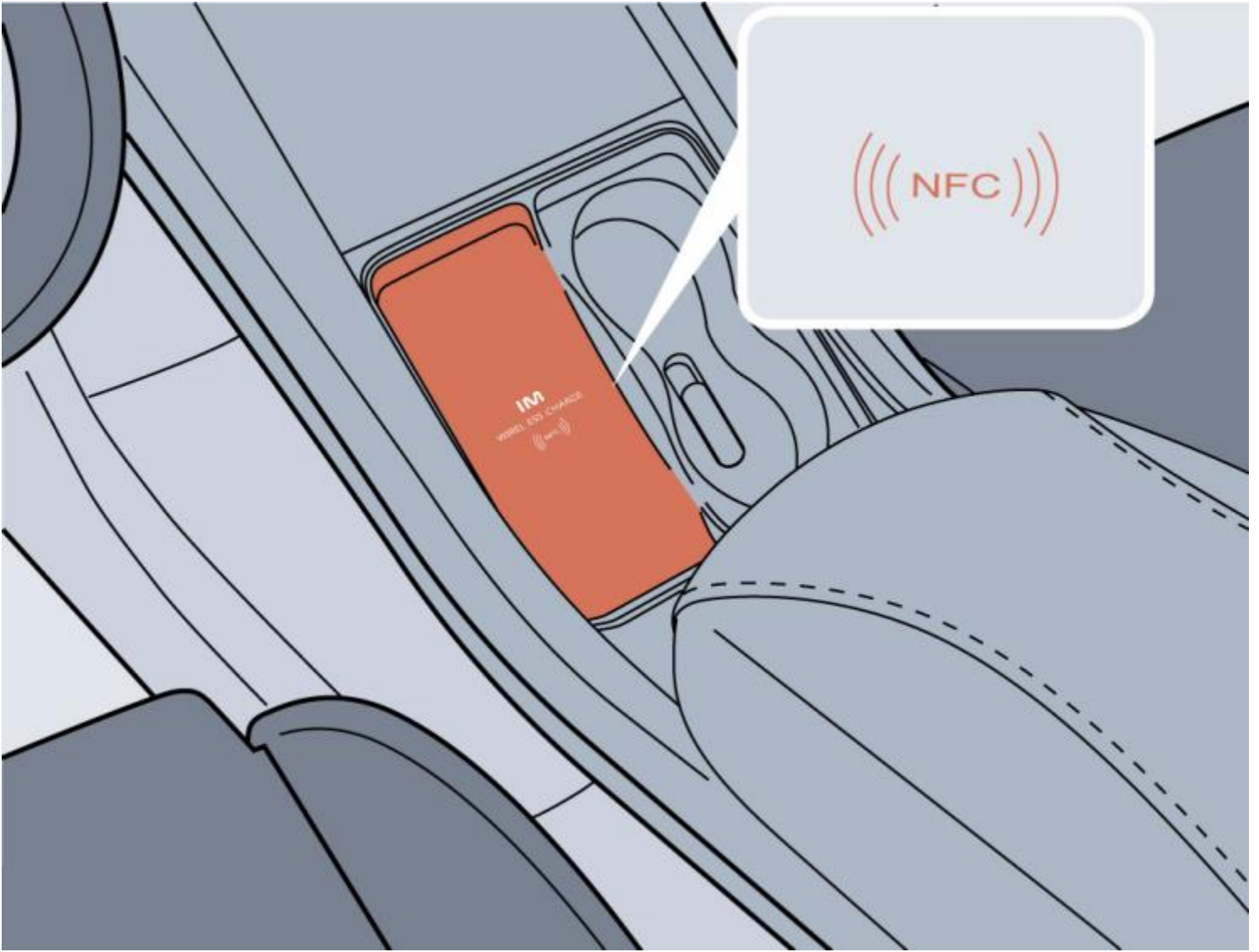

Note: If NFC entry/start module fails, please contact an Authorised Repairer for service.

Anti-theft System Reminder

If locking operation is performed when the driver's door is not fully closed, the vehicle will not be locked, and the horn will sound once to indicate a mislock. In this case, the body anti-theft system is inoperative.

If locking operation is performed when the driver's door is closed but the passenger's door, bonnet or tailgate is not fully closed, the vehicle horn will sound once, indicating a mislock. In this case, the body anti-theft system will be partially enabled (all fully closed doors, bonnet or tailgate will be protected, but an open aperture will not!). As soon as the open door, bonnet or tailgate is closed, the system will automatically revert to an armed state.

Interior Lock

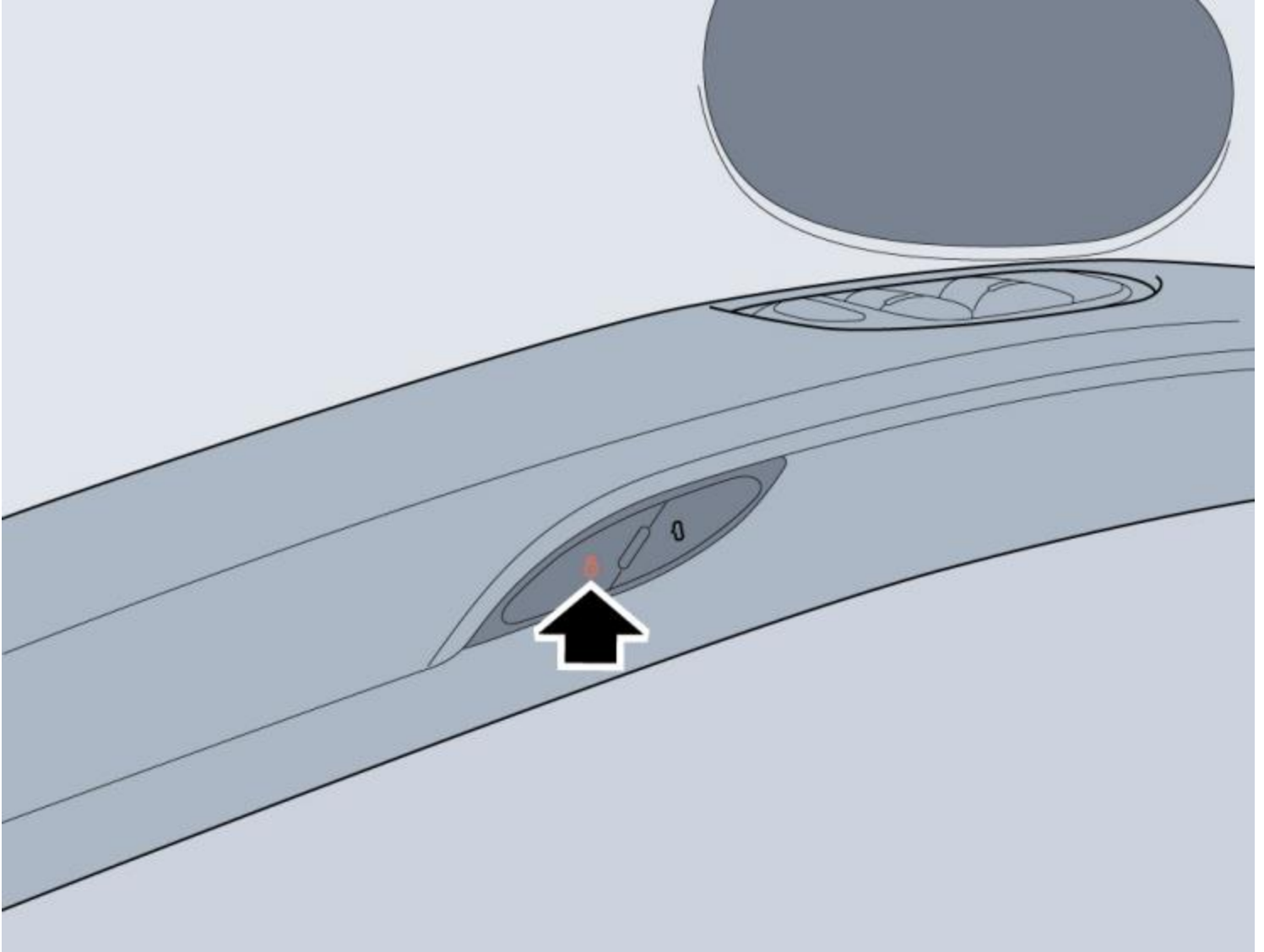

- Door lock

When the anti-theft system is inoperative, short press the interior lock switch after closing doors to lock all doors, and the yellow indicator for locking illuminates. If the non-driver's door, bonnet or tailgate is not closed, short press the interior lock switch, the yellow indicator for locking on the switch flashes.

- Door unlock

When the yellow indicator for locking illuminates, short press the interior lock switch to lock all doors, and the yellow indicator for locking goes out.

Note: If the anti-theft system is switched on, pressing the interior button switch will not lock/unlock the doors while triggering the anti-theft system.

Manual Door Open

When the vehicle is unlocked, pulling the outer door handle can open the door.

When you enter the vehicle and close the door, press the graphic button on the inside of the door to open the door.

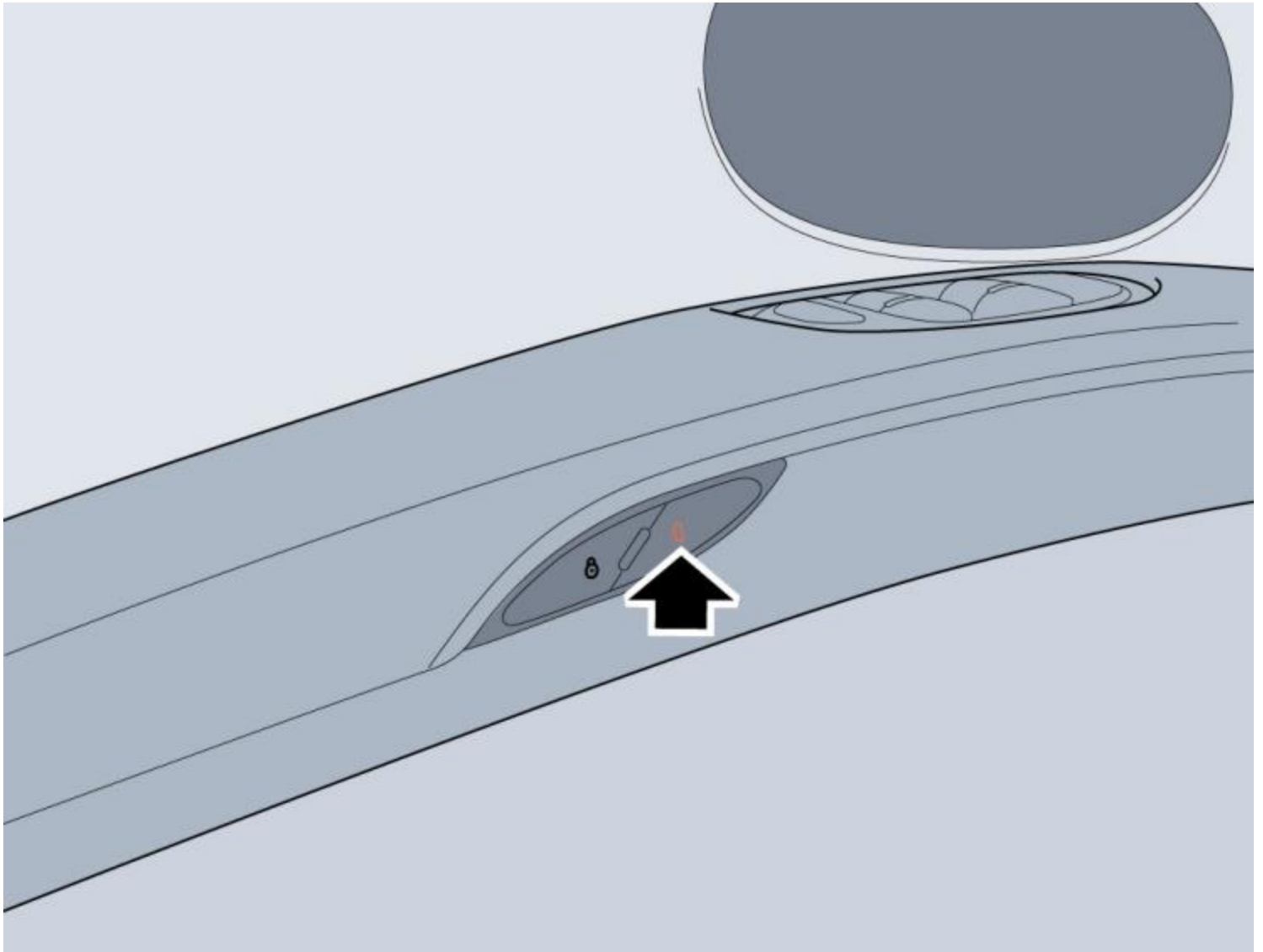

Note: When the door cannot be opened by pressing the door button or cannot be opened in other cases, you can pull the inner emergency handle to open the door, and contact the Authorised Repairer as soon as possible.

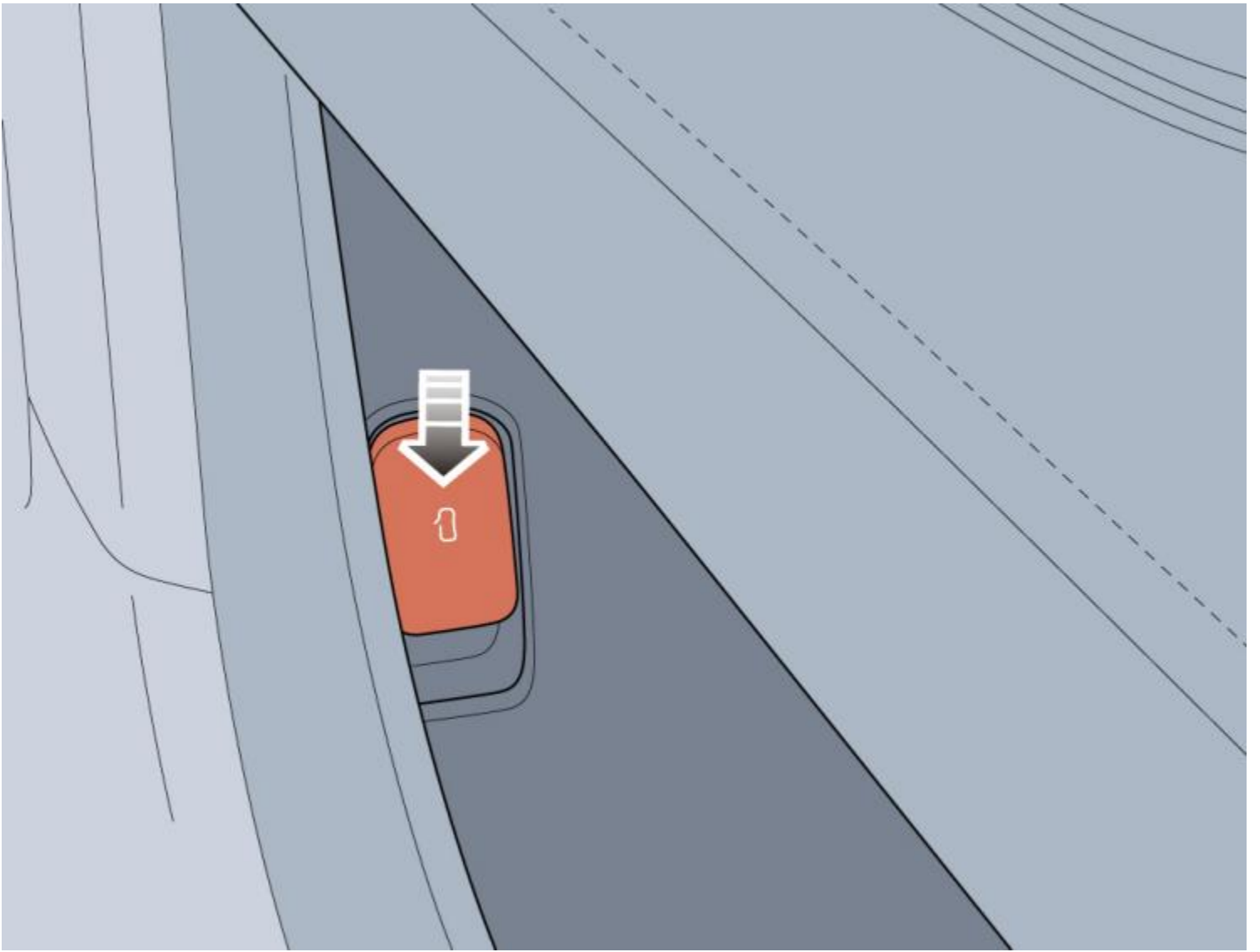

Auto Lock When Driving

All the doors will be locked automatically when the running speed exceeds a certain speed per hour.

Child Lock

Warning: NEVER leave children unsupervised in the car.

Enable or disable the child lock as follows:

In the Operation interface on the central screen, open “Lock - Child Lock - Effective Range” page, and select to enable or disable the child lock on the corresponding side.

With the child lock enabled, the rear door on the affected side cannot be opened from inside the vehicle, but can be opened from the outside.

Controls

Light

Lock

Adjustment

Driving

ADAS

Connection

Sound

Display

General



Ventilation



Off



On

Close Windows After Locking

Please ensure safety before locking the car



Child lock

Rear Left

Rear Right

Full Rear Row

Child Lock

Effective range can't adjust



Tailgate

Low

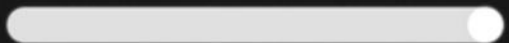

High



25°



Powering On/Off the Vehicle

Starting the Power System

When you open the driver's door with valid key, and sit in the driver seat, the instrument panel and touch screen are powered on. The central screen displays the door state and state of charge, and all electric appliances are ready for operation.

Check that the doors are fully closed before driving, and then:

- Depress the brake, and make the vehicle enter Ready state;
- Select Drive gear (or shift to Reverse gear for reversing);
- Release the brake.

Turning off the Power System

In case of an emergency, the power system can be turned off as follows when normal pullover is allowed:

1. After the vehicle is stopped, press the P gear, the red indicator lamp on the driver instrument screen is always on and the electronic parking brake is enabled.

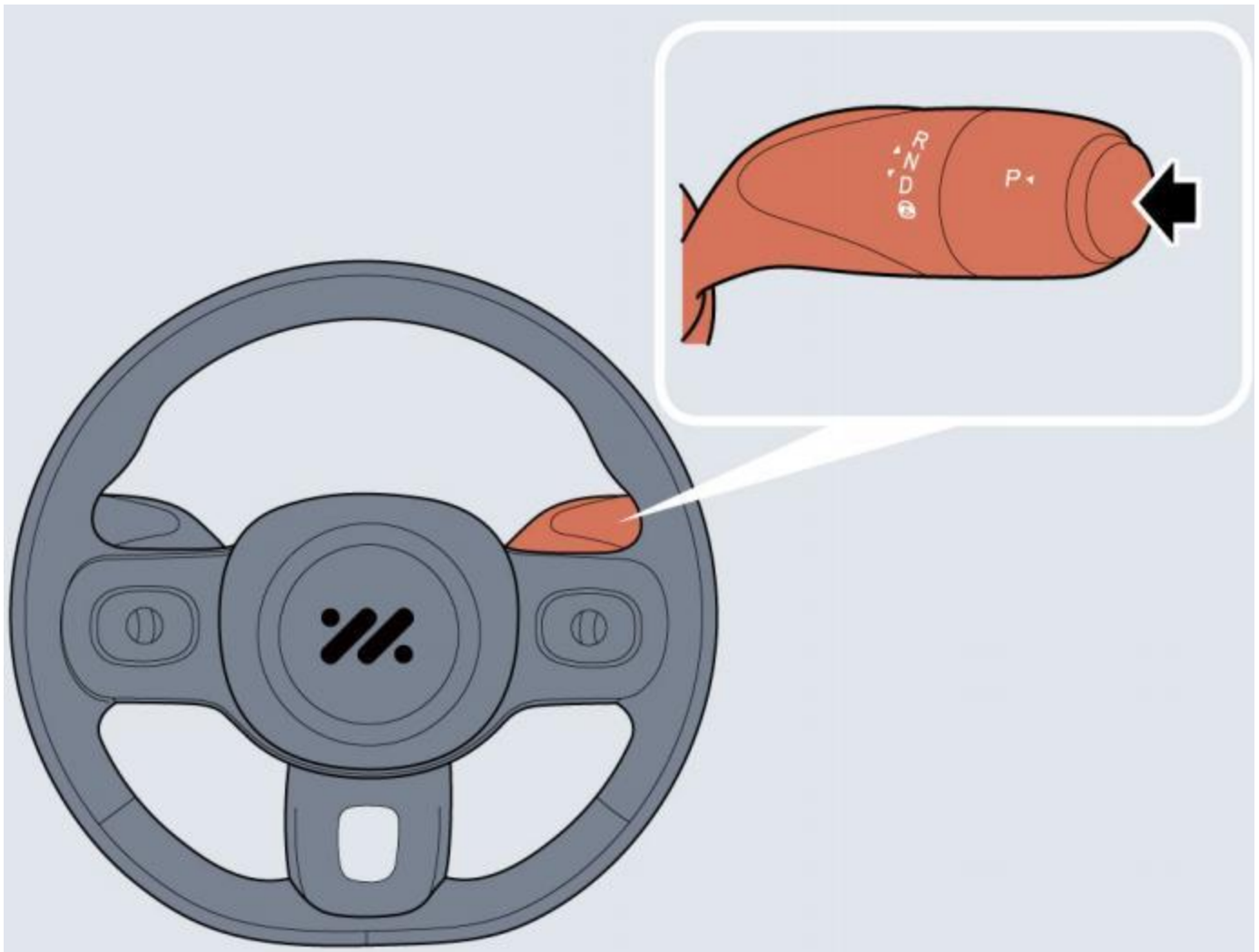

2. Tap "Settings - General - Vehicle Power Supply- Turn off Vehicle Power Supply" or attach the NFC card to pillar B to turn off the vehicle power supply.

Standby Starting Procedure

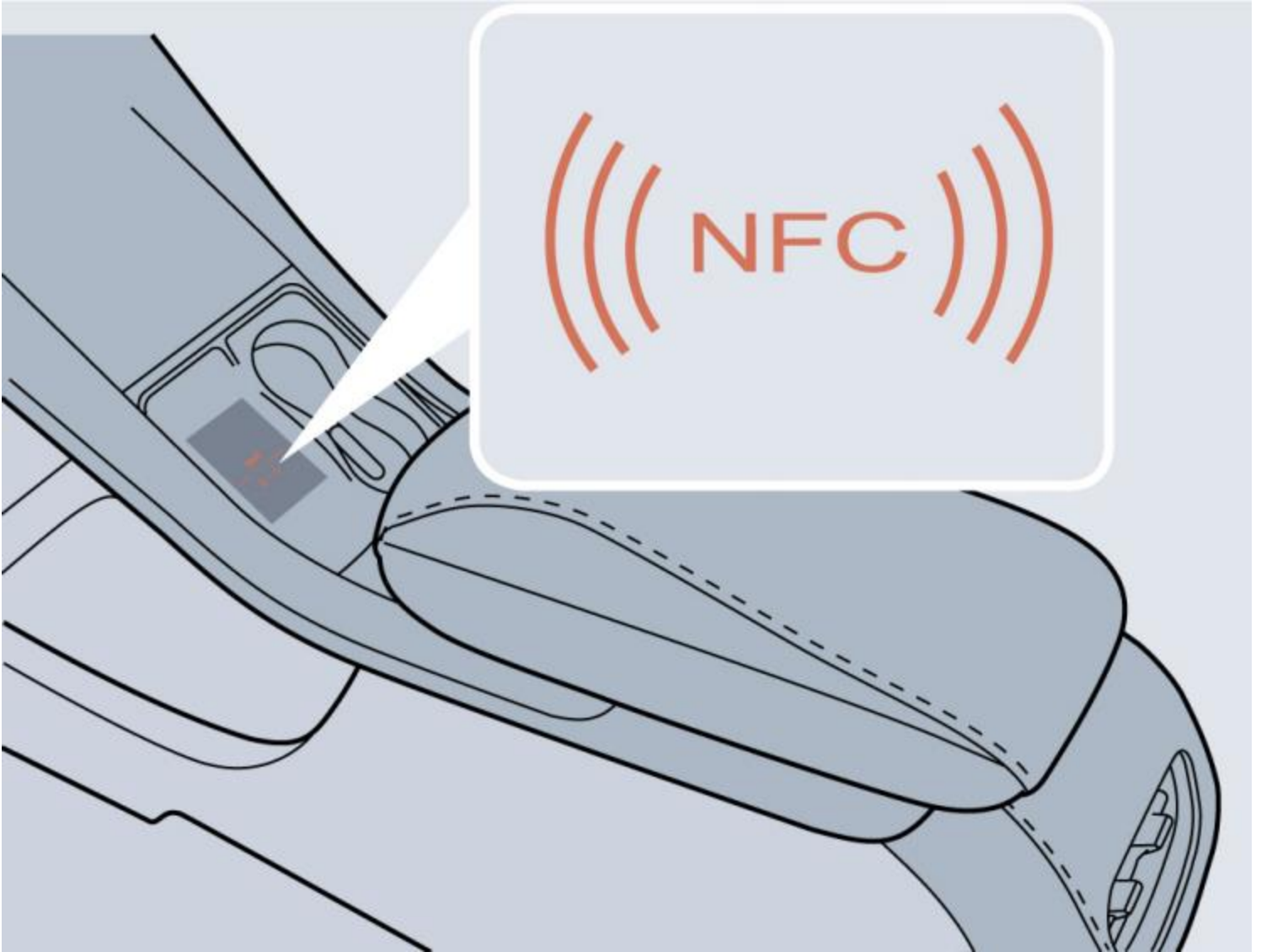

When the vehicle is in a strong radio signal interference area, please start the vehicle by the standby starting procedure according to the following steps:

1. Place the NFC key in the position and at the angle as illustrated.
2. Depress the brake, and start the power system.

After the vehicle leaves the interference area, if the keyless starting procedure can still not be used normally, please seek an Authorised Repairer.

Exterior Light

Exterior Light Control Interface

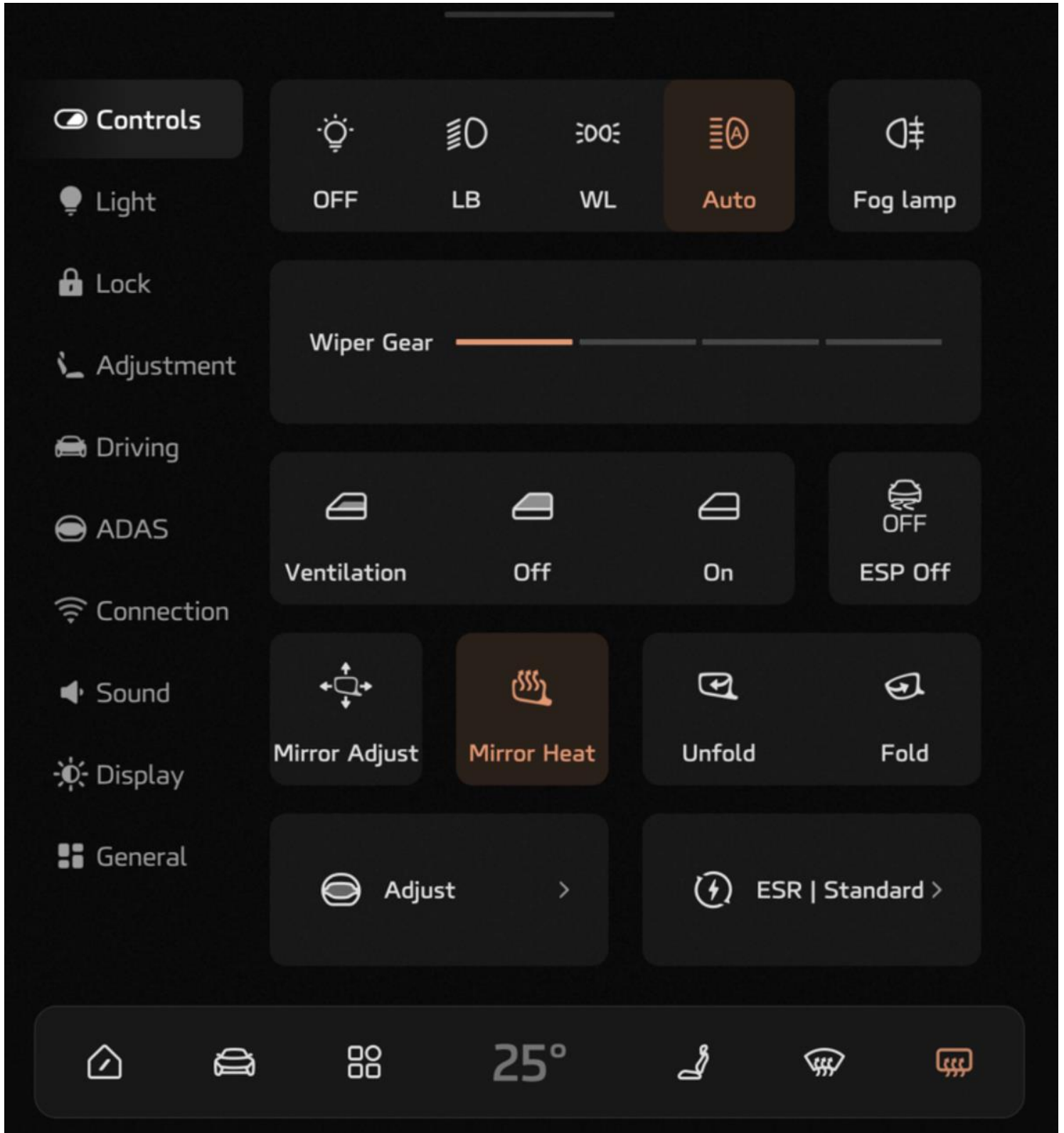

Enter the “Light Control” interface through “Settings - Controls” on the central screen, and control the exterior light.

Exterior Light Control

- AUTO Lamp

After the vehicle is powered on, when you touch the headlamp “AUTO” position, the icon illuminates, and the AUTO lighting system will automatically switch the position lamps, switch backlights and low beam headlamps on and off according to the intensity of current ambient light.

- Position Lamp

When you touch the “Position Lamp”, the icon illuminates, and the daytime running lamps, rear position lamps and switch backlights light up.

When the driver powers off the vehicle on the centre display, and leaves the vehicle by opening the door, if the position lamps stay on, an audible alarm will emit.

- Headlamp

When you touch the “Low Beam”, the icon illuminates, and the low beam headlamps, width lights and switch backlights light up.

- Exterior Lights OFF

When you touch “OFF”, the icon illuminates, and the exterior lights are off.

- Rear Fog Lamp

With headlamps on, when you touch the “Rear Fog Lamp”, the icon illuminates, and the rear fog lamps light up. With rear fog lamps on, the indicator on the instrument panel illuminates.

- Daytime Running Lamp

When the vehicle is powered on, the daytime running lamps illuminate automatically. When the low beams are on, the daytime running lamps extinguish automatically.

- Welcome Light

When the vehicle is unlocked, the system will automatically turn on the low beams and width lights to show the welcome effects. The welcome light can be set in the "Vehicle Settings" interface on the central screen.

Switching between High Beam and Low Beam

Manual switching

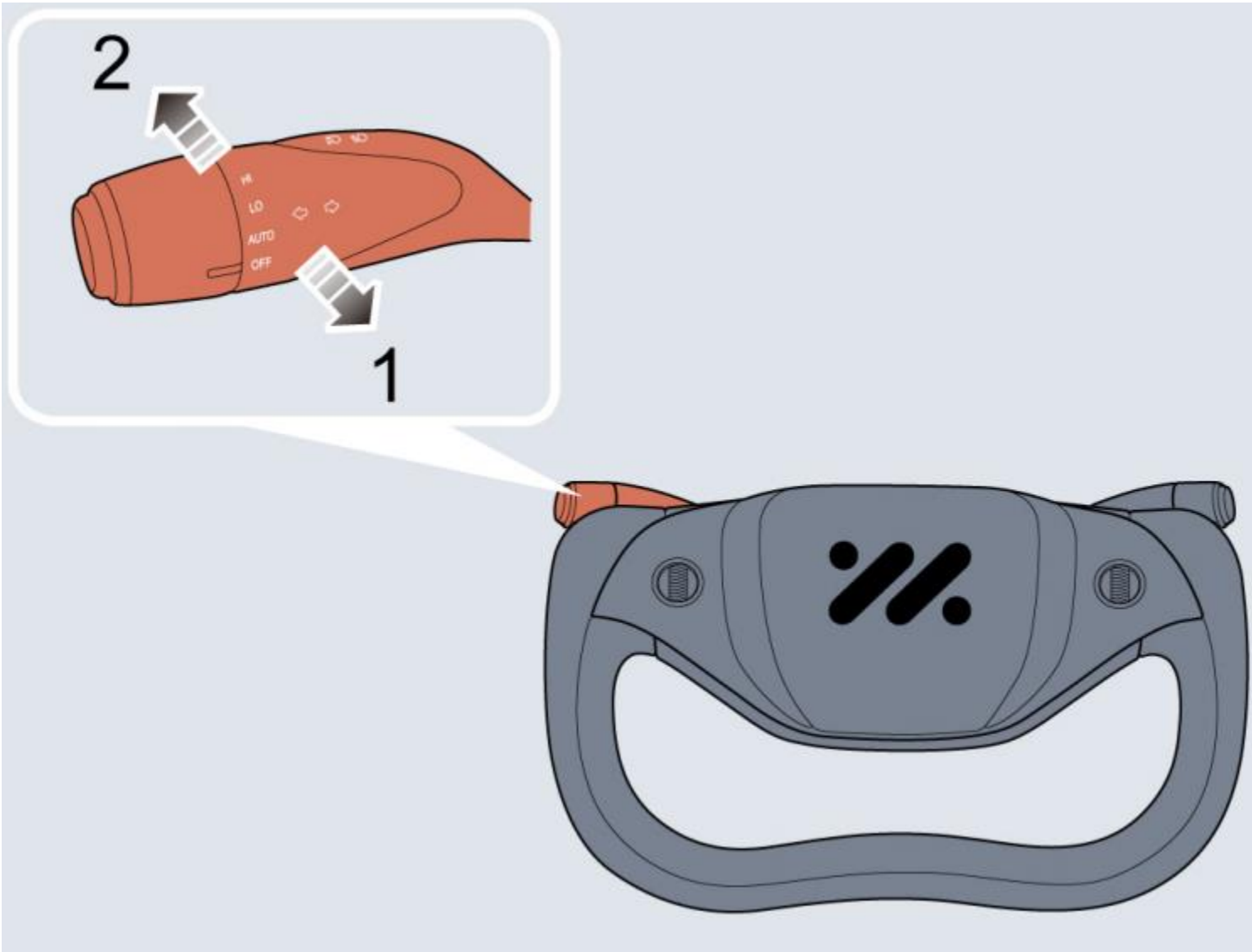

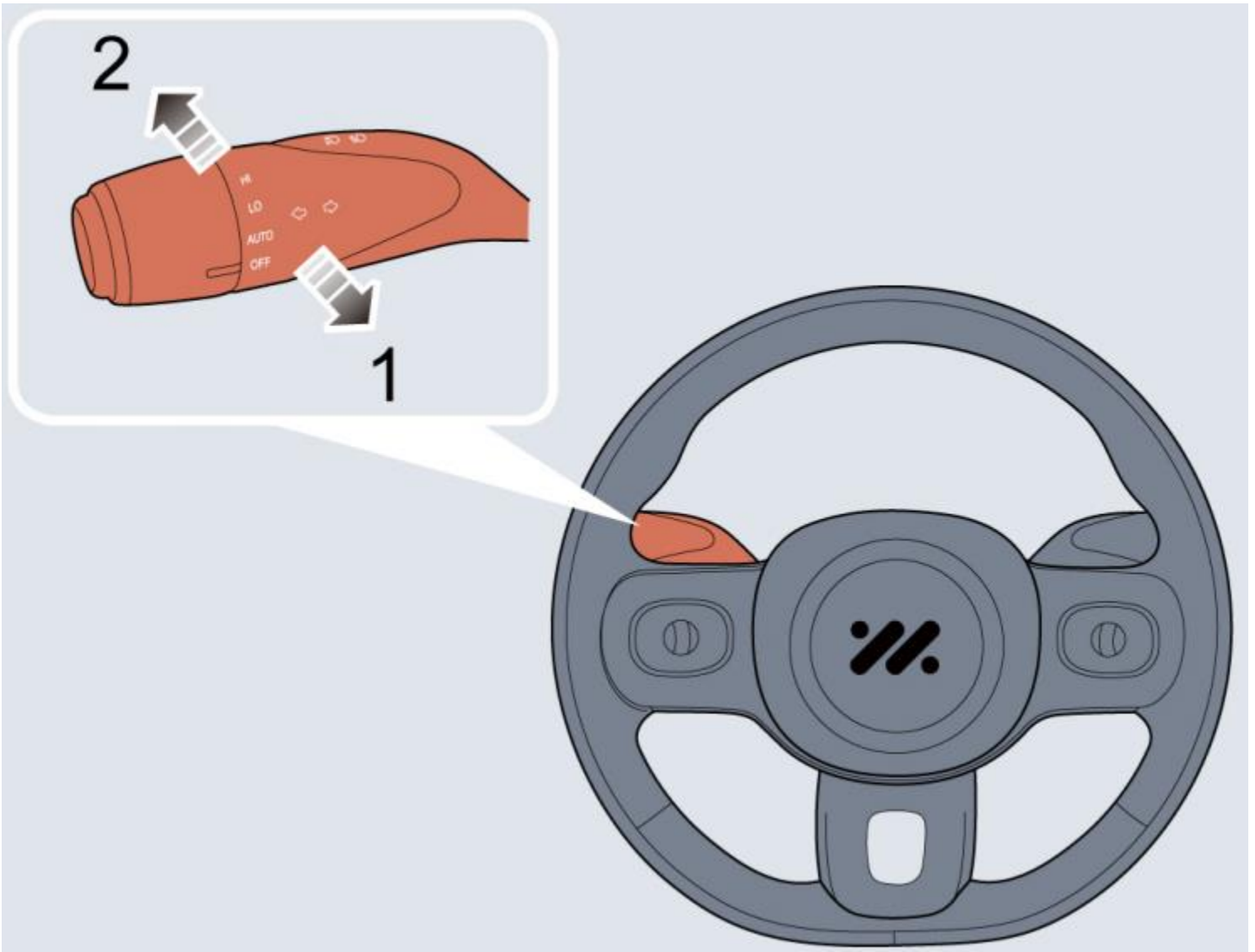

Manual switching

With the low beams illuminated, push the lever (2) towards the driver instrument screen to turn on high beams. The indicator of high beams on the driver instrument screen illuminates.

Push or pull the lever (2 or 1) once again to switch to low beams. Repeatedly pull the lever to make the high beams flash.

Warning: When switching between the high beam and low beam headlamps, please pay attention to not dazzling the driver of oncoming vehicles.

Turn signal lamp

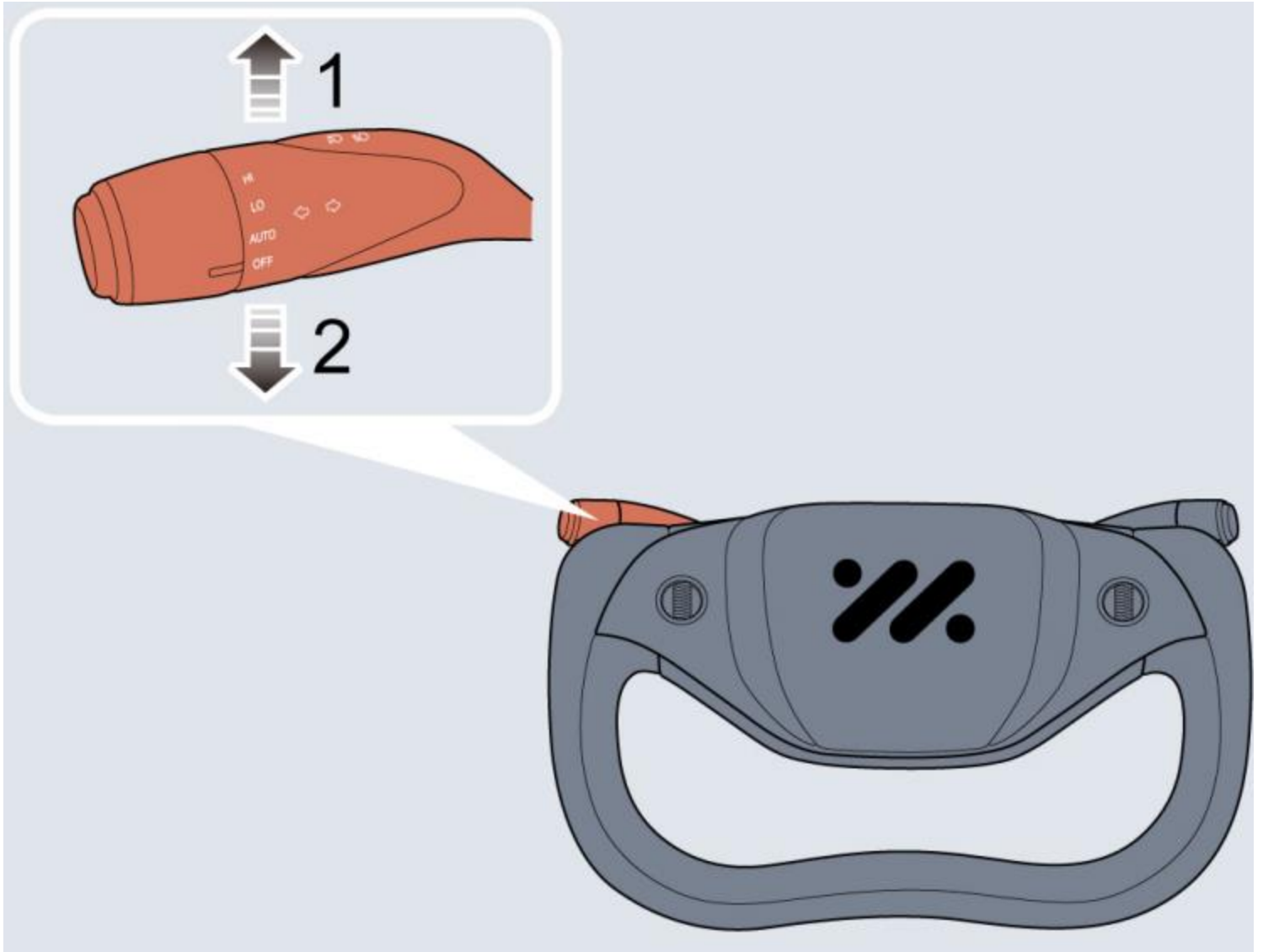

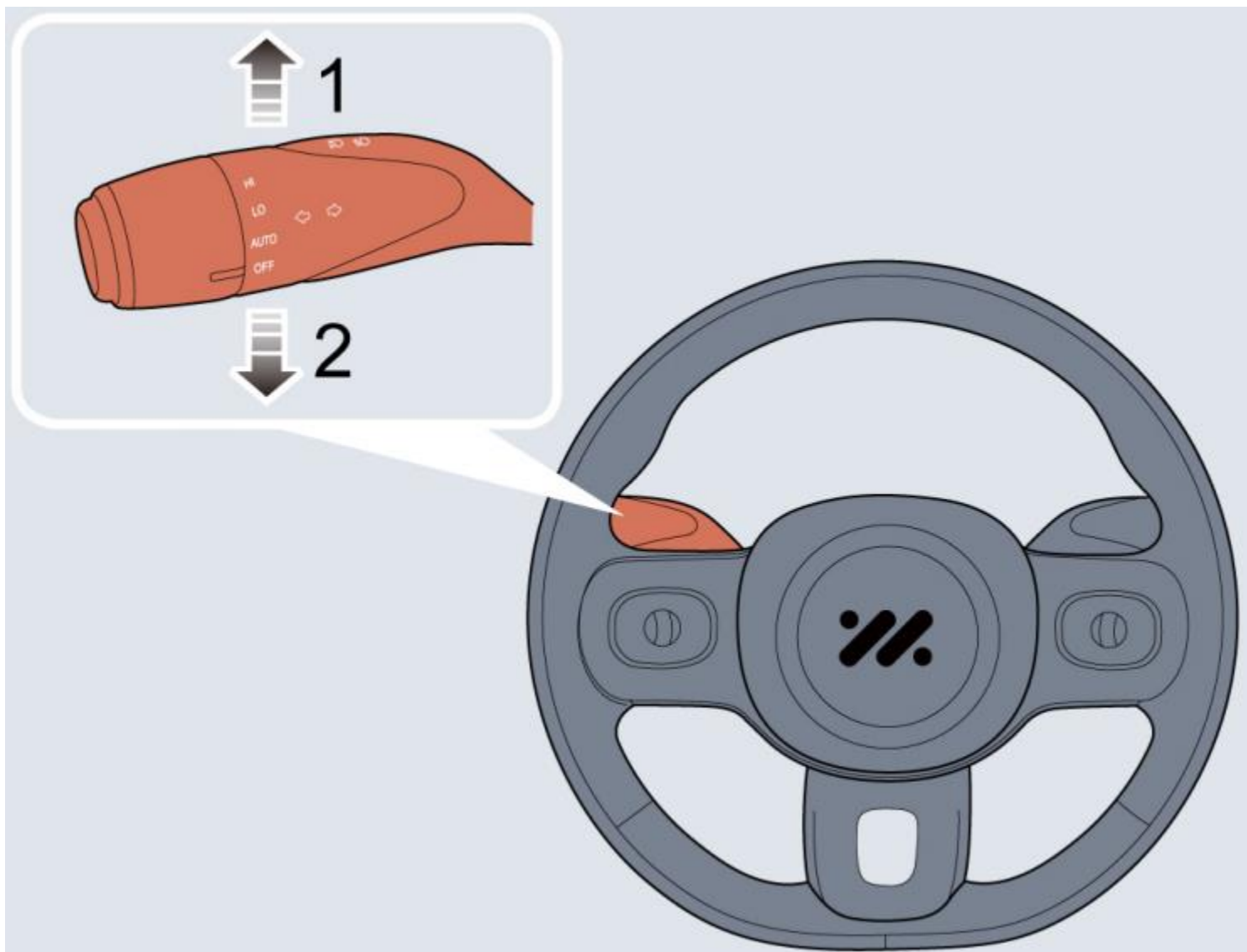

When the vehicle is powered on:

- Move the lever (2) down to turn on the left turn signal lamp;
- Move the lever (1) up to turn on the right turn signal lamp.

The corresponding direction indicator lamp in the instrument will flash when the turn signal lamps are working.

After resetting the steering wheel, the lever will be automatically reset, and the turn signal lamps go off. But if the steering wheel angle is small, manually reset the lever to turn off the turn signal lamps. If the lever angle is small, it will be reset immediately. And the turn signal lamps and direction indicator lamps flash for several times and then automatically go off.

BSD note: When the customer turns on the left turn signal lamp, and the speed is lower than 20Km/h, the road conditions in the front left blind spot vision are displayed on the driver instrument screen; when the speed is higher than 20Km/h, the road conditions in the rear left blind spot vision are displayed on the driver instrument screen. When the customer turns on the right turn signal lamp, the road conditions in the rear blind spot vision are displayed on the driver instrument screen; the BSD will be disabled in half screen mode, and exited when the turn signal lamp is turned off.

Hazard warning lamp

The Hazard Warning Lamp button  is located on the overhead console. Short press this button to turn on the hazard warning lamp. All the turn signal lamps and direction indicator lamps will flash together. Press the button again to switch off the hazard warning lamp, and the lamp stops flashing.

Light Levelling

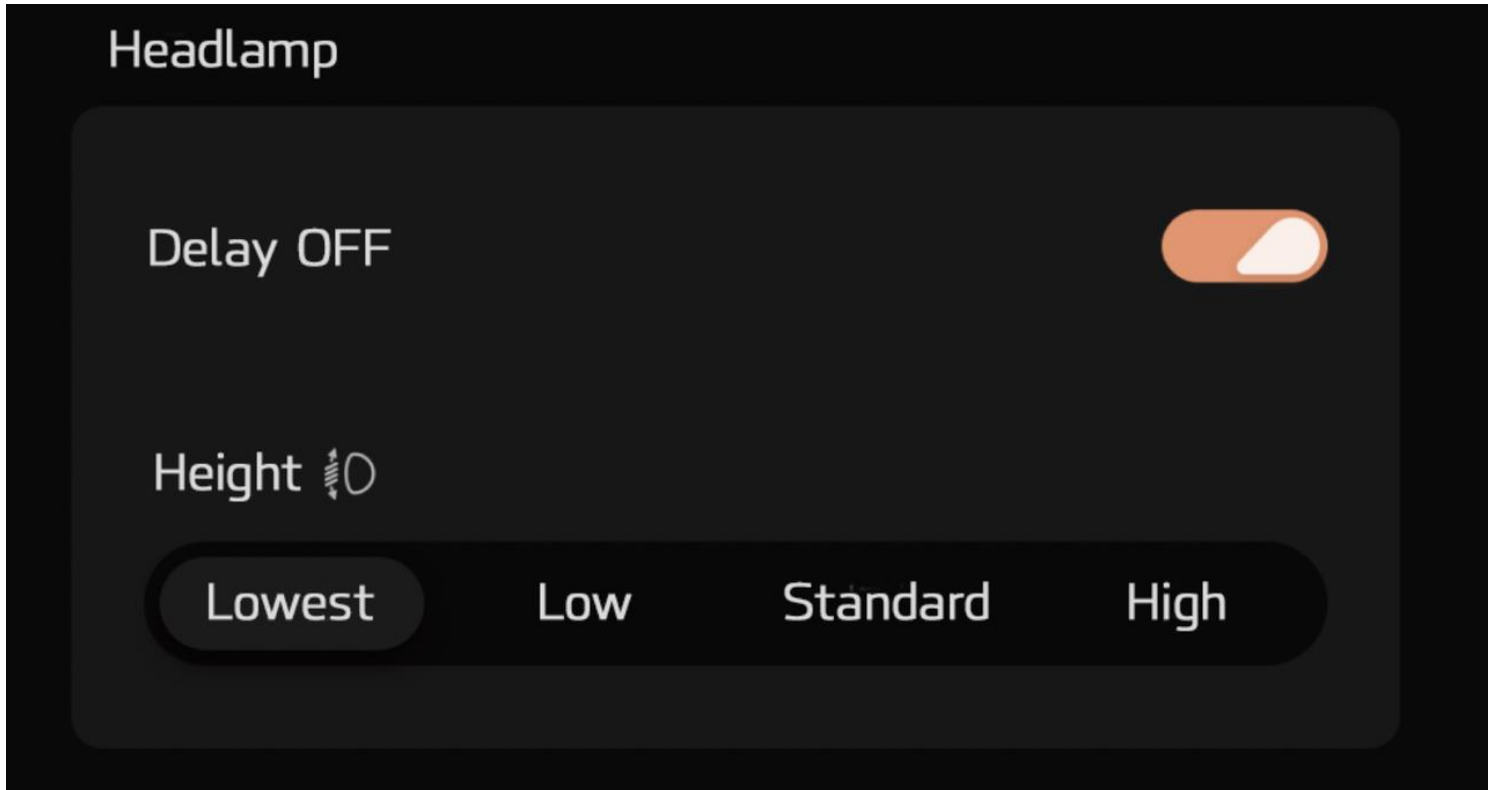

The headlamp levelling can be adjusted as per the following table according to the vehicle load.

Location	Load
Minimum	Driver only, plus an evenly distributed load in the trunk.
Low	All the seats occupied plus an evenly distributed load in the trunk.
Standard	All the seats occupied with no load in the trunk.
High	Driver only, or driver & front passenger.

Headlamp Delay OFF

When it is in AUTO position for lighting control, the low beams and width lights will illuminate for a period of time after the vehicle is locked. The headlamp delay off function can be enabled and disabled through the “Settings” - “Light” path on the central screen.

Interior Light

Interior Light Control Interface

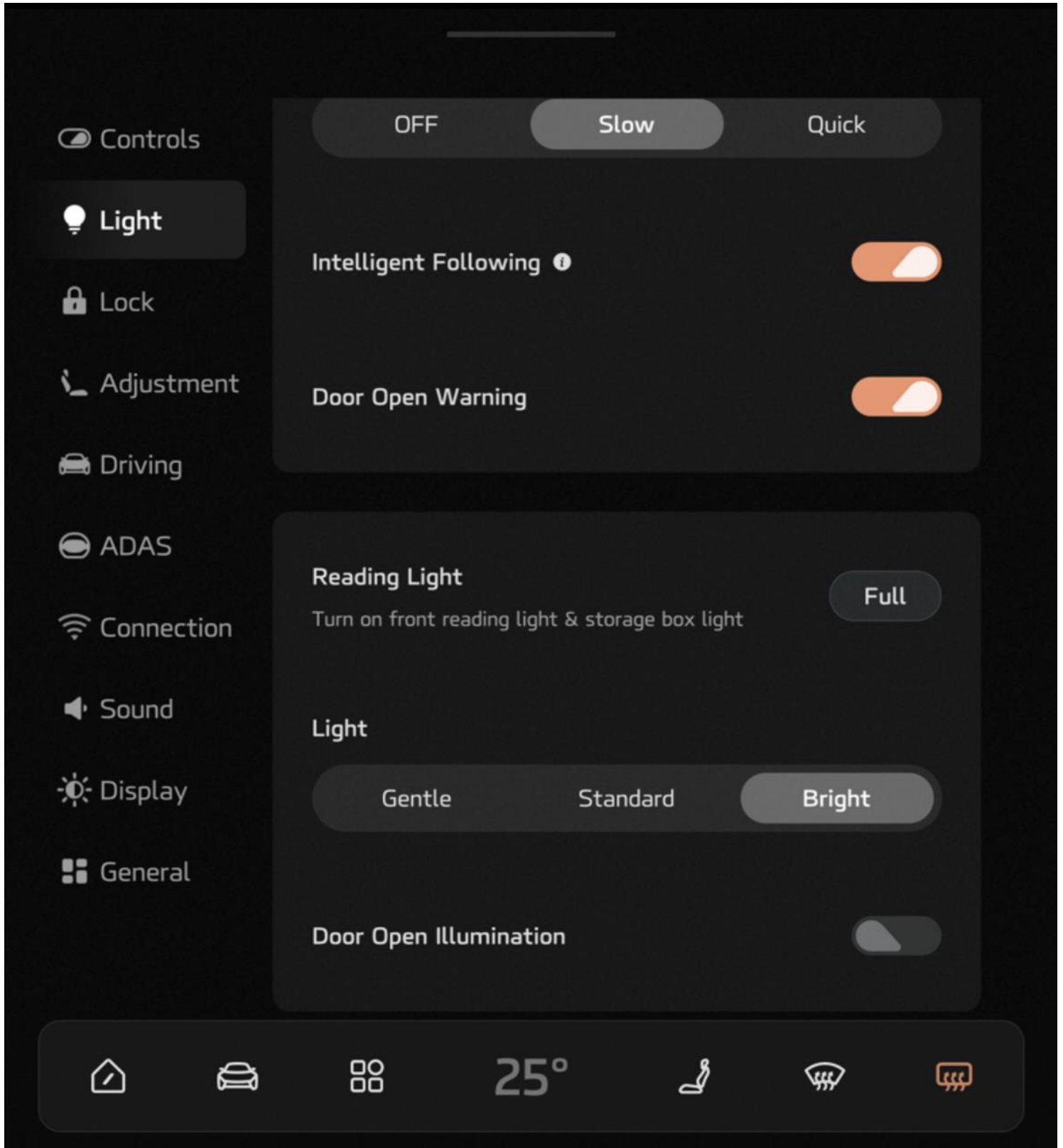

Through the "Settings" - "Light" path on the central screen, you can enter the Interior Light Control interface, operate and set the reading light, centre console light and ambient light.

Reading Light

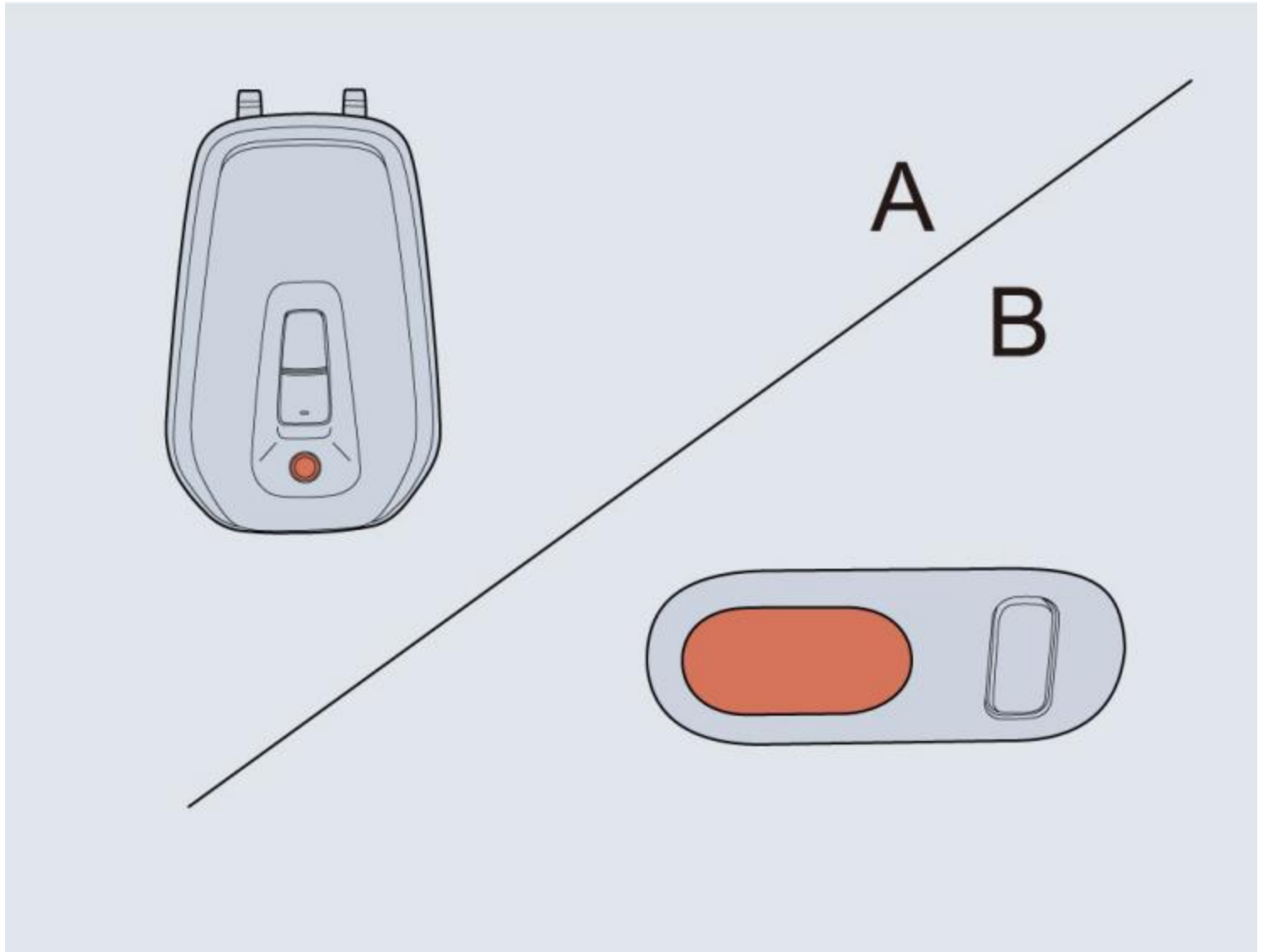

Front reading light (A) is located on the overhead console above the windscreen. Rear reading lights (B) are located on both sides of the ceiling.

Touch switch control

Briefly touch the touch switch on either side of the front reading light, as shown in the figure, to turn on the front reading light on the corresponding side. Briefly touch the touch switch again to turn off the front reading light on the corresponding side.

Briefly touch the touch switch on the rear reading light, as shown in the figure, to turn on the corresponding light. Briefly touch the touch switch again to turn off the light.

Central screen control

All on/off

Click the "All On" button of the reading light in the Interior Light Control interface of the central screen, and all the front and rear reading lights will be turned on. Click the button again, and all the front and rear reading lights will be turned off.

Brightness adjustment

The brightness settings of reading light includes Soft, Standard and Bright. Click the reading light brightness level in the Interior Light Control interface of the central screen to adjust the brightness of the reading light.

Automatic control

Click the "Door Open Illumination" button in the Interior Light Control interface of the central screen to enable or disable the automatic control function. With the function enabled, when any door is opened, the front and rear interior lights will come on automatically.

Note: Under normal circumstances, if the doors open longer than a certain time, the front and rear reading lights will extinguish automatically.

Note: When the vehicle is locked, the reading light will be turned off.

Centre Console Light

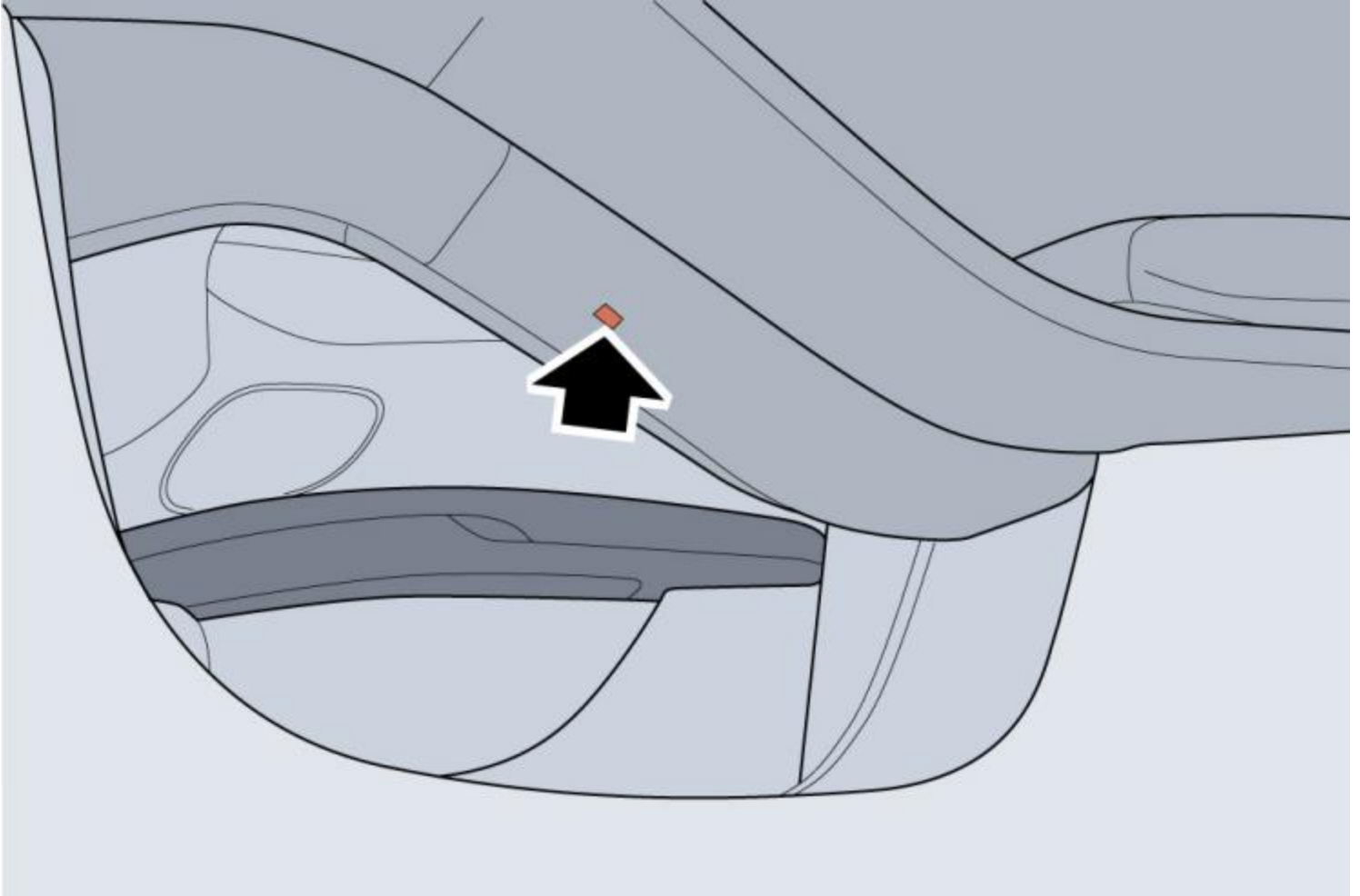

The centre console light is located on the back of the central screen, illuminating the front storage box area of the centre console.

Touch switch control

Briefly touch the touch switch on either side of the front reading light to turn on the centre console light. Briefly touch the touch switch again to turn off the centre console light.

Central screen control

Click the "All On" button of the reading light in the Light Control interface of the centre screen, and the centre console light will be turned on. Click the button again, and the centre console light will be turned off.

Ambient Light

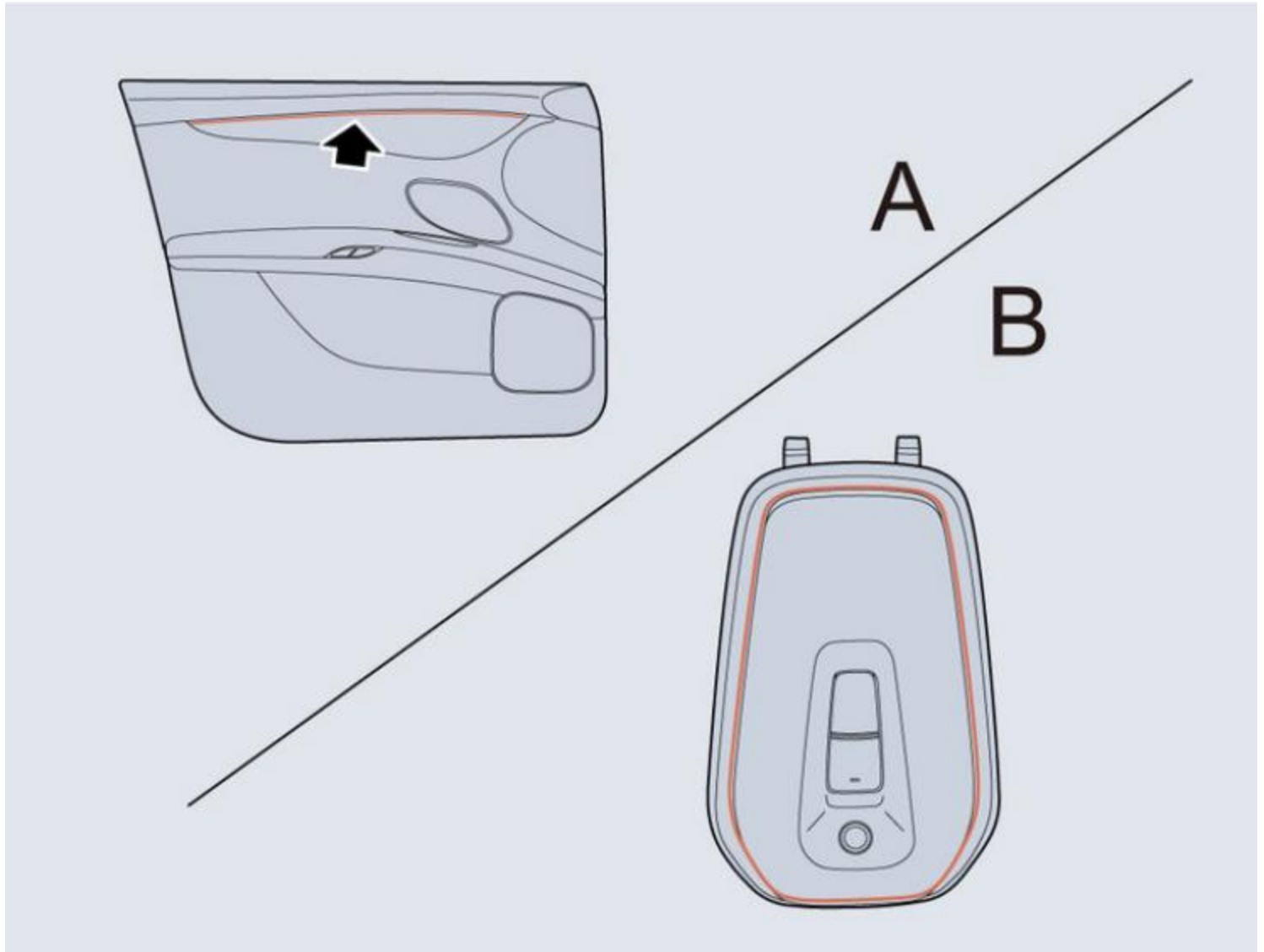

Ambient light is a kind of decorative lamp, which is equipped to create a comfortable atmosphere inside the vehicle. Colored ambient lights are provided on the upper part of front/rear door interior trim panel (A) and front reading light (B). The method of illuminating the ambient light can be set on the central screen.

Turning On/Off

Turn on the master switch of the ambient light on the central screen to turn on the ambient light, adjust the color and brightness and select the mode.

Color selection

You can choose the theme color directly according to your personal preference or click the color palette to change the color of the ambient light. The last memorized color will be set by default after each restart of the vehicle.

Brightness adjustment

The brightness of ambient light can be adjusted by dragging the brightness bar, and will be stored and memorized. The last memorized brightness will be set by default after each restart of the vehicle.

Intelligent following

After the Intelligent Following button is pressed, the ambient light will enable the music rhythm, driving mode switch reminder and other functions.

Door open risk warning

With the switch on, when the vehicle stops and the door is open, if a vehicle approaching behind the door is detected, the ambient light on the door trim panel will turn red and flash for reminder assistance.

Wipe and Wash

Windscreen Wiper

When the vehicle is powered on, operate the lever to select different wipe modes.

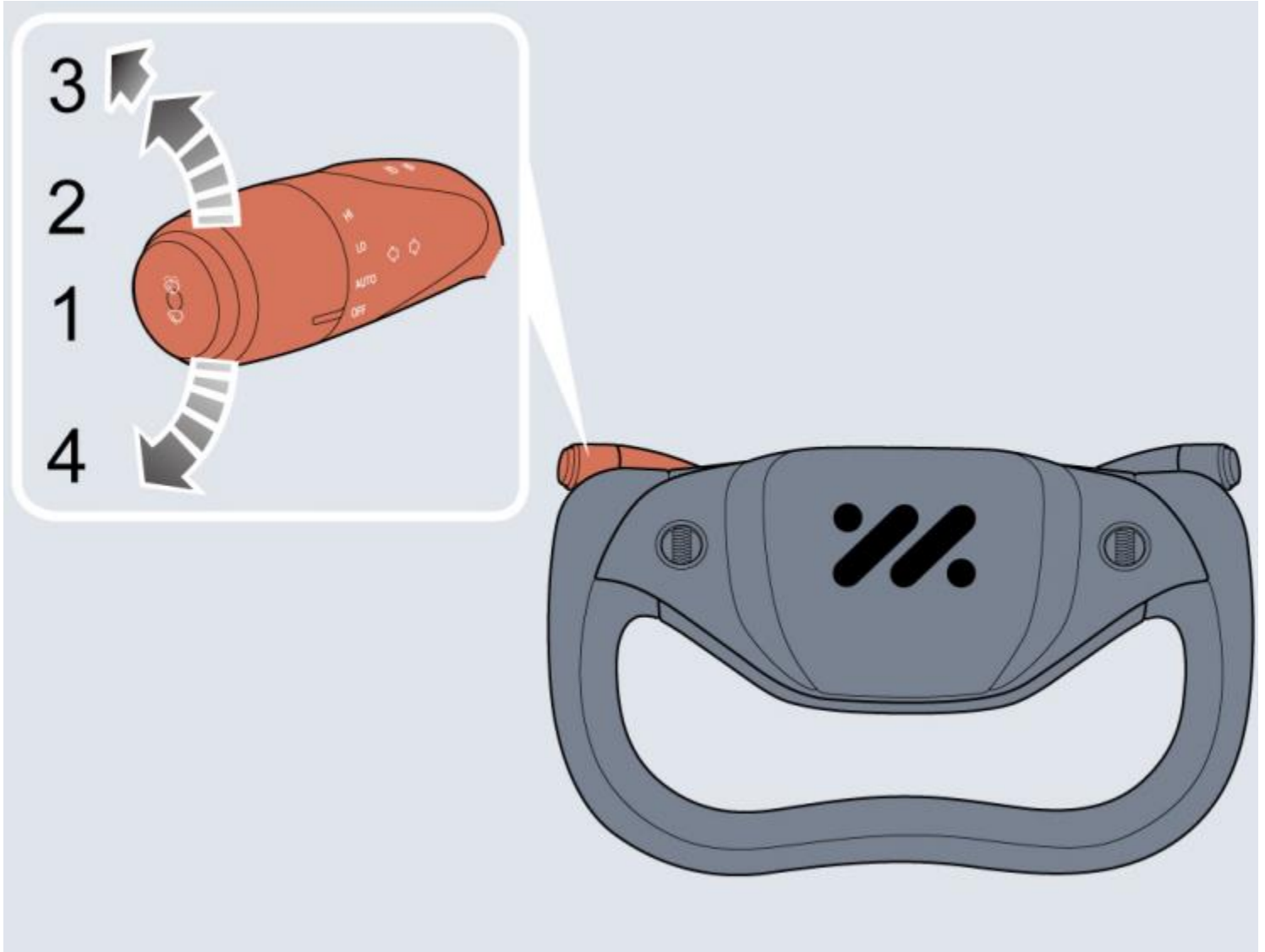

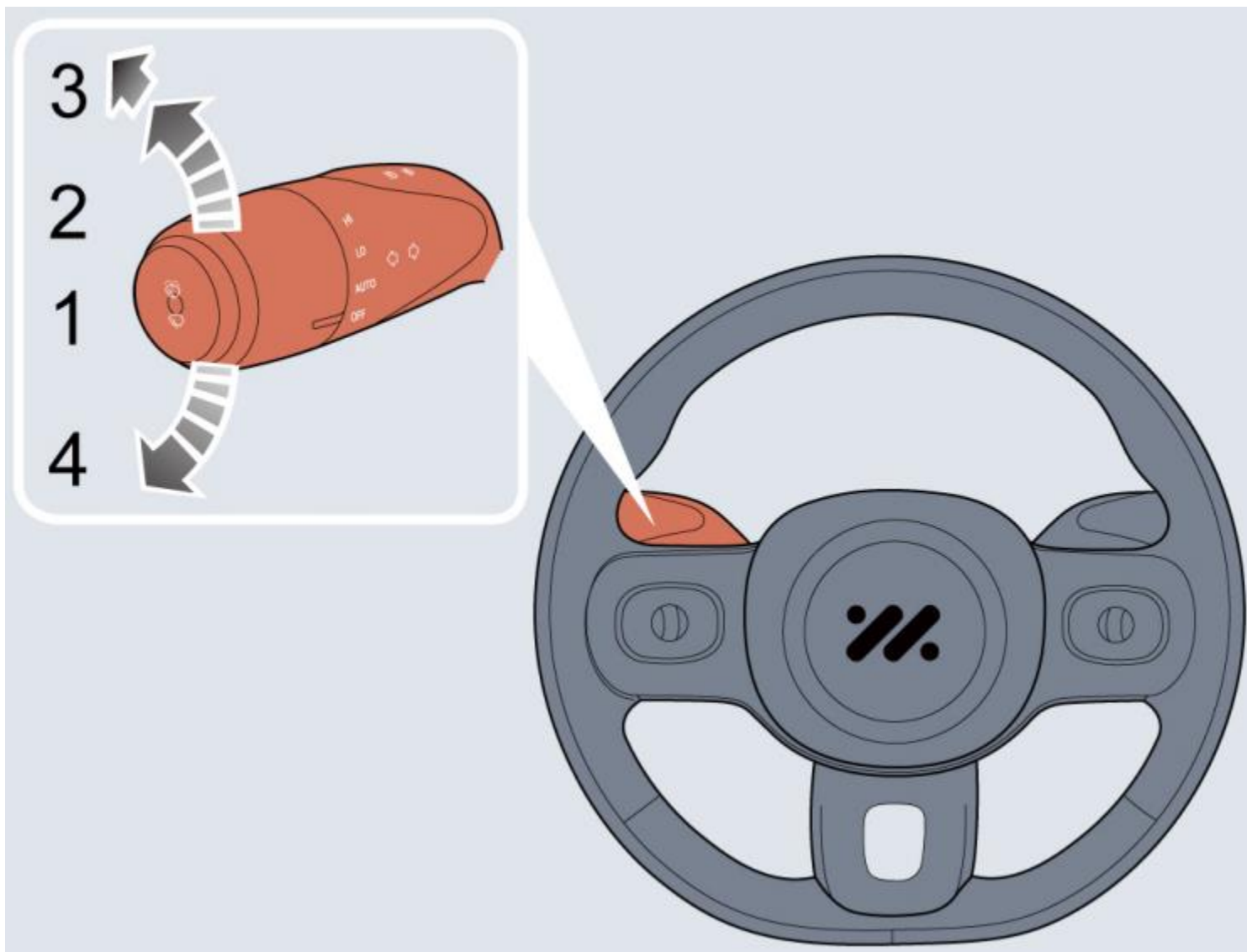

Indication of displayed position

- **AUTO**: Automatic wipe
- **LO**: Slow speed wipe
- **HI**: Fast speed wipe
- **OFF**: Wipe off (default position)

Automatic wipe

By turning the lever to the automatic wipe (1), the wipers will operate automatically. Select sensitivity adjustment level on the central screen to adjust the interval of automatic wipe.

Rain sensor is equipped in the interior rearview mirror base to detect varying amounts of water outside of the windscreen. With automatic wipe, the vehicle will adjust the wiping speed according to the signals provided by rain sensor.

Note: If the sensitivity level of the rain sensor is increased, the wiper will automatically wipe once; If the rain sensor detects a continuous rainwater, the wiper will keep working. When no rain is detected, it is recommended to switch off automatic wipe.

Slow speed wipe

By turning the lever to the slow speed wipe (2), the wipers will operate slowly.

Fast speed wipe

By turning the lever to the fast speed wipe (3), the wipers will operate at a fast speed.

Note: If the wipers are used for quick wiping, some intelligent driving functions (ACC/ Pilot) cannot be activated, or some activated intelligent driving functions

Wipe off

By turning the lever to the OFF (4) to turn off the wiper switch, the wipers will stop wiping.

Note: When the vehicle is stationary, if the bonnet is opened, the front wiper will stop working immediately.

IMPORTANT

- Avoid operating the wipers on a dry windscreen.
- In freezing or extremely hot conditions, make sure that the wiper blades are not frozen or adhered to the windscreen.
- If the wiper or windscreen are covered with snow, sundries, etc., please eliminate them first before using.

Windscreen Wipe and Wash

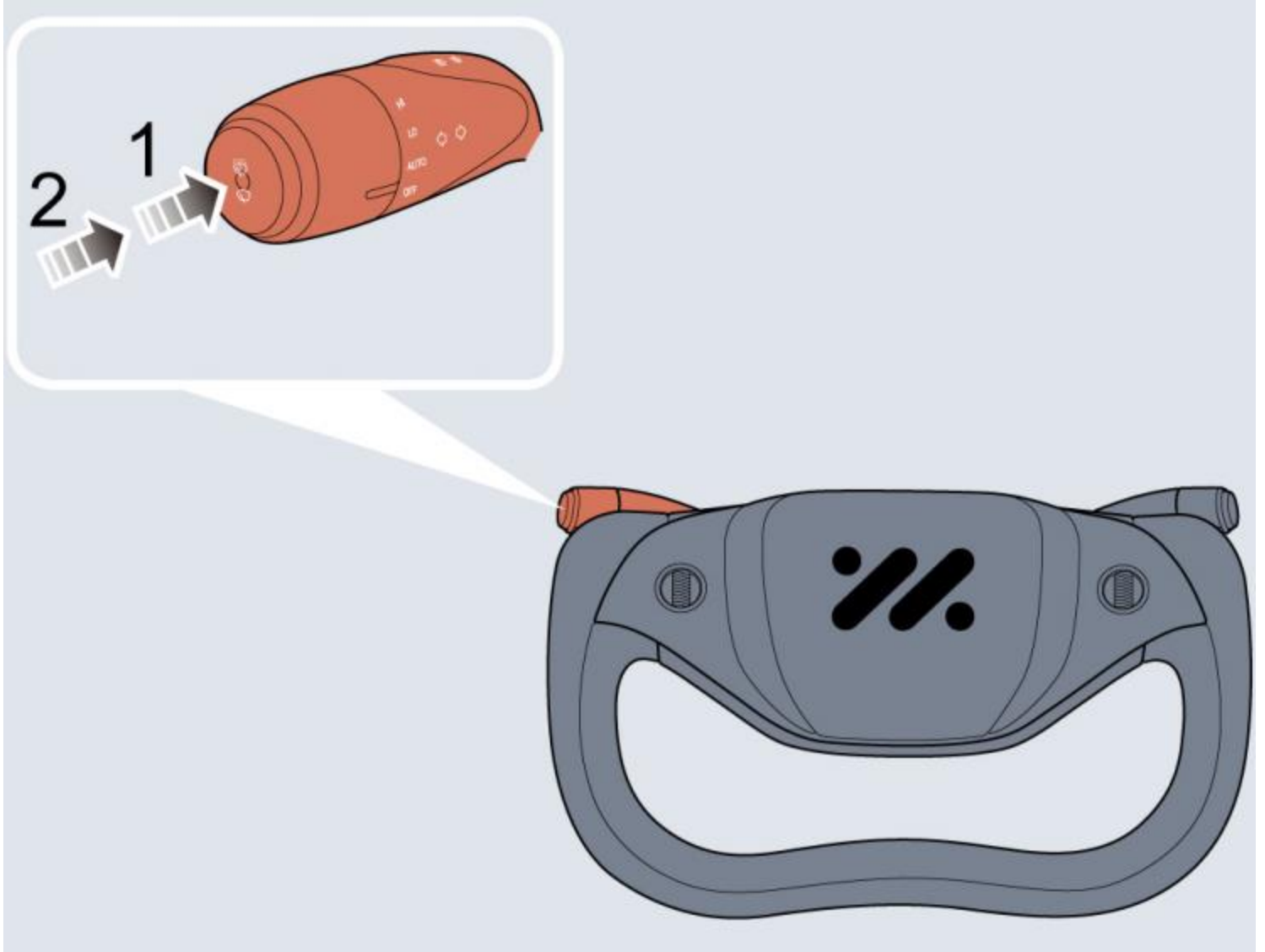

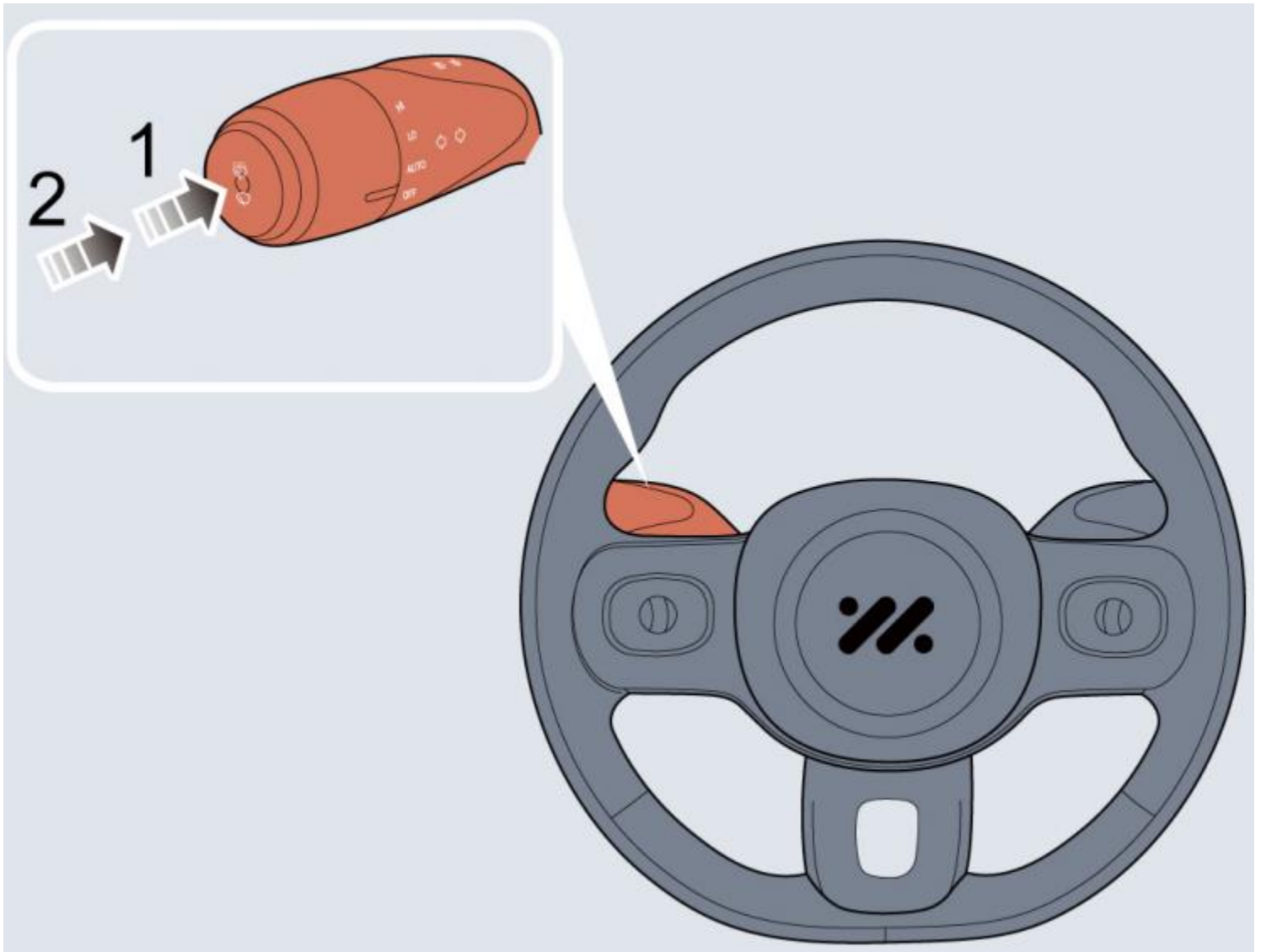

Single wipe (1)

Wipe and wash (2)

Short press the Wipe and Wash button (1), hold for 1 - 2s and release, and the wiper will start single wipe. If the button is held at single wipe (1), the wipers will operate continuously until the button is released.

Long press the Wipe and Wash button (2), the windscreen washer will work immediately. After a short delay, the wipers will commence operating in conjunction with the washers.

IMPORTANT

If the windscreen washer fluid cannot be ejected out, immediately release the Wipe and Wash button to avoid the wipers from spreading dust on the windscreen to affect the vision.

Steering Wheel

Steering Wheel Adjustment

Warning: It is prohibited to adjust the steering wheel position when the vehicle is running to avoid risk.

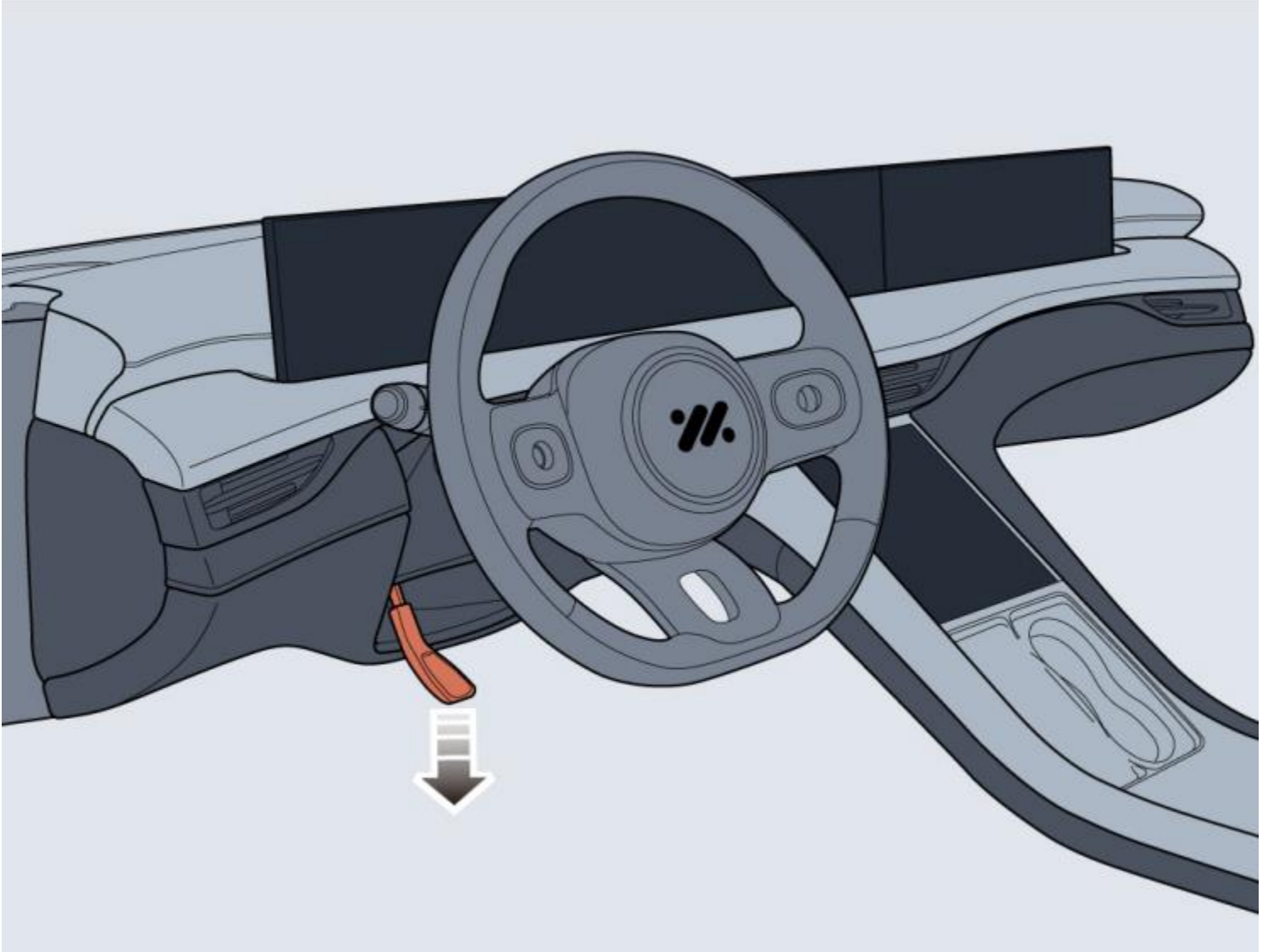

Adjust the position of the steering wheel to suit driving posture:

1. Fully release the locking lever (as arrowed);
2. Hold the steering wheel with both hands and tilt the steering column up or down to adjust the steering wheel height; pull the steering wheel back and forth to adjust the distance between the steering wheel and the driver;
3. Once a comfortable driving position has been selected, pull the locking lever fully up to lock the steering wheel into its new position.

Electric Power Steering (EPS)

This series of models have electric power steering (EPS) function, which can automatically adjust the power steering magnitude. EPS system is available only when the vehicle starts.

IMPORTANT

If the EPS fails, the steering may appear very heavy, which affects driving safety!

Steering feel mode

The vehicle is available in three steering feel modes. When the vehicle is stationary, the user can customize the steering feel on the central screen as required.

1. Lightsome: provides high steering power, with a lightsome feel.
2. Moderate: provides moderate steering power, with a moderate feel.
3. Steady: provides low steering power, with a steady feel.

IMPORTANT

When the EPS is working, holding the steering wheel on full lock for long periods will result in a reduction in steering power, causing a heavier feel to the steering!

If the battery cable has been disconnected for any reason, upon reconnection the yellow MIL for EPS may illuminate. Start the vehicle, and try to turn the steering wheel from the middle to dead left and then to dead right, and the lamp will extinguish.

Steering Wheel Heating

The "Steering Wheel Heating" function can improve the driving comfort at low ambient temperature. This function can be enabled or disabled by clicking the Steering Wheel Heating button in the Seat Adjustment interface of the central screen.

Horn





Press the horn button area on the steering wheel, and the horn sounds.

IMPORTANT

The horn switch area on the steering wheel is also the cover plate of the driver's frontal airbag module. Therefore, to avoid possible SRS issues, please do not press with excessive force or hit the airbag cover when operating the horn.

Instructions for Use of Half-width Steering Wheel

LS6's half-width steering wheel is designed with highly adhesive spherical projection in the three and nine o'clock positions, which is easy to hold and use, facilitating the owner to accurately control the steering angle. It is recommended that during steering, especially after crossing hands, the hands should be put in these positions as much as possible; the design is also good for the owner to accurately operate the roller on the steering wheel and the buttons at the back.

To ensure driving safety, the driver is also recommended to avoid unnecessary aggressive driving.

Rearview Mirror

Common Exterior Rearview Mirror Adjustment

The exterior rearview mirrors can be folded so as to avoid collision or allow the vehicle to pass through a narrow passage.

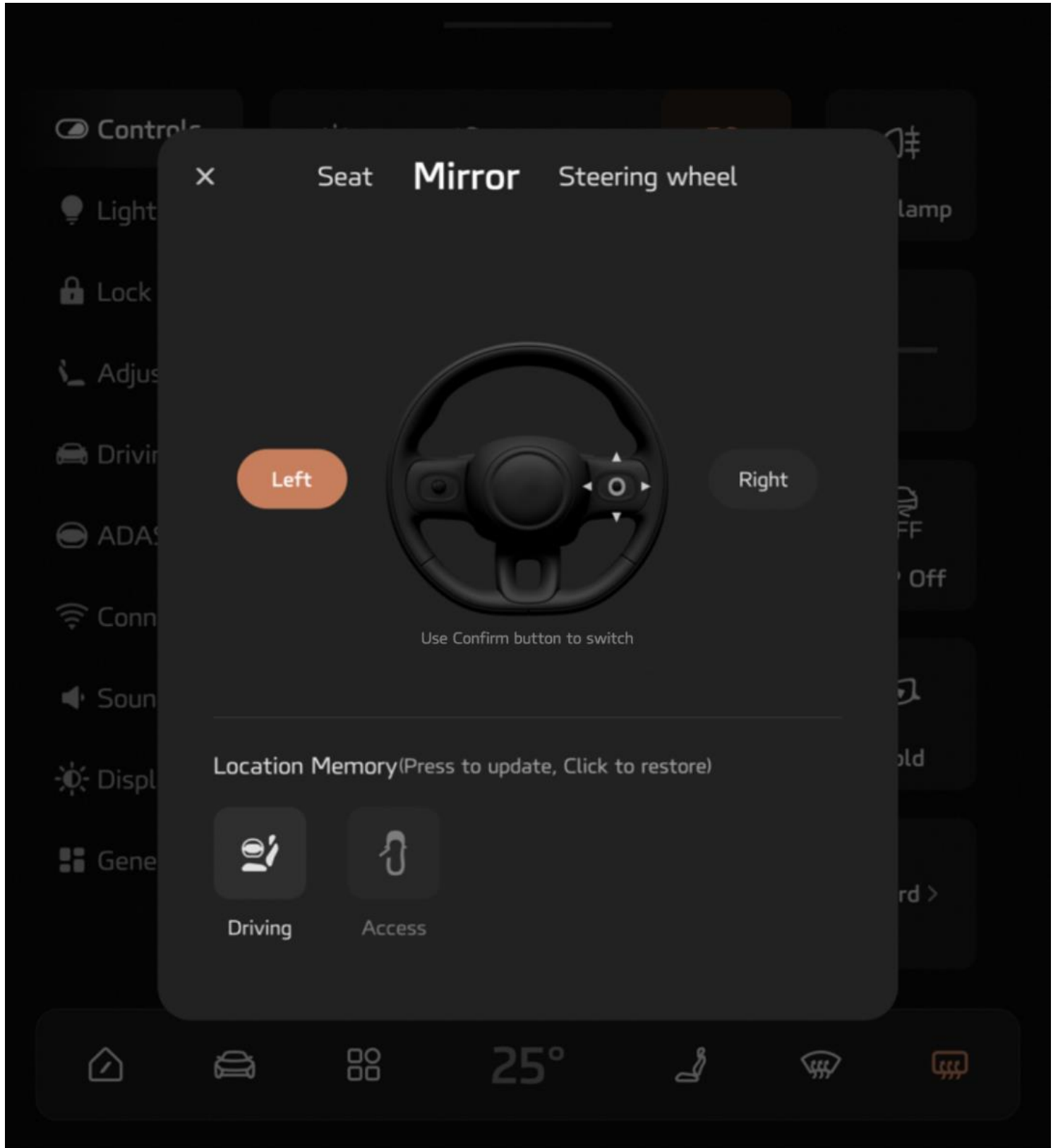

- Select the exterior rearview mirror adjustment function from the "Settings" - "Controls" path on the central screen.
- You can switch between the left and right exterior rearview mirrors by operating the Exterior Rearview Mirror Adjustment interface on the central screen or by pressing the O button on the right of the steering wheel.
- Continuously pressing 4 arrow buttons of Up, Down, Left and Right on the right of the steering wheel can adjust the angle of the exterior rearview mirror.
- Clicking the "Save" button* on the central screen can update and save current mirror angle to the user settings.
- Click the "Restore" button* on the central screen, and the exterior rearview mirror will be automatically adjusted to the angle set.

Note: The vehicles or objects behind viewed in exterior rearview mirrors may appear further away than they actually are.

IMPORTANT

- The adjustment and folding of exterior rearview mirrors are operated with the electric switch, and operating them directly by hand may damage related devices.
- Spraying with high pressure water jets directly in a vehicle wash may result in electric device failure.

Common Exterior Rearview Mirror Folding

The exterior rearview mirrors can be folded so as to avoid collision or allow the vehicle to pass through a narrow passage.

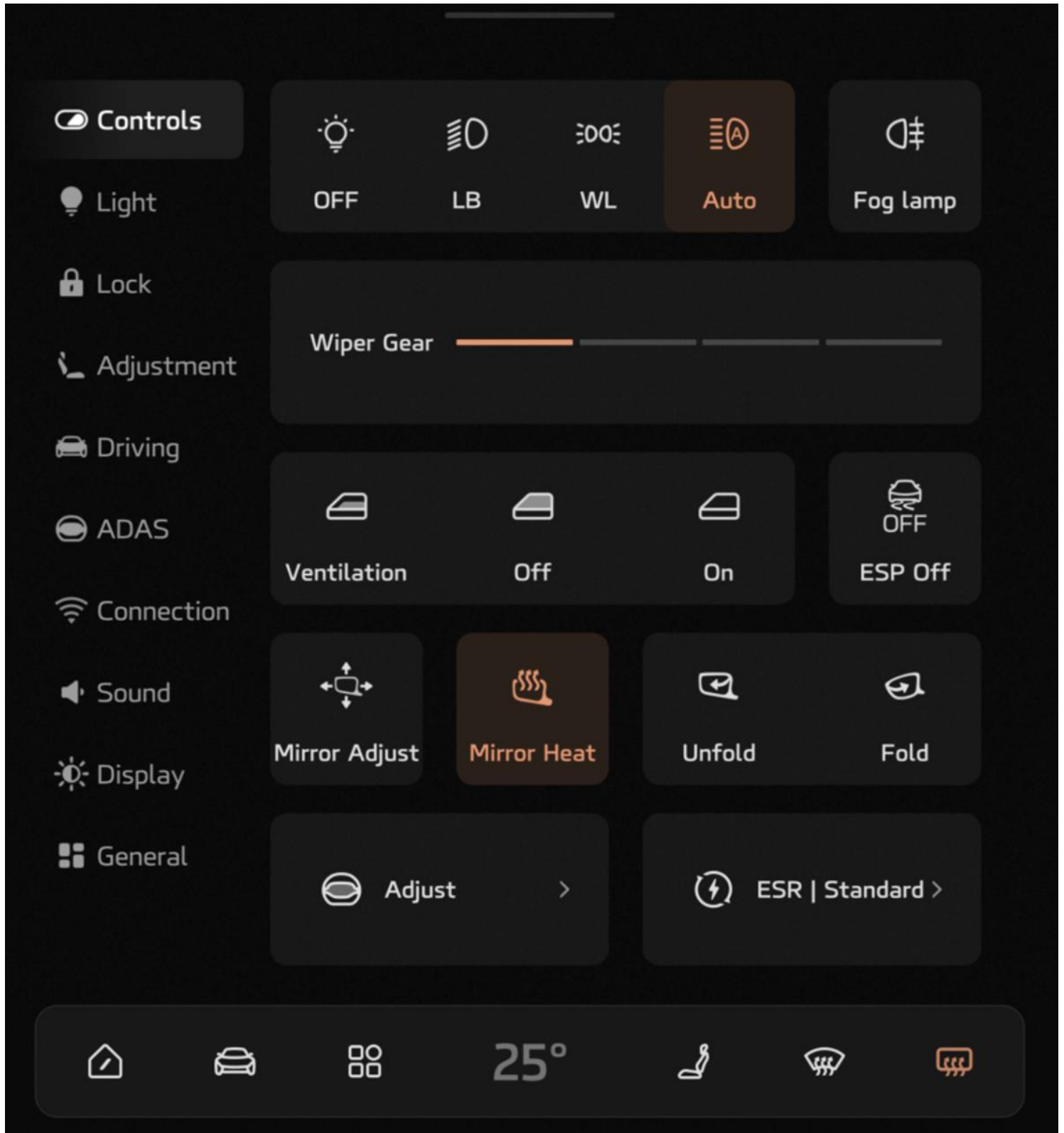

Operate the exterior rearview mirror to fold or unfold it electrically from the "Settings" - "Controls" path on the central screen. Press the "Unfold" button on the central screen, and the exterior rearview mirror will unfold electrically. Press the button again, and the mirror will restore to the folding position.

While unlocking/locking the vehicle, the exterior rearview mirrors will be unfolded/folded automatically.

With the vehicle running, when the speed is greater than 15 km/h, the rearview mirror will automatically unfold, which will only be triggered once in a start cycle; when the speed is greater than 20km/h, the rearview mirror cannot be electrically folded.

Note: If the exterior rearview mirror deviates from original position due to human or other factors, it can restore to the original position by pressing the folding switch to make the exterior rearview mirror fold and unfold once.

Common Exterior Rearview Mirror Heating

The exterior rearview mirrors have integral heating elements which can disperse frost or mist from the glass.

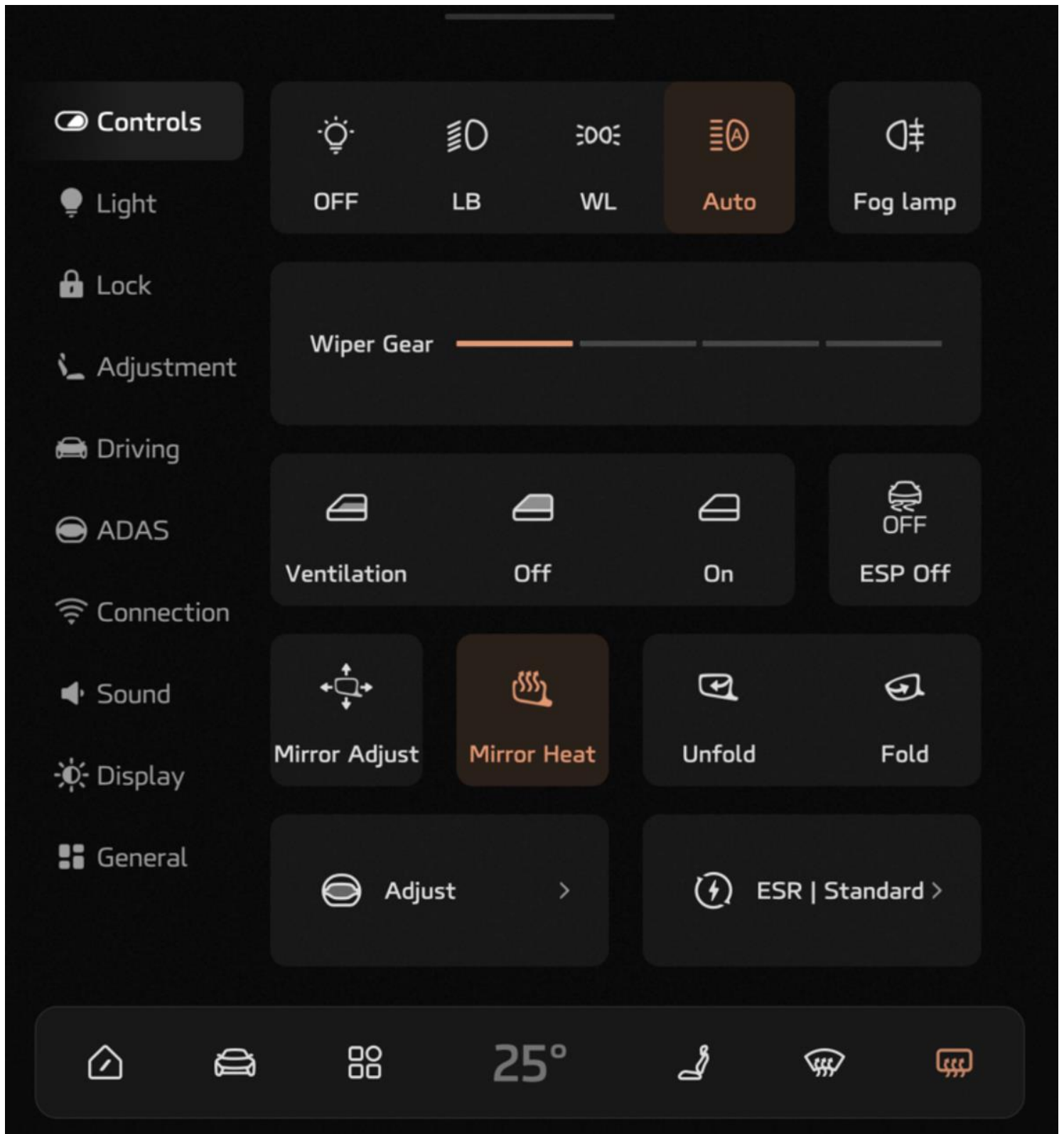

Press the "Exterior Rearview Mirror Heating" button through the "Settings" - "Controls" path on the central screen to enable or disable the exterior rearview mirror heating function.

Common Mirror Angle Downward Inclination of Exterior Rearview Mirror during Reversing

To facilitate the driver to see the rear wheels and the road surface behind the vehicle during reversing, some models are provided with the mirror angle downward inclination memory function of exterior rearview mirror during reversing. This function can be enabled or disabled on the central screen.

- When reversing is required, the mirror downward inclination angle can be set as follows.
- Start the power system and engage in R gear;
- Adjust the exterior rearview mirror glass on both sides to make them incline downward to an appropriate angle;
- Switch from R gear to other gear;

Note: During reversing, if the set mirror downward inclination angle is changed again, then such angle will be automatically memorized after the vehicle is switched from R gear to other gear, and used as the automatic mirror downward inclination angle for next reversing.

Foldable Interior Rearview Mirror

Warning: Do not fold the interior rearview mirror at will when the vehicle is running, otherwise it may cause serious accident.

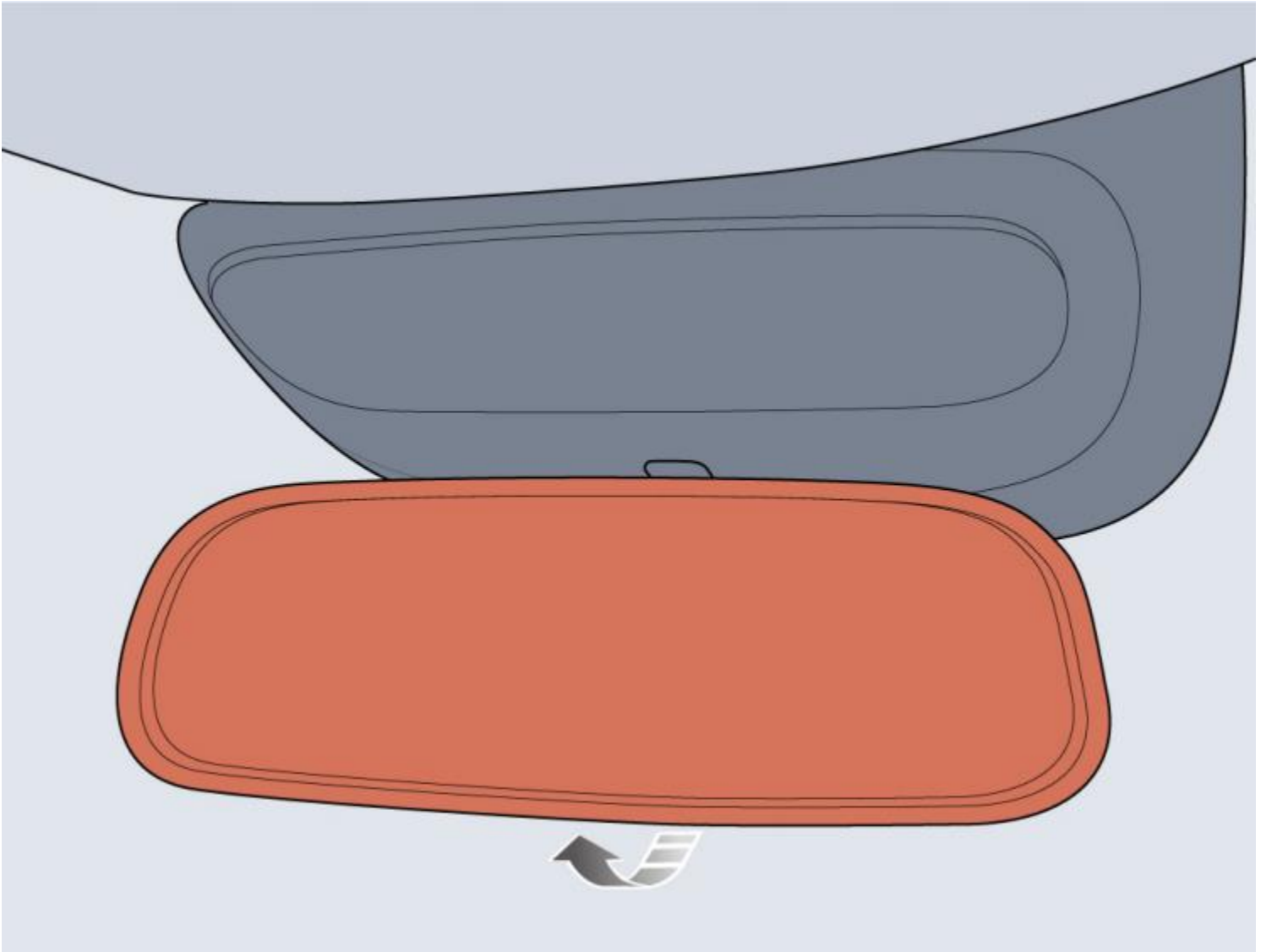

The interior rearview mirror can be folded upward to provide wider field of vision.

Note: The interior rearview mirror can be folded only when no other vehicle behind is confirmed.

Window

Power Operated Window Switch

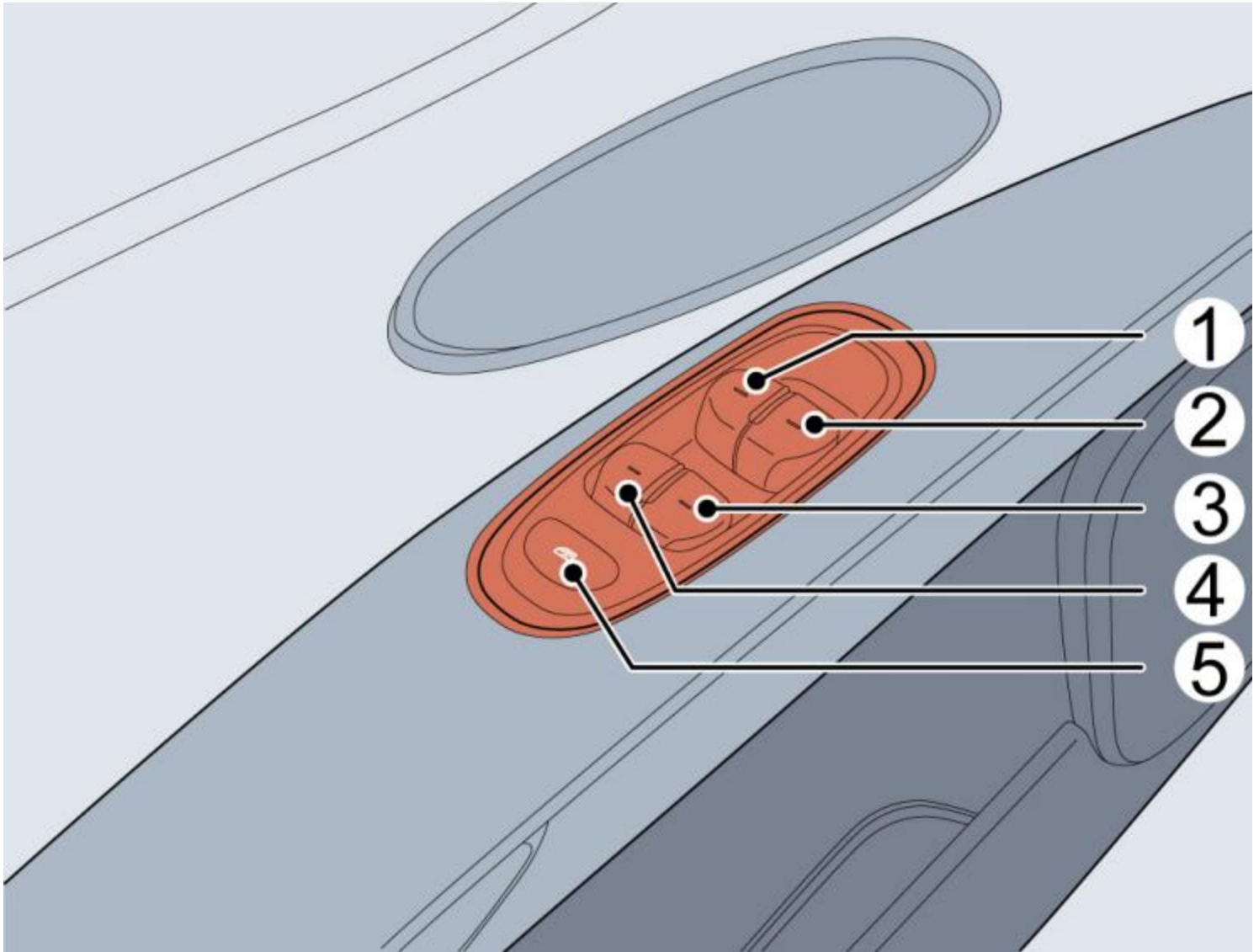

1. Front Left Window Switch
2. Front Right Window Switch
3. Rear Right Window Switch
4. Rear Left Window Switch
5. Rear Window Isolation Switch

Window Operation

The electric windows can be operated when the vehicle is powered on (Doors should be closed during operation).

Press the switch (1-4) to lower the window, and pull up the switch to raise the window. Release the switch, the window will stop moving (unless in "one-touch" mode).

"One-touch" Down

The window control switches (1-4) for four doors are set with two positions; short press to the 2nd position, and the window will automatically open. When the window is moving down, its movement can be stopped at any time by operating the switch again.

"One-touch" Up and Anti-pinch

All window switches have the "One-touch" Up and "Anti-pinch" function. When short pressing the window control switch, the window will automatically ascend to close. Window movement can be stopped at any time by briefly operating the switch again during ascent. The "Anti-pinch" function is a safety feature which prevents the window from ascending and descends automatically a certain distance if an obstruction is sensed.

Note: The front and rear windows can also be operated by individual window switch mounted on each door. The rear window switches will not function if the rear window isolation switch on the driver door has been activated.

Rear Window Isolation Switch

Press the switch (5) to isolate the rear window controls (an indicator lamp in the switch illuminates), and press it again to restore control.

Note: It is recommended that you ISOLATE the rear window switches when carrying children.

Note: Please operate the windows correctly to avoid danger, the driver shall instruct the occupants on the use of windows and safety precautions.

Note: If the battery is cut off or the motor fails during the window lifting/lowering process, the "One-touch" Up and "Anti-pinch" modes will fail. After the vehicle is powered on again, fully close the window with the window switch when the door is closed and then fully open the window after touching the button for about 5 seconds. The window will resume the "One-touch" Up and "Anti-pinch" modes by touching the button for about 5 seconds.

Note: The Automatic Window Closing during Vehicle Locking function has the risk of high temperature burn or endangers life safety, therefore, before activating this function, you must ensure that the passengers, especially the children, have left the vehicle.

Sunroof and Sun Visor

Sunroof

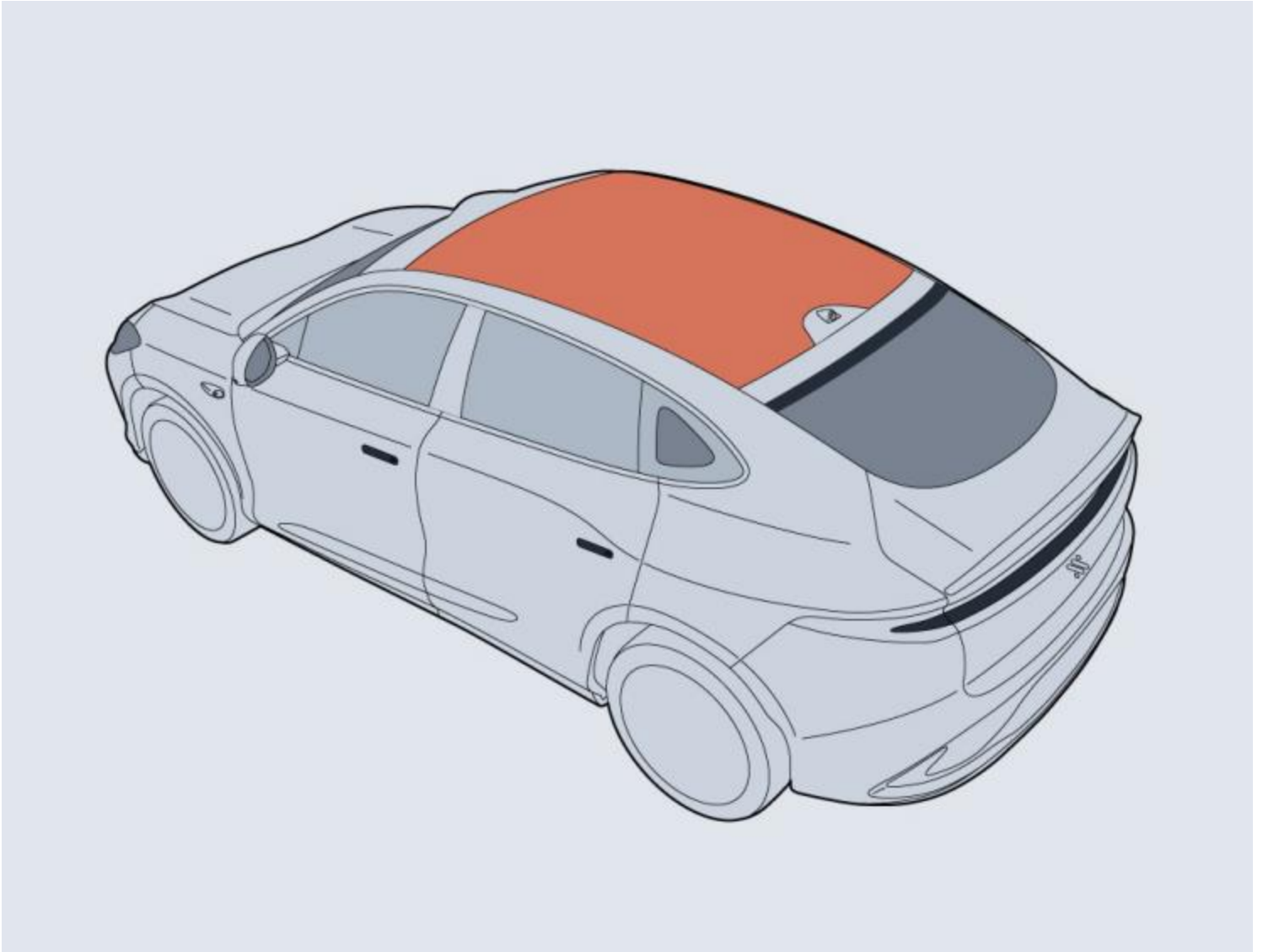

This vehicle is equipped with a fixed glass sunroof with good lighting, so that the compartment is bright.

Sun visor

Warning: The vanity mirror on the driver side should only be used when the vehicle is stationary.

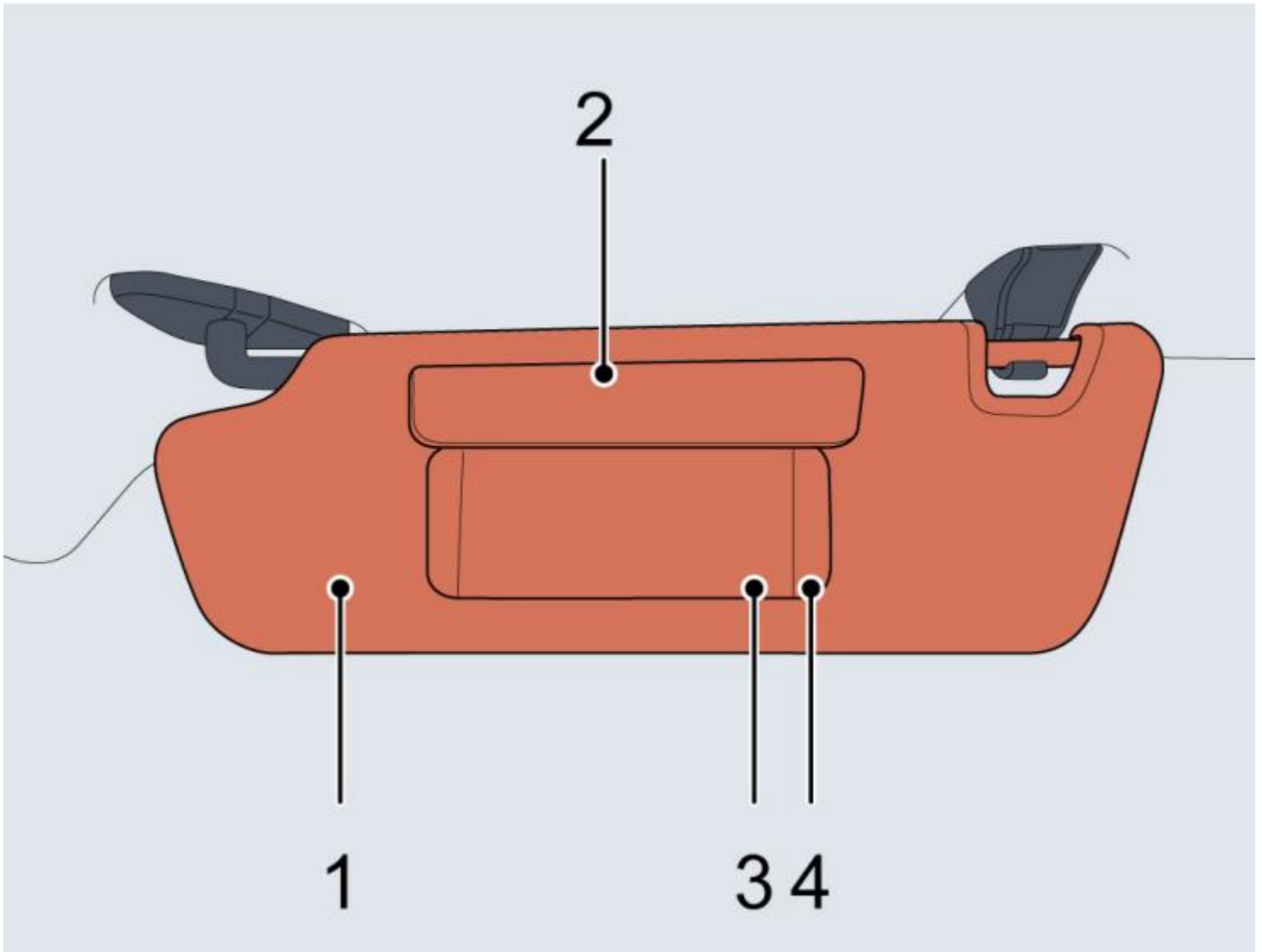

1. Sun visor
2. Vanity mirror trim panel
3. Vanity mirror
4. Vanity mirror light



Sun visor (1), vanity mirror (3) and vanity mirror light (4) are arranged above the heads of both the driver and the front passenger.

If the sun visor is required, it can be unfolded outward. Turn downward to open the vanity mirror trim panel (2), so that the vanity mirror can be used. When the vehicle is powered on, a vanity mirror light will be switched on when the trim panel is opened, and it will be switched off when the trim panel is closed.

Power Socket

Front Power

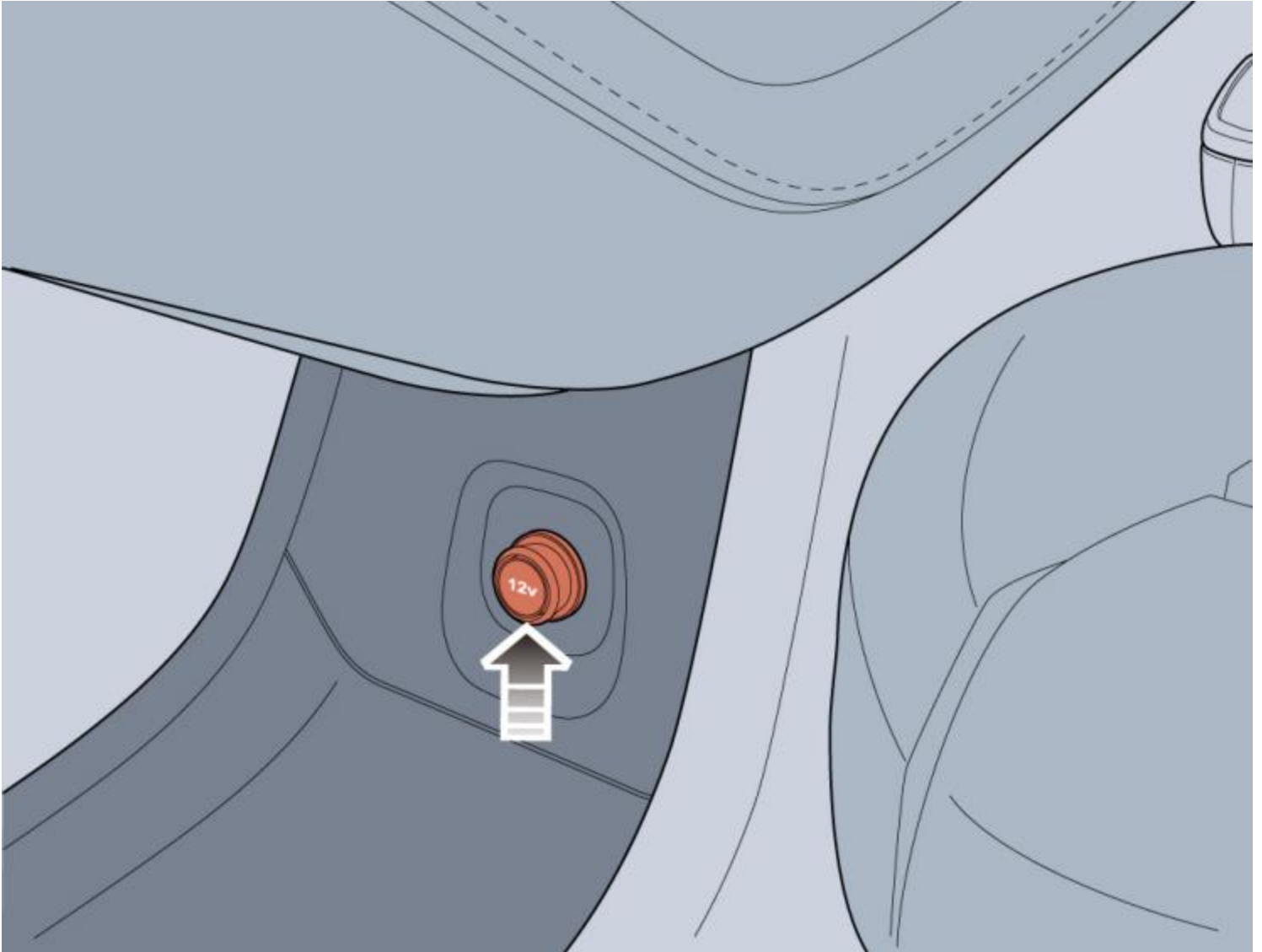

- The 12V front power socket is located below the front of centre console, and can be used as a power supply when the vehicle is powered on.

Warning: Please ensure that the plug is inserted when the 12V power socket is not in use, otherwise foreign objects may enter the socket to affect its use or even cause short circuit.

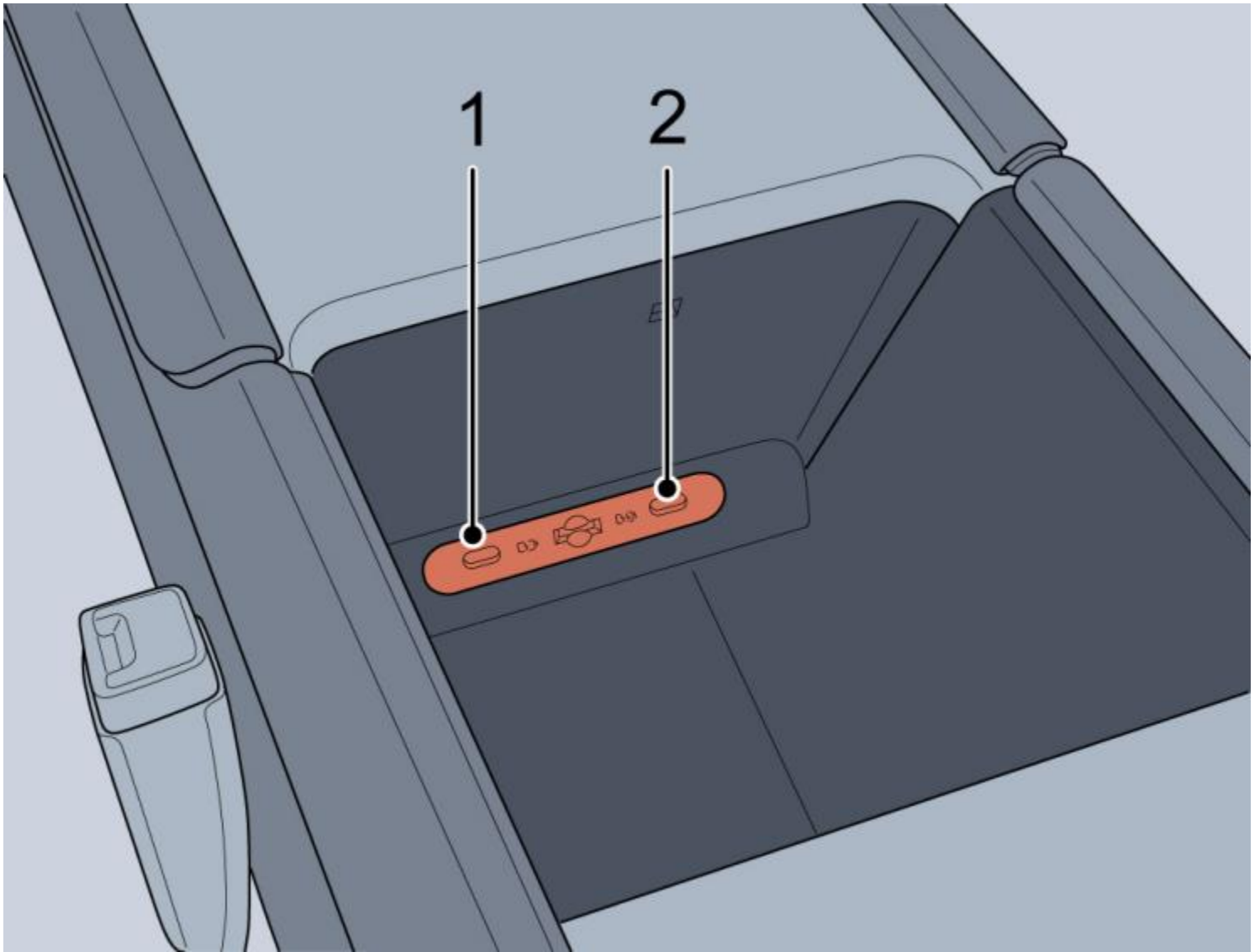

- Two more Type C ports are installed inside the centre console armrest box as a power supply or data transmission interface.
Note: The voltage of the front console power socket is 12V, and its power is 120W; the power of the front Type C port is 15W (1) or 60W (2), and its output current is 3A. Please do not use an electrical appliance with its power exceeding the rating.
Note: It is not recommended/prohibited to use the front console power socket or Type C port when the vehicle is not powered on. When the vehicle is not powered on, the use of front console power socket or Type C port will consume battery power; long-time use may cause battery drain, and the engine can not be started.
Note: The Type C port of this vehicle may not support certain fast charging devices.
Note: No cigarette lighter is available on the vehicle. If required, please consult your Authorised Repairer.

Rear Console Power

There is one Type C port equipped at the rear of the centre console.

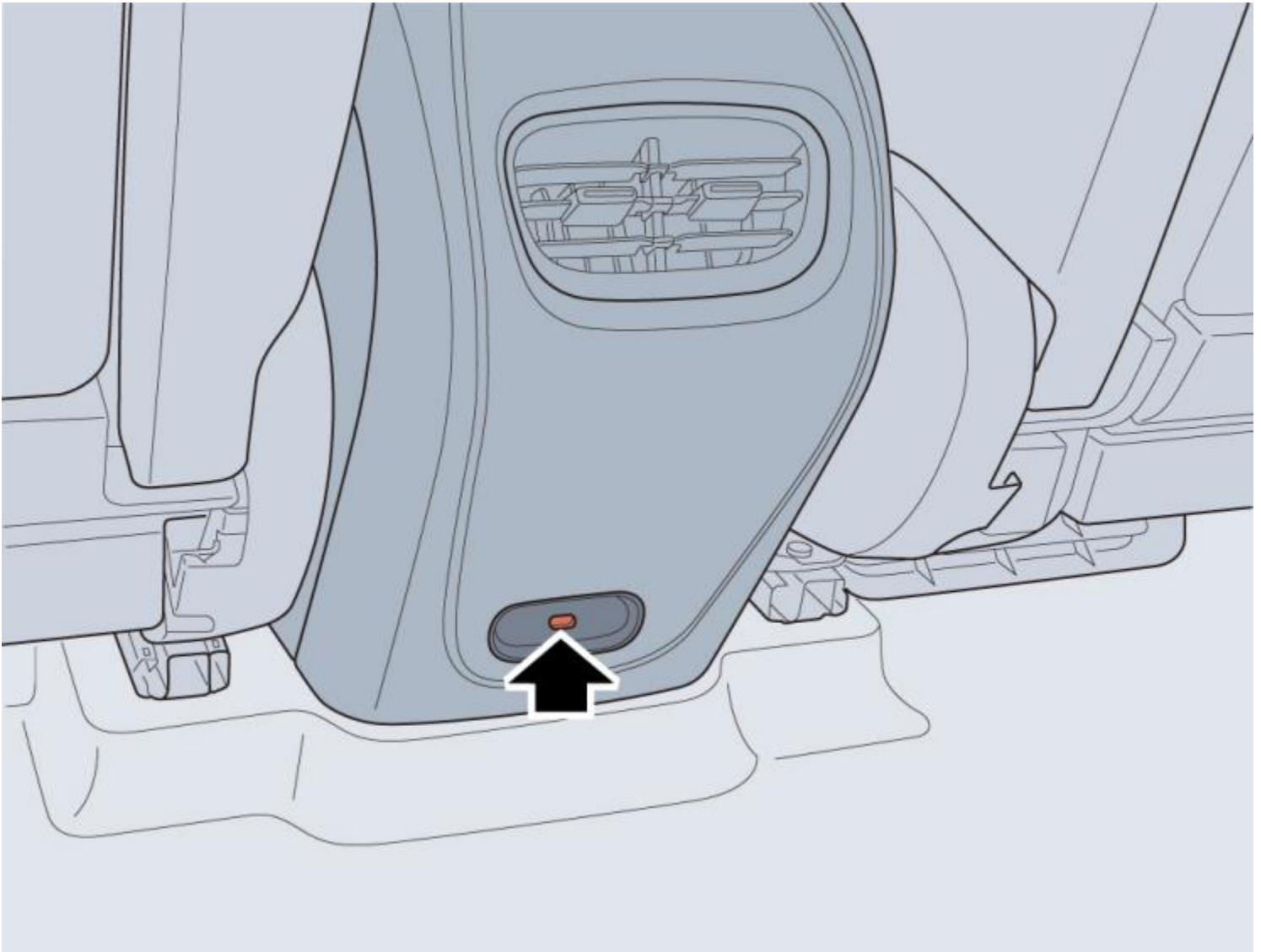

Note: The power of the rear Type C port is 15W, and its output current is 3A. Please do not use an electrical appliance with its power exceeding the rating.

Note: It is prohibited to use the rear Type C port when the vehicle is not powered on. When the vehicle is not powered on, the use of rear Type C port will consume battery power; long-time use may cause battery drain, and the engine cannot be started.

Note: The Type C port of this model may not support certain fast charging devices.

Trunk Power Supply

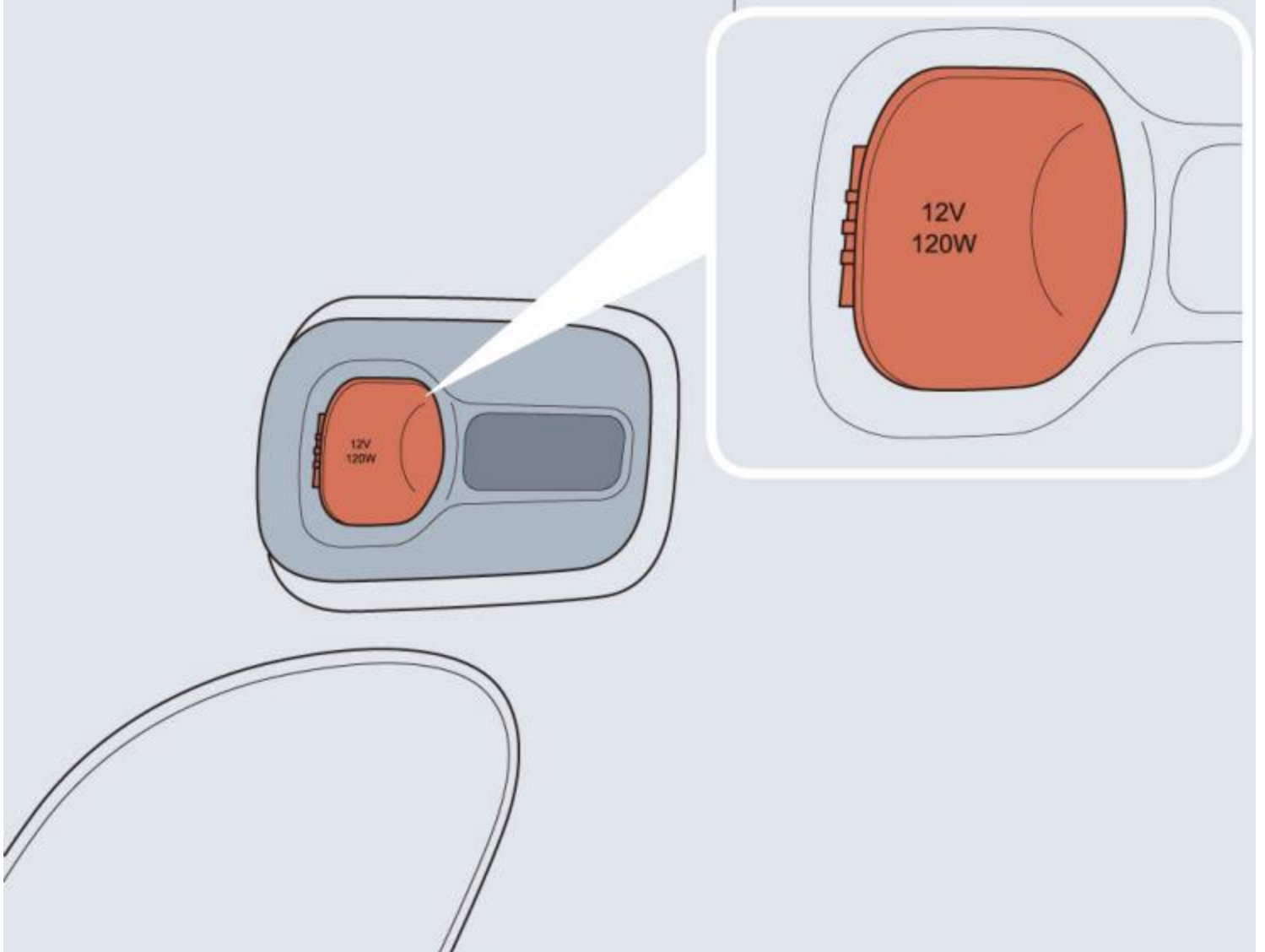

Trunk power socket is located on the left of the trunk. The maximum operating voltage is 12V, and the maximum power is 120W. When the vehicle is powered on, open the lid of trunk power supply to use it as a power supply.

Wireless Charging of Mobile Phones

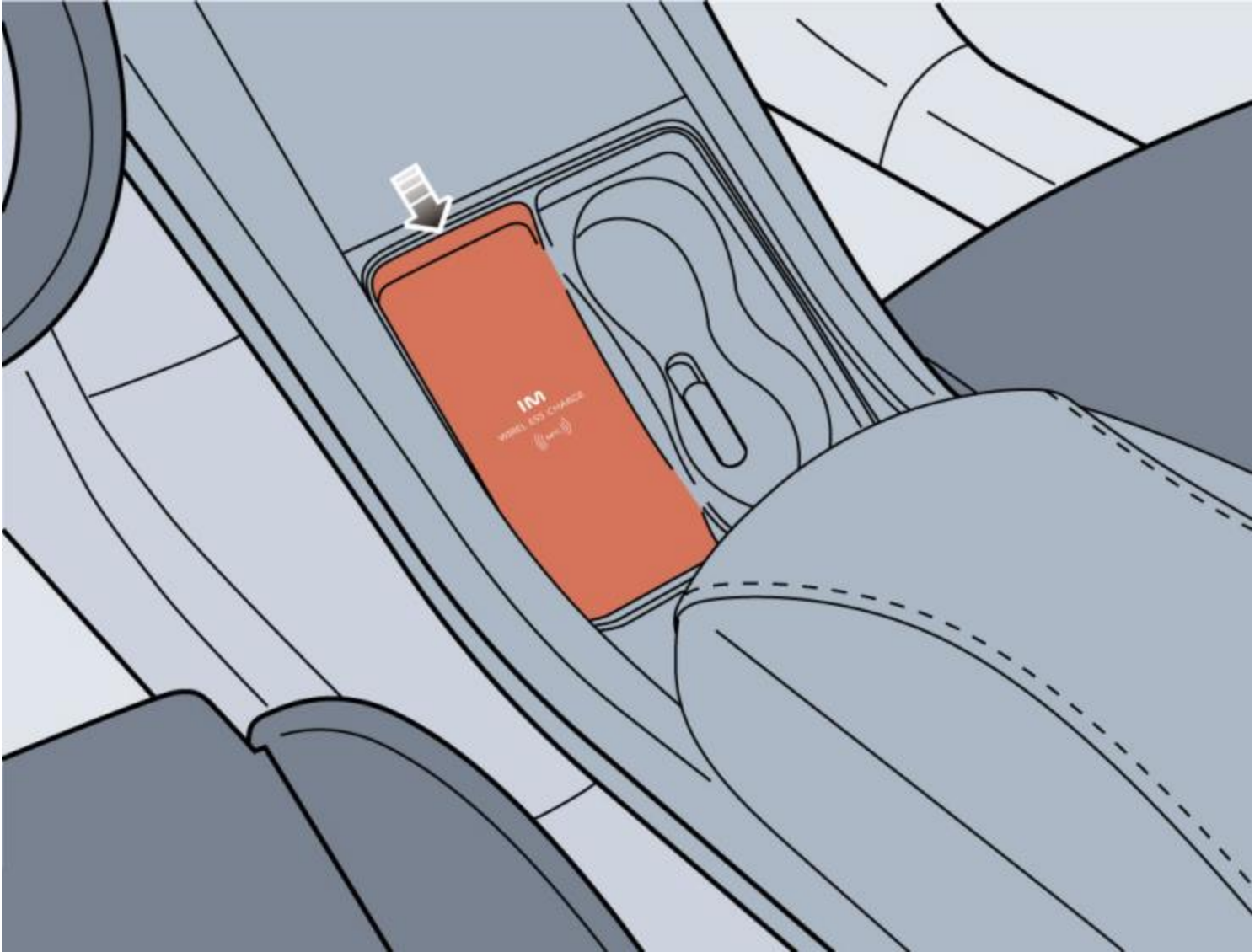

The wireless charging function of the mobile phone is to realize the charging of the mobile phone under the condition that the mobile phone does not need a wire connection through electromagnetic induction.

Note: The wireless charging function only applies to WPC Qi certified mobile phones.

The mobile phone wireless charging area is located at the centre console, and the wireless charging function can be used when the vehicle is powered on.

Note: Only one mobile phone can be charged at a time.

Note: In order to achieve better charging effect, place the mobile phone on the wireless charging panel completely, and align the centre of the mobile phone with the centre of the wireless charger (position of the charging area character).

Note: When the driver is not in the vehicle, do not charge the mobile phone in the vehicle to avoid potential safety hazards.

Note: Wireless charging of mobile phone may be intermittent when driving on bumpy roads. If the mobile phone deviates from the charging area and stops charging, you need to move it back to the chargeable area.

Note: The sizes of different brands of mobile phones are different, and the positions of charging coils in the mobile phones are different.

Please adjust the position of mobile phone appropriately. In addition, the shell of some mobile phones may affect wireless charging.

If the mobile phone cannot be charged properly, please make sure that there is no foreign matter in the wireless charging area or wait for the wireless charging area to cool down before further attempt. If it still cannot be charged, please contact your Authorised Repairer.

Loading in the Vehicle

Instructions for Loading in the Vehicle

- Please close all storage devices when the vehicle is in motion. Leaving these storage devices open may cause personal injuries in cases of a sudden start-off, emergency braking and a car accident.
- Do not place flammable materials such as liquid or lighters in any storage devices. The heat in hot summer may ignite flammable materials and lead to a fire.

Warning: DO NOT carry unsecured equipment, tools or luggage that could move, which may cause personal injury in the event of emergency braking, steering or traffic accidents.

Warning: DO NOT obstruct the driver and passengers to keep right sitting posture and observation with loads.

Warning: Do not place hot drinks in the cup holder whilst driving. Spillage may result in scald or other unnecessary injuries.

Centre Console Front Storage Box

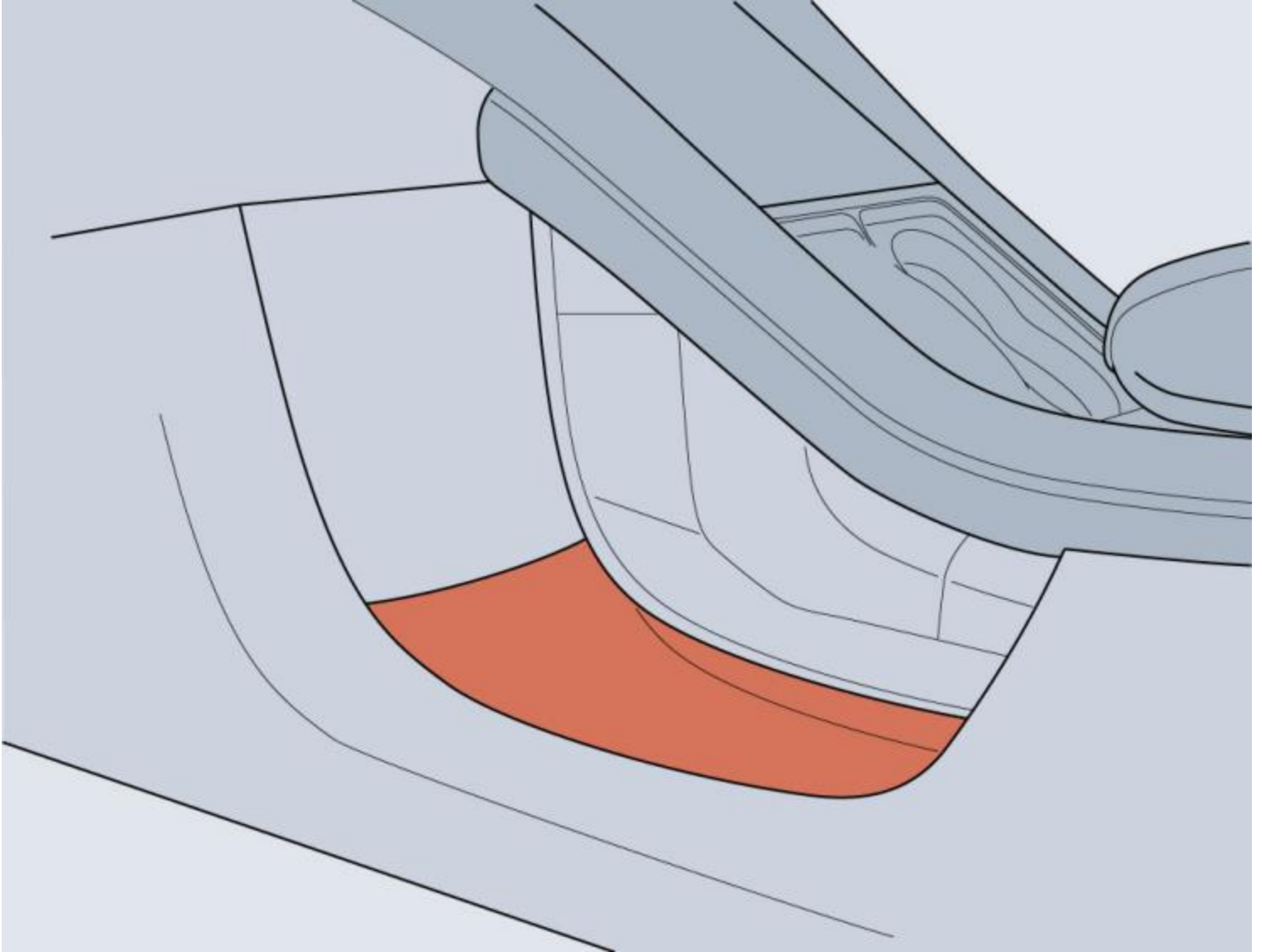

The centre console front storage box is located below the central screen.

Centre Console Armrest Box



Press and hold the unlock button and lift the centre console armrest to open the centre console armrest box, and the centre console armrest box light will automatically illuminate. Exert little force to put down the centre console armrest to close the centre console armrest box, and the light will be automatically turned off.

Note: The centre console armrest can slide forward and backward. To open the armrest box, slide the centre console armrest to the rearmost position first.

Centre Console Cup Holder



The centre console cup holder is located in front of the centre console armrest box.

The centre console cup holder is Open:

Open cup holder allows the cup to be placed directly;

Rear Armrest and Rear Cup Holder

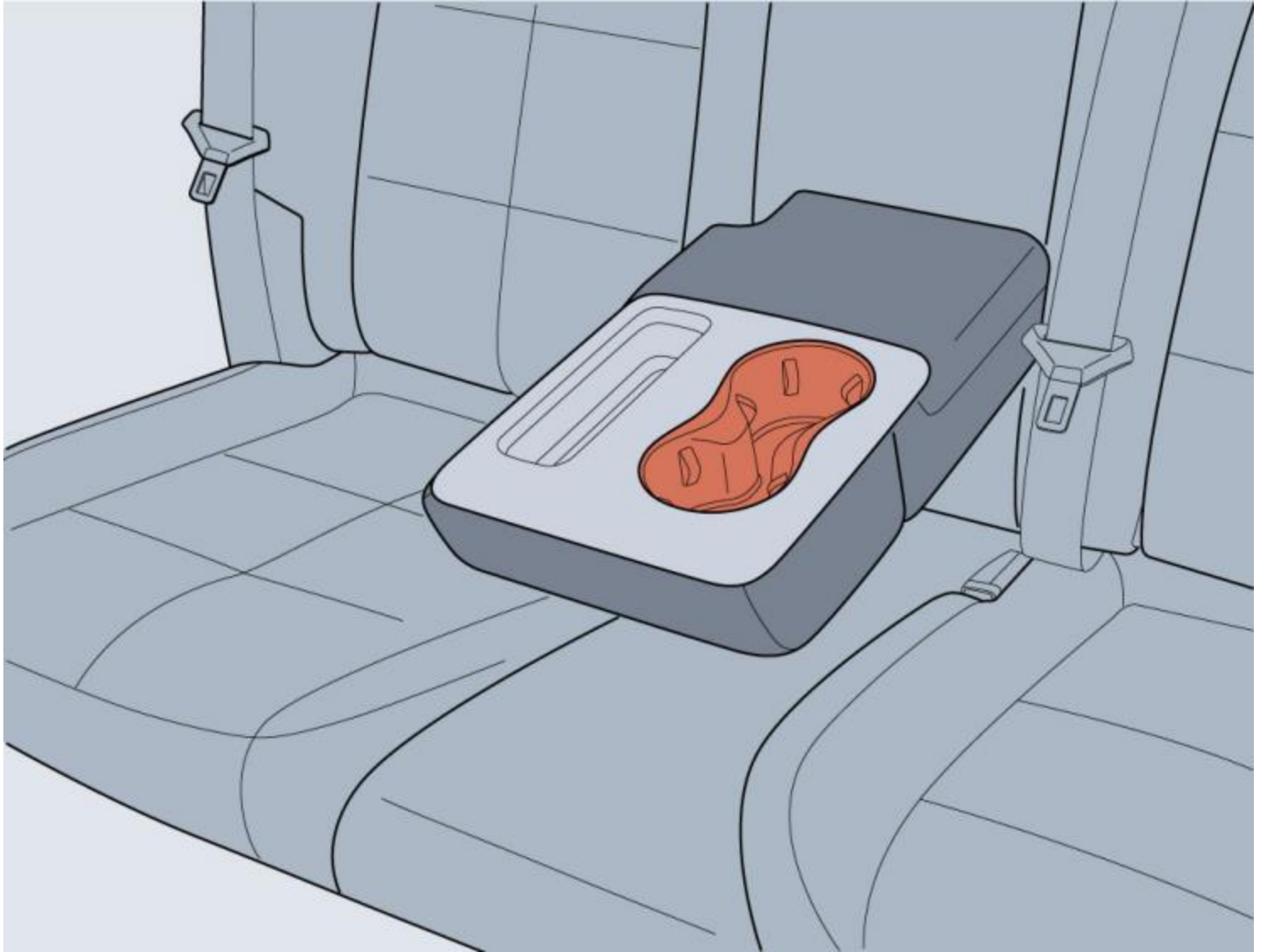

Note: The rear armrest and rear cup holder can be folded into the middle of the rear seat backrest, and can be opened forward when in use.

Tailgate

Tailgate

In severe winter conditions, frozen water may make it more difficult to open the tailgate by operating the tailgate mechanical switch. In this case, you can open the tailgate as follows:

In the screen menu in the cabin, trigger the tailgate unlock function.

Warning: Do not try to release the frozen mechanical switch by using tool or applying force.

Warning:

- If the tailgate can not be closed or the weatherstrip between the body and tailgate is fractured, be sure to close all windows during driving, select the face distribution mode of the air conditioner, and set the blower to maximum speed, so as to decrease the surrounding pollutant gases entering the vehicle.
- Before operating the tailgate, ensure there is no people around placing any part of his body in the position with a risk of being pinched or bruised.
- In case of extreme slope and speed, the tailgate may not be electrically opened or fully closed.
- During manual operation of power tailgate, avoid violent or rapid operation, which may damage the power tailgate system.

Warning: If the system thermal protection is triggered due to continuous operation of the power tailgate for several times within a short period, the system will suspend the power opening/closing function. In this situation, the tailgate can be fully closed manually once, and the function of power tailgate system will be recovered after 3 minutes.

Warning: If the anti-pinch function of the power tailgate is triggered for several times consecutively, the system will suspend the power opening/closing function. In this situation, the tailgate can be fully closed manually once to recover the function of power tailgate system.

Warning: If the power tailgate system fails, and the relevant warning message "Power Tailgate System Failure" and icon are displayed in the message centre of instrument pack, please seek a local Authorised Repairer.

Conventional Opening/Closing Mode of Power Tailgate

The power tailgate can be operated only when the vehicle is in P gear.

1. Manually open/close the tailgate: When the vehicle is unlocked, you can press the dot in the rear mark with your finger (A) to open the power tailgate. When the power tailgate needs to be closed, just press the button (B) on the tailgate interior trim panel.

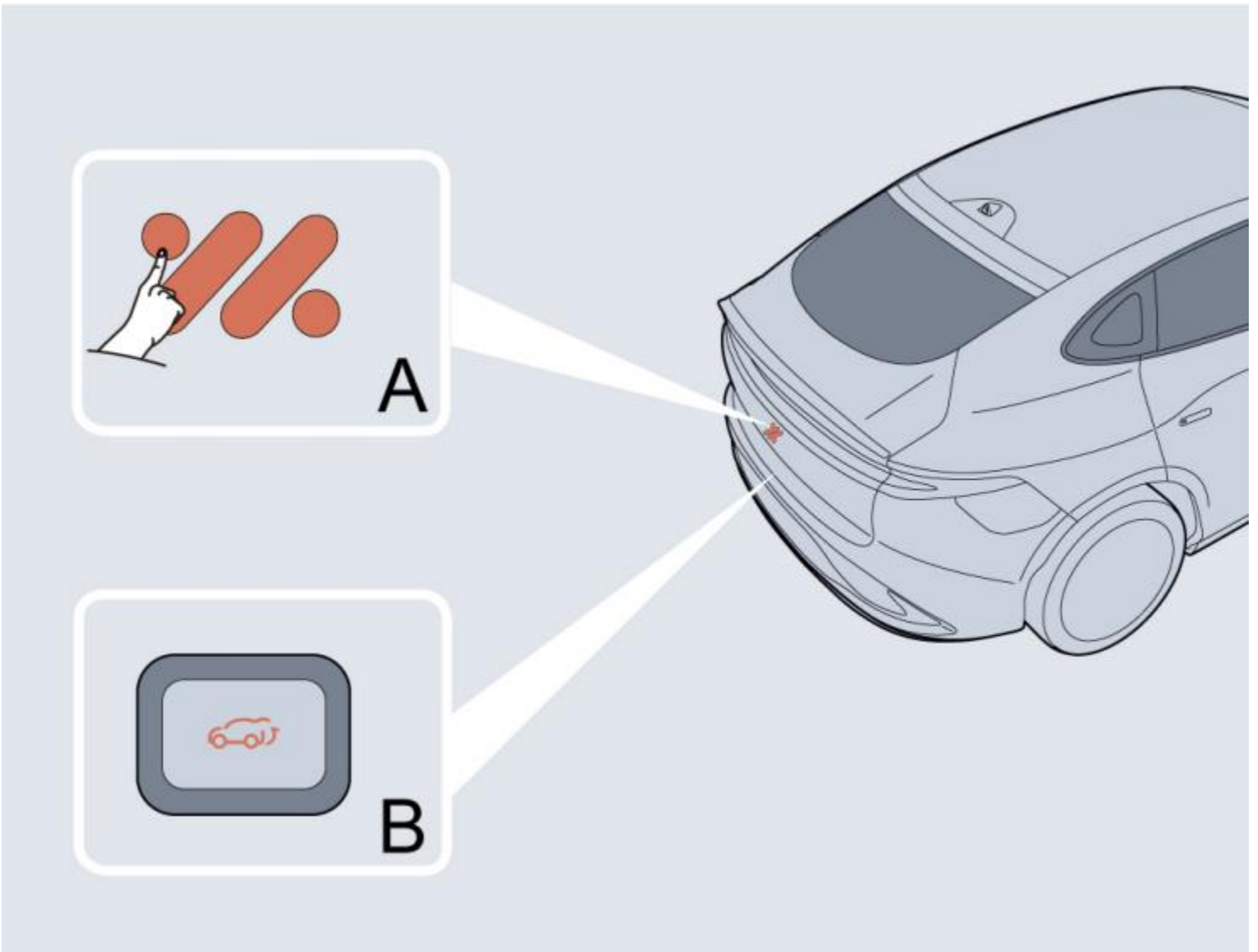

2. Long press the corresponding tailgate icon on the main interface of the central screen to open/close the tailgate.

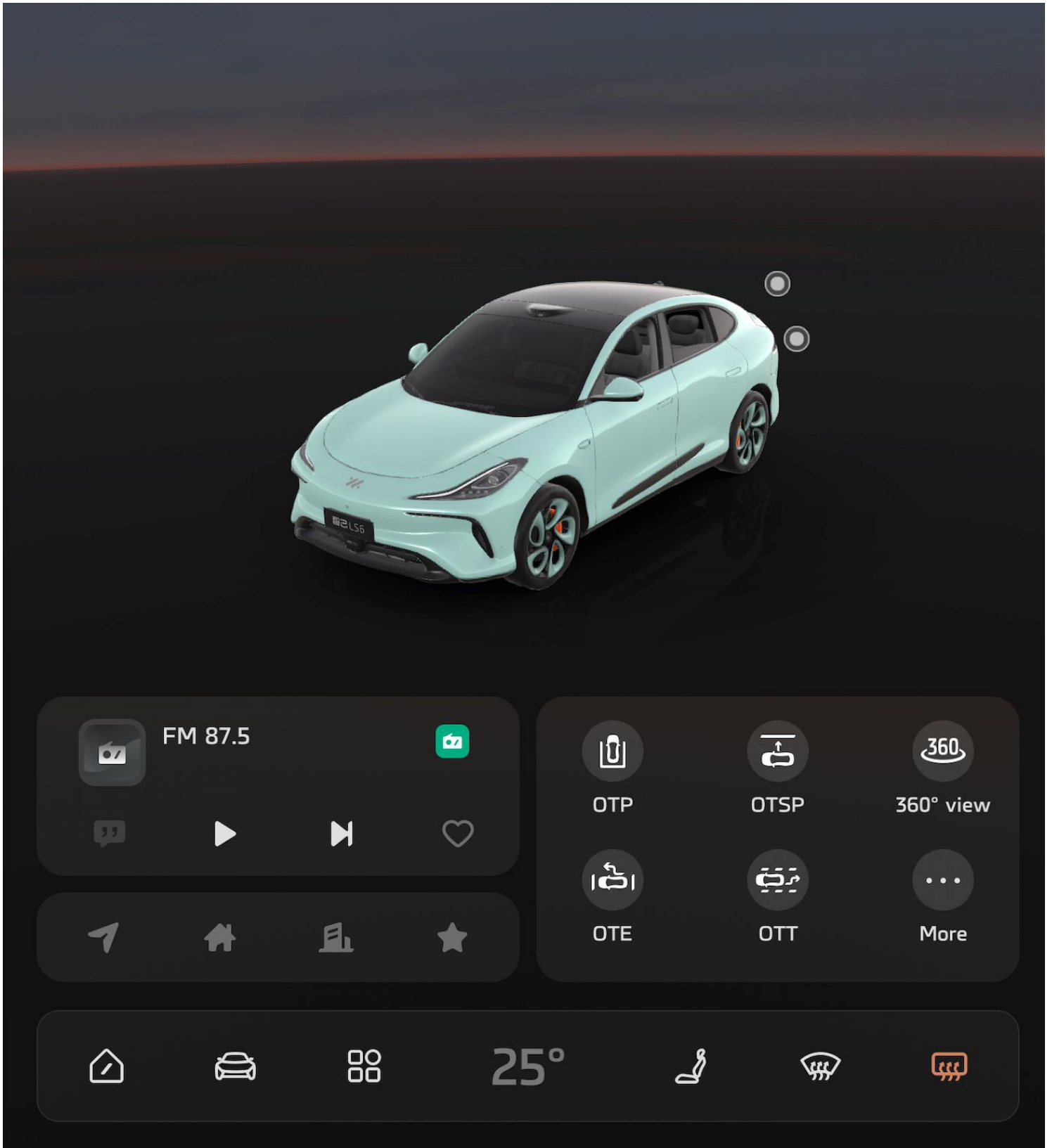

Note: The power tailgate may not function fully at extreme temperatures.

Note: After the tailgate is opened for 15 minutes, the power tailgate function will be disabled in order to save power, and the tailgate must be closed manually after getting off the vehicle!

Note: During automatic car wash, the vehicle remains locked to prevent the tailgate from opening due to accidental touch.

If the tailgate fails to be properly opened to preset height or fully closed, manually close it once slowly and completely to recover the functions of power tailgate system.

Note: During manual operation of power tailgate, avoid violent or rapid operation, so that the power tailgate system will not be damaged.

Opening Height Setting of Power Tailgate

Before opening the tailgate, long press the tailgate button for several seconds, and the tailgate height can be memorized; or the adjustment option of the tailgate height on the Body page can be used to memorize the height.

Users can set the opening height of power tailgate as needed by using the Close button at the tailgate or on the entertainment display. The power tailgate controller will record the new opening height.

Note: Each time the power tailgate opens, it will be at a height from minimum to maximum as set by the user.

Setting mode 1:

1. Place the tailgate to desired setting height, and keep it there.
2. Press and hold the Close button at tailgate for 3s above, the buzzer makes a sound to indicate the successful setting.

Setting mode 2:

1. On the entertainment display, enter the tailgate height setting interface, and move the height setting slider to desired position.

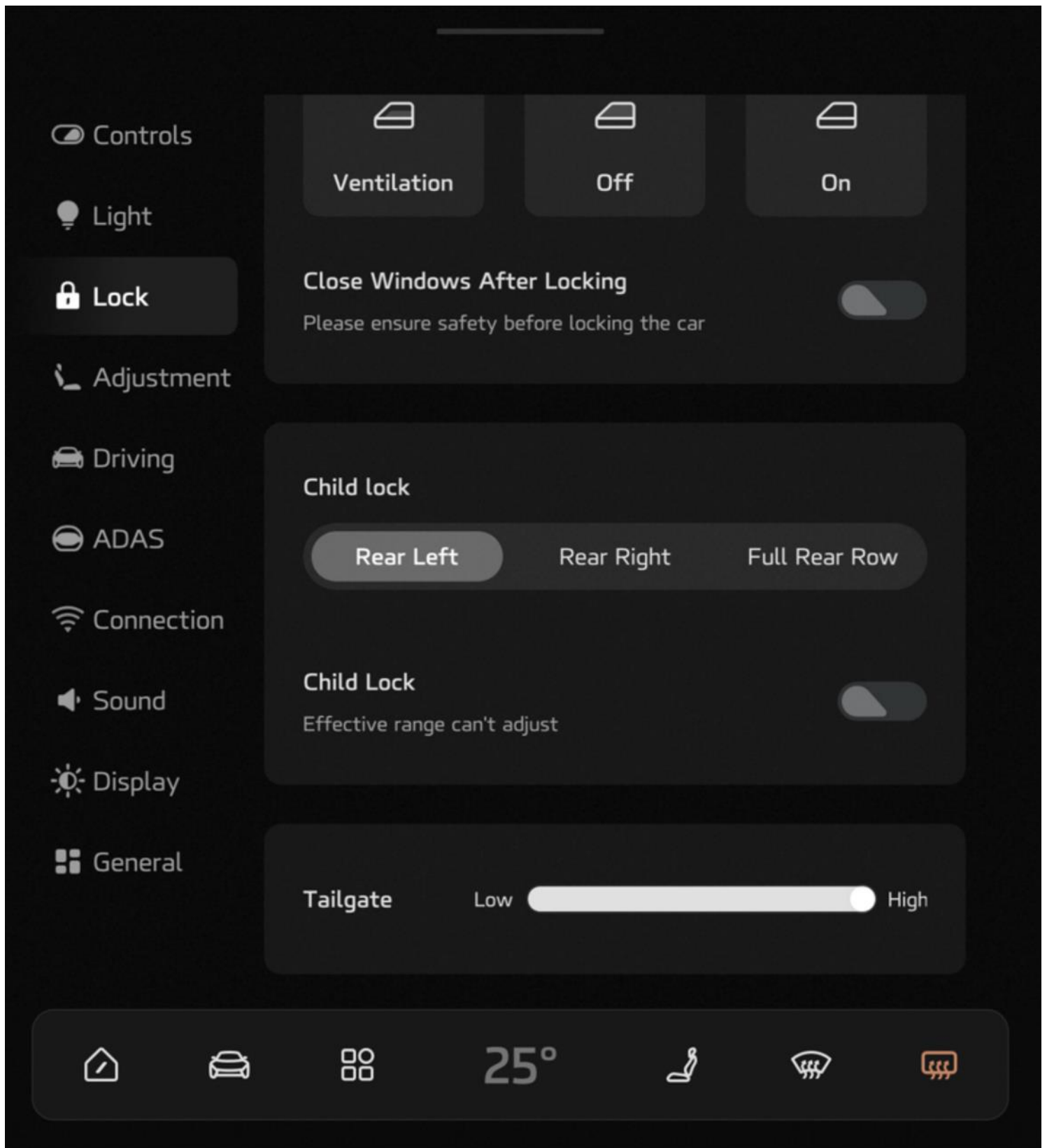

Note: If the power tailgate system failure occurs, relevant warning message "Power Tailgate System Failure" and icon will be displayed in the message centre of instrument pack, please seek a local Authorised Repairer.
Tailgate Emergency Open

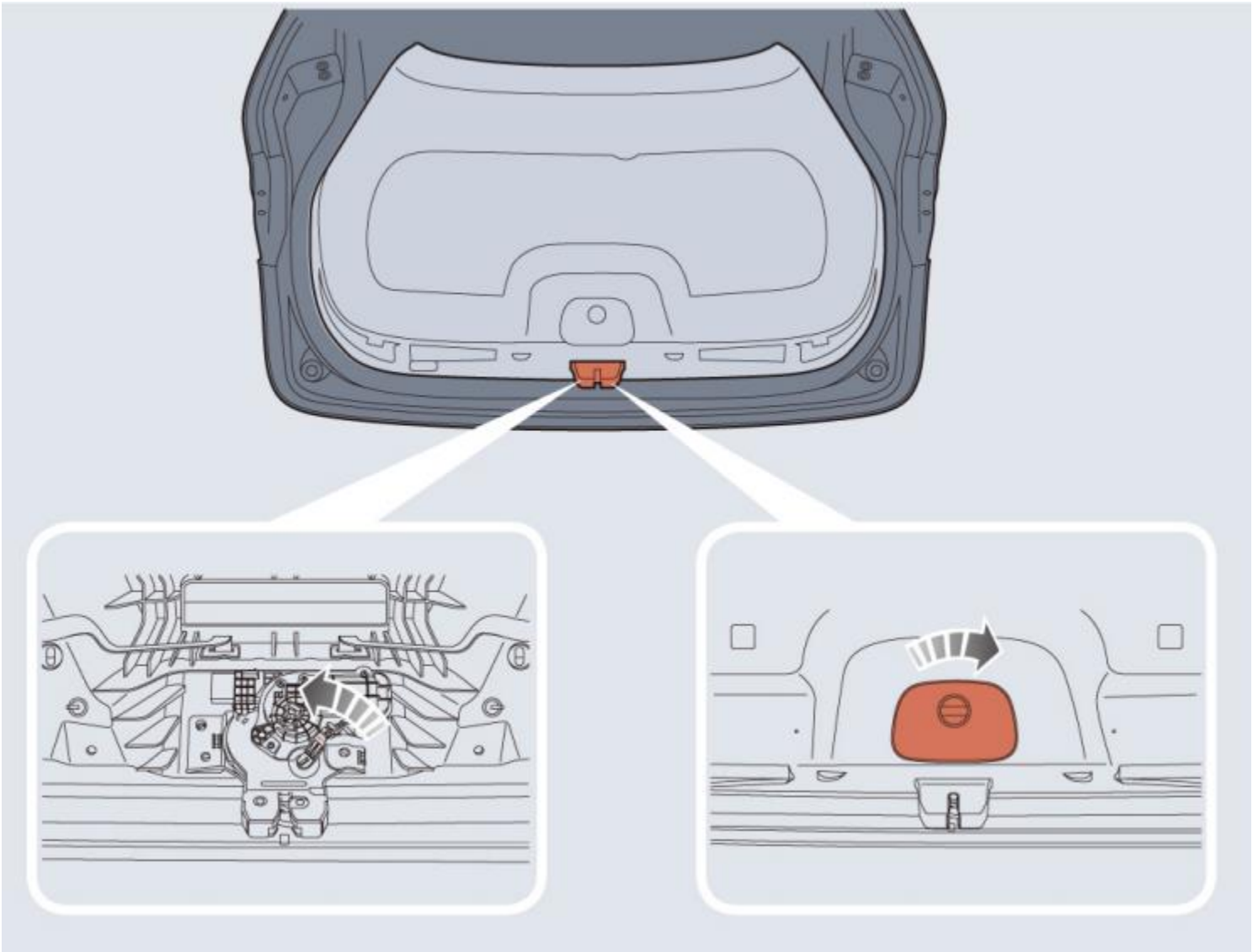

Tailgate emergency open switch is located on the inner side of tailgate lock.
Lower the rear seat to make sure the emergency open plug on the tailgate trim plate can be touched.
Pry open the plastic plug by hand and pull down the plug, so that the tailgate can be opened from inside.

Trunk Loading

When luggage is carried in the trunk, the items should be placed as low and as forward as possible, so as to avoid the cargo shift in the event of an accident or emergency braking.

Folding the rear seats can increase luggage space, refer to "Seat Adjustment and Relevant Functions" section.

Drive carefully and avoid emergency braking or harsh acceleration when large or heavy items are carried.

Warning: DO NOT exceed the gross vehicle weight or the permitted front and rear axle loads, otherwise vehicle damage or casualty accident may be caused.

Warning: Ensure that the rear seat backrests are securely latched in the upright position when loads are carried in the load space behind the seats.

IMPORTANT

Relevant traffic laws and regulations must be observed when loading, and the vehicle shall not be driven with the trunk lid (or tailgate) open.

Infotainment

Smart Screen

Smart Screen Interface Description

Full-screen interaction mode

Smart scene screen

Driver instrument screen

Driver entertainment screen

Front passenger screen



Central screen

Half screen interaction mode

Smart scene screen

Driver instrument screen

Driver entertainment screen

Front passenger screen

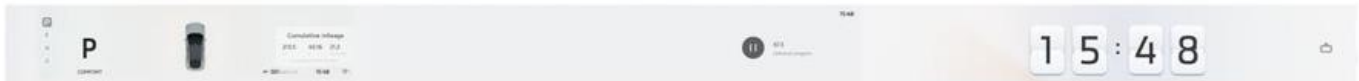

Central screen

The smart scene screen includes the driver screen (driver instrument screen and driver entertainment screen) and front passenger screen

Smart screen interface guide

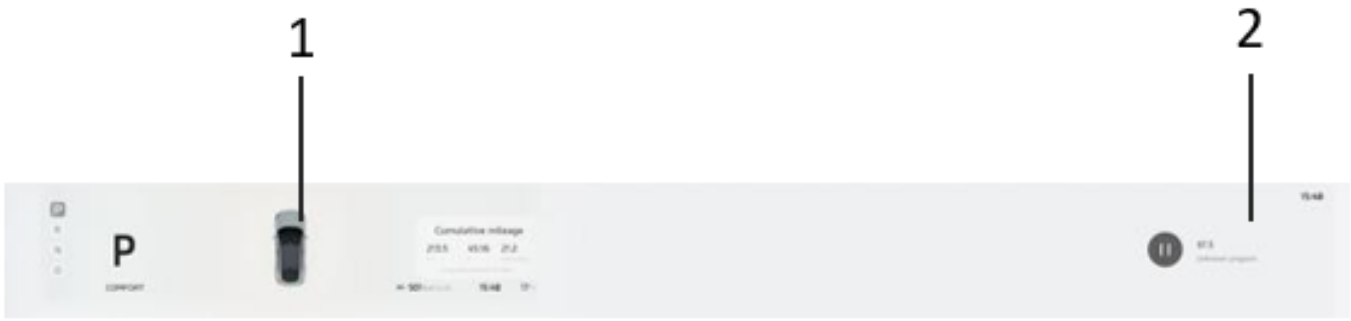

1. Instrument
2. Music

BSD note: When the customer turns on the left turn signal lamp, and the speed is lower than 20Km/h, the road conditions in the front left blind spot vision are displayed on the driver instrument screen; when the speed is higher than 20Km/h, the road conditions in the rear left blind spot vision are displayed on the driver instrument screen. When the customer turns on the right turn signal lamp, the road conditions in the rear blind spot vision are displayed on the driver instrument screen; the BSD will be disabled in half screen mode, and exited when the turn signal lamp is turned off.

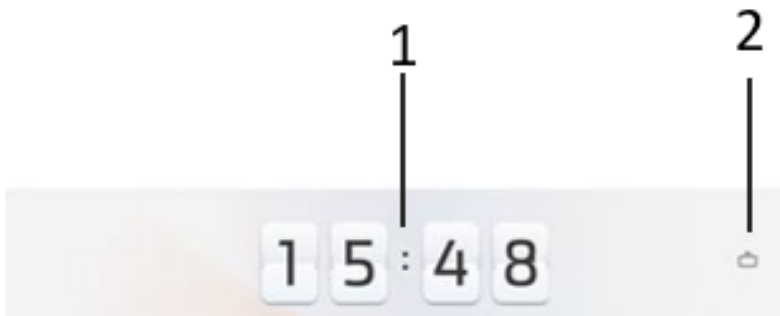

1. Time
2. Lift entertainment screen

System Description

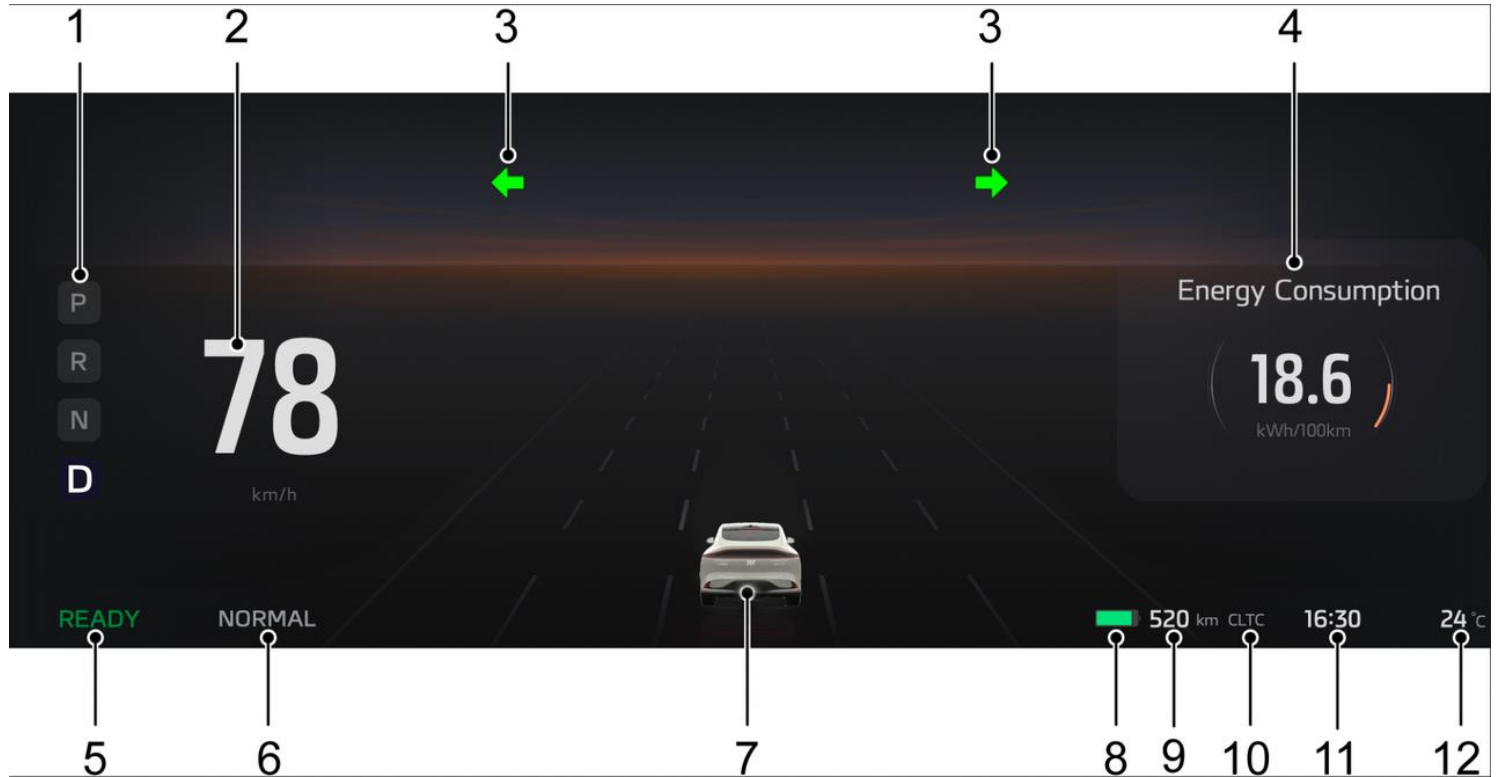

1. Gear display
2. Vehicle speed display
3. Steering information
4. Card information area
5. System ready indicator
6. Driving mode
7. Mixed reality vehicle info
8. Traction battery capacity
9. Range
10. Range standard
11. Time information
12. External temperature information

Note: Card information includes fixed information and temporary information;

Fixed information includes: "Energy consumption", "Current Mileage", "Cumulative mileage", "Tyre pressure", "G value", and "Moment distribution of front and rear axles";

Temporary information includes: "Alarm card", "Distance adjustment", "Bluetooth phone" ..

Central screen display

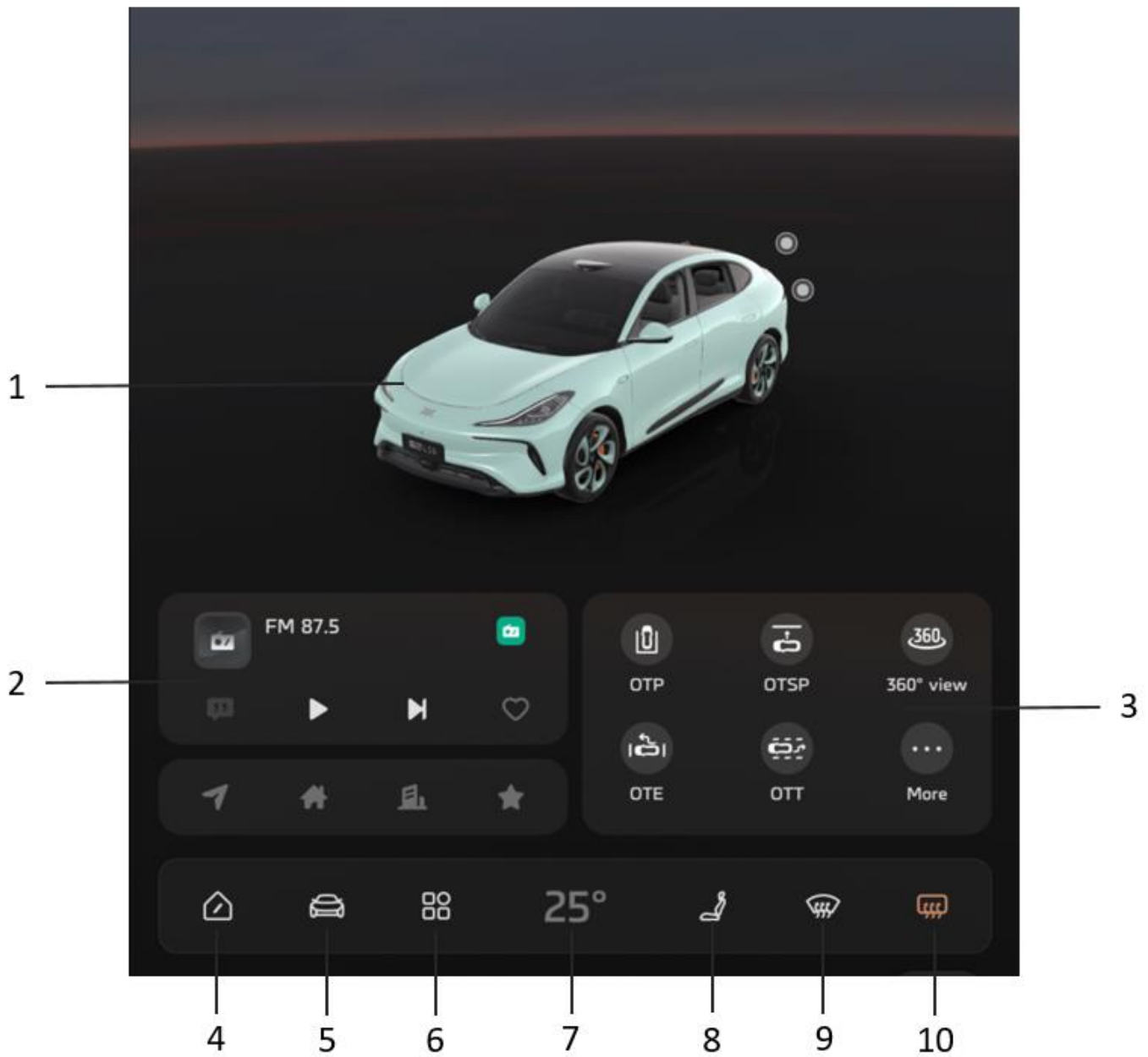

1. 3D vehicle model
2. Music
3. One Touch Parking/Side Parking/Escape/Traceback
4. Home button
5. Settings
6. App list
7. Air conditioning
8. Seat
9. Windscreen defogger
10. Rear windscreen defogger

Note: The user can slide right along the left edge of the central screen to enter the Quick Control Centre (including the buttons for Bluetooth, Digital Video Recorder, Lamp, Charging Door, Screen lift and other functions), and edit (including addition, deletion, sequence adjustment and saving) the Quick Control Centre by tapping the "Edit" button on the upper left or long pressing any function card. The user can swipe left on the screen or tap the blank space on the page to exit the Quick Control Centre.

App list

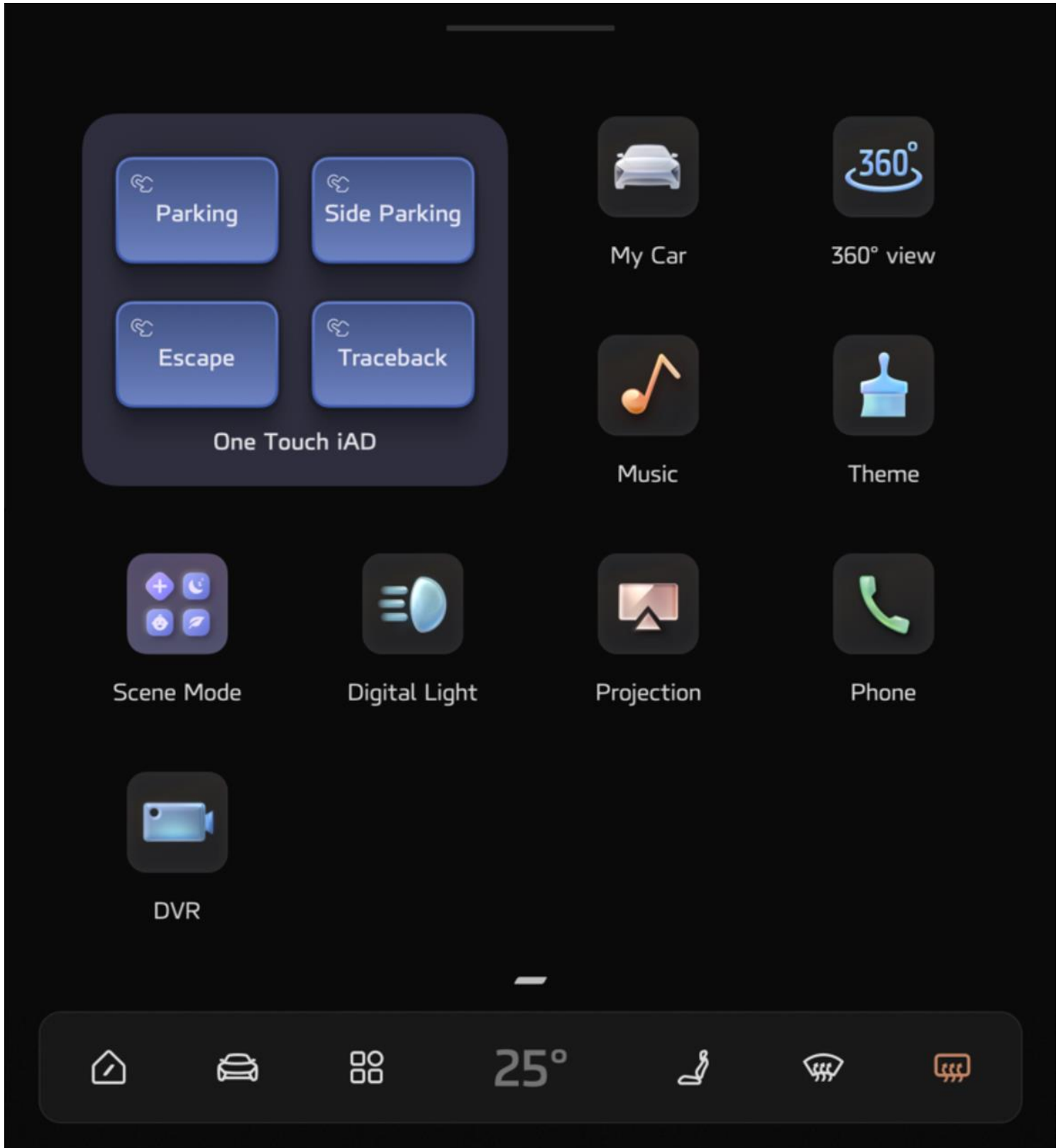

App list includes: One Touch Parking/Side Parking/Escape/Traceback, My Car, Around View Monitor, Music, Theme, Scene Mode, Digital Light, Projection, Phone, Digital Video Recorder (DVR).

Grab inwards with five fingers on the page of central screen to enter the app list;

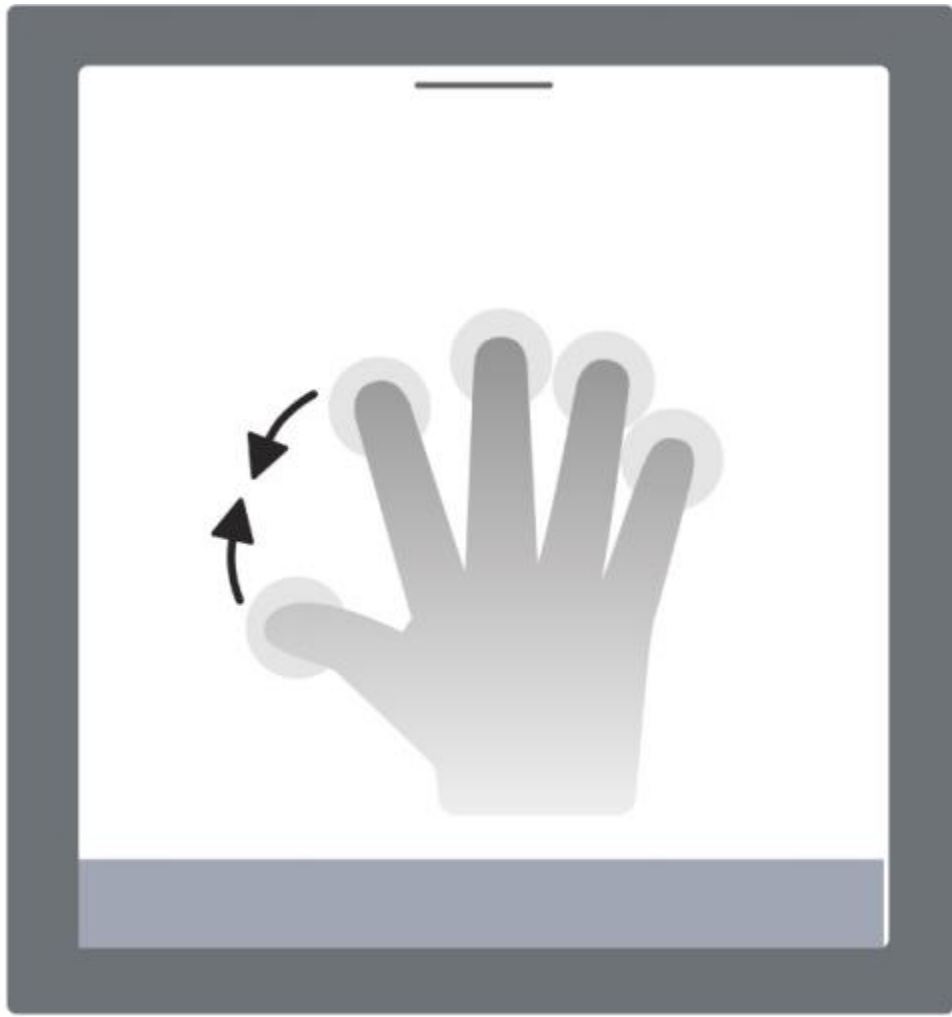

Swipe down with a single finger from the top horizontal line to exit the app list.

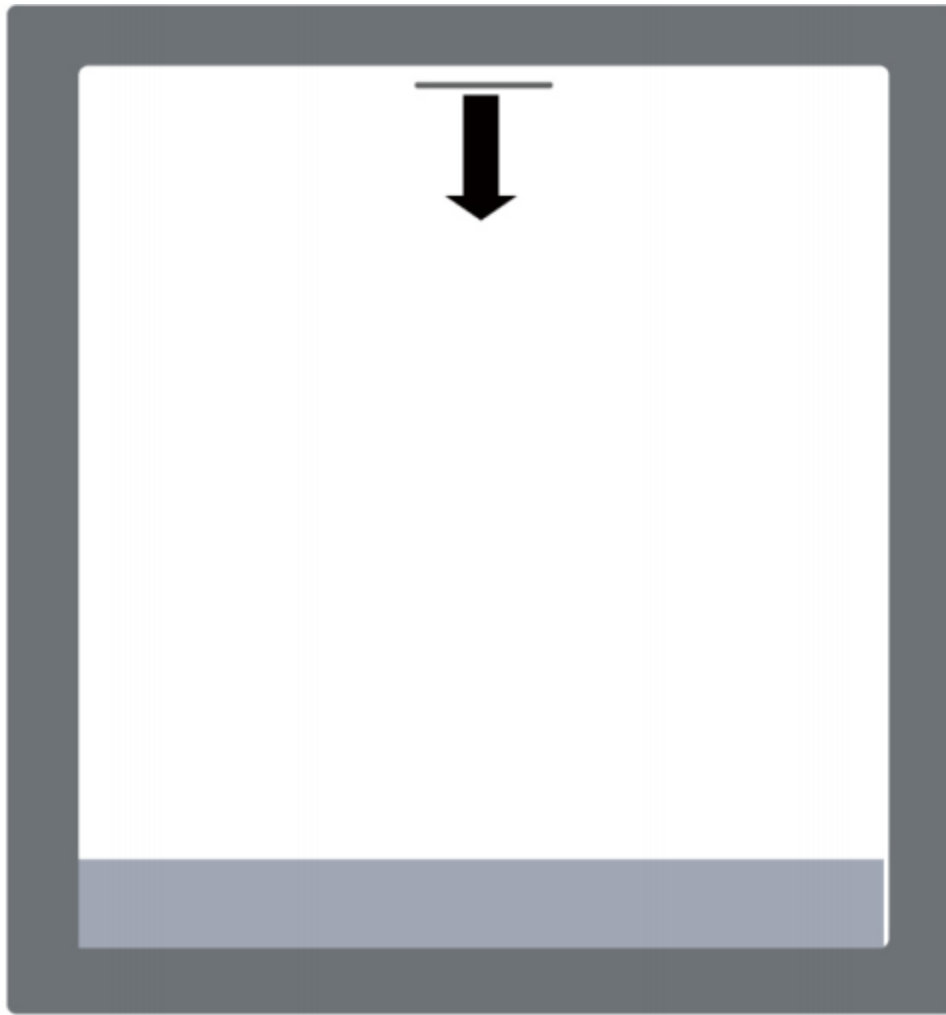

One Touch Parking/Side Parking/Escape/Traceback

Refer to “Shiftless Automatic Parking Assist System with Fusion (S-APA with Fusion)”, “One Touch Escape (OTE) ”, “One Touch Side Parking (OTSP) ” and “One Touch Traceback (OTT) ” in “Intelligent Drive System”.

My Car

My Car includes: vehicle charging, discharge, energy consumption, notification centre and other related information; refer to "Charging" for details.

1. Energy Consumption: includes the energy consumption curve.

Warning: If a DC charger has been inserted, it is prohibited to insert an AC charger, otherwise the vehicle may not be charged.

2. Charging capacity setting:

When the vehicle is not charged, go to "My Car" > "Charging Settings" and drag the setting button.

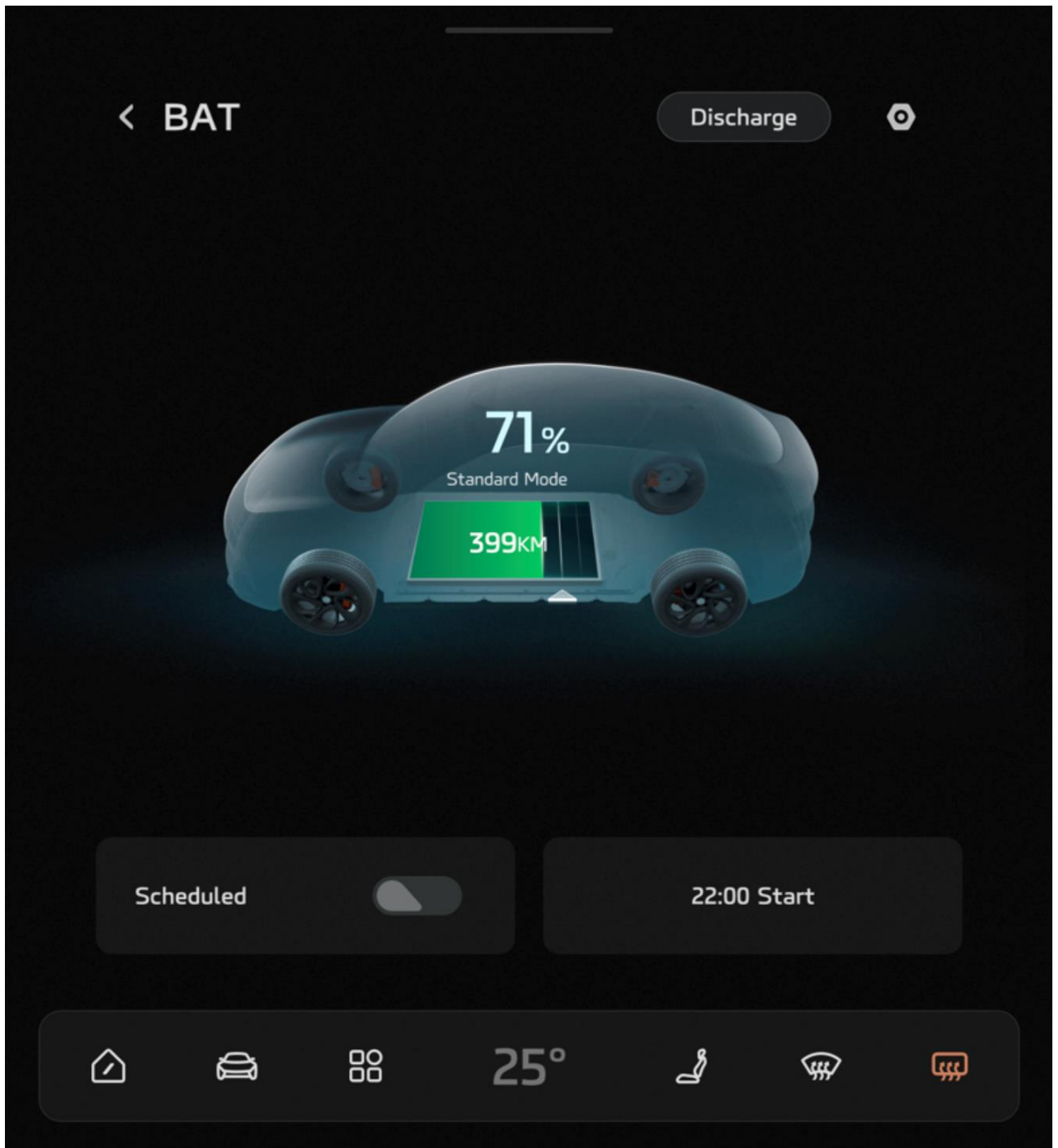

When the vehicle is being charged, tap the charging status under "3D vehicle model" to enter the charging page, and drag the setting button.

Note: The charging capacity setting has three positions; the charging limit has the power-off memory function if the user has set the charging limit. If the traction battery capacity is higher than the charging limit, the vehicle cannot be charged.

3. Discharge:

AC discharge enables the power stored in the traction battery to be output through the discharger at a voltage of 220 V and to be used by external electrical appliances.

After inserting the discharger, taps " Discharge ".

Note: The cut-off power of external discharge can be set by dragging, and the minimum cut-off power is 20%.

IMPORTANT

If the discharger has been inserted, it is prohibited to insert the charger again.

4. Settings: include the range standard, battery preheating before fast charging.
Note: The setting related interfaces are different depending on the configuration.

Around View Monitor

The user can tap the Around View Monitor to check the surroundings of the vehicle on the driver entertainment screen; refer to "360 Around View Monitor" for details.

The user can enter the Around View Monitor in the following ways: When the vehicle is powered on and the speed is less than 15km/h, tap the Around View Monitor in the app list on the central screen; or shift into R gear to enter the Around View Monitor; or press the custom Around View Monitor button on the steering wheel.

The user can exit the Around View Monitor in the following ways: Tap the "X" button on the page or press the home button; or the speed exceeds 15km/h while driving in D gear; the Around View Monitor automatically exits after shifting into P gear for 3 seconds; automatically exit after parking is completed.

Note: Tap to enter "Settings > General > Steering Wheel Buttons" on the central screen to set the custom Around View Monitor button on the steering wheel.

When the vehicle is in R gear or the intelligent parking system is enabled, the Around View Monitor cannot be turned off and the "X" button is hidden. The Around View Monitor cannot be turned off even by tapping the home button.

The front view and rear view buttons are hidden, which can be displayed by tapping the top view area of the Around View Monitor.

If there is an obstacle approaching the vehicle, the vehicle will display the radar wall information at each location in white, yellow or red depending on the distance.

Select the Settings button on the upper right of the top view of Around View Monitor, and select the related setting item. For example, Around View Monitor enabled at start-off, radar alarm tone, and Around View Monitor transparent chassis.

Warning: Please use the Around View Monitor function with caution while driving to avoid affecting driving safety.

Music

Tap to enter Music; refer to "Music" for details.

Scene Mode

Function presetting: nap mode, pet mode, etc.

Note: Nap mode: When the vehicle is in P gear and not in automatic parking condition, the energy range is higher than 70km or the vehicle is being charged, and the seat behind the driver seat is not occupied, the centre console will be locked, the seat will be adjusted to a comfortable angle, the windows will be closed, the notification audio will be muted, the air conditioning will be turned on, and the screens, sound, and atmosphere lamp will enter the nap mode.

When the driving range is too low, the vehicle will prompt to exit the nap mode.

Pet mode: When the user needs to put a pet in the vehicle, the pet mode can be turned on; the vehicle should be in P gear and not in automatic parking condition, the energy range is higher than 70km or the vehicle is being charged; at this time, the centre console will be locked, the windows will be closed, the air conditioning will be maintained, and the screens will enter the pet mode.

Note: When the driving range is too low, the vehicle will automatically exit the pet mode. At this time, the window will be opened by 5%.

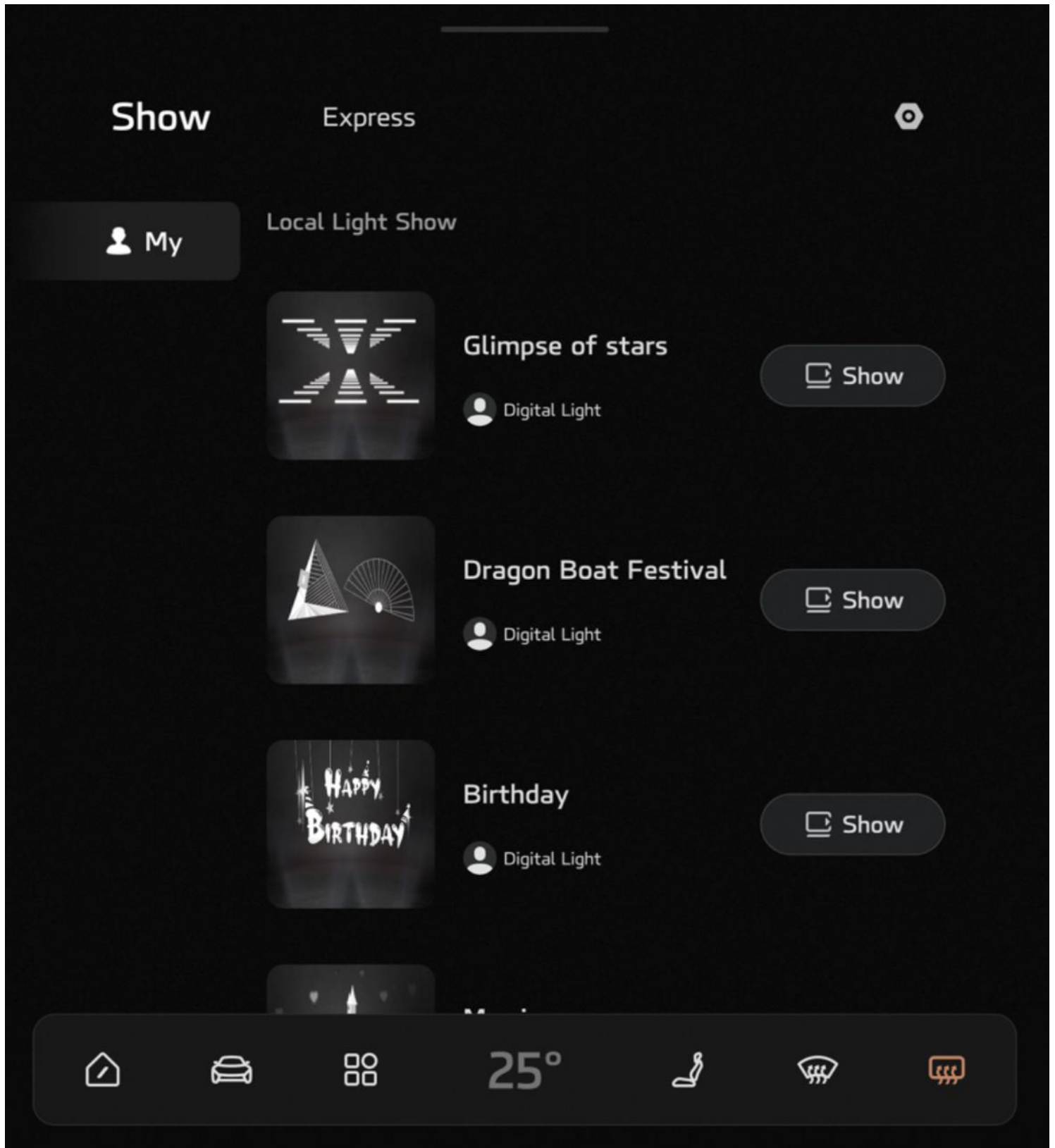

The user can use the light show function to play the prefabricated light show in the vehicle and trigger ISC rear lamps*, and the on-board speakers can play the light show at the same time.
The user can use the light expression function to express his/her emotion to the outside, and the ISC rear lamps * will display personalized icons to convey information and emotion to others.
Note: Some models do not have Digital Light Processing, which is subject to the actual vehicle status.

Phone

Tap to enter the Communication page; refer to "Communication" for details.

Digital Video Recorder

After tapping, the driver entertainment screen will display the real-time images; the central screen displays a list of recorded videos, which can be played back by tapping, and the settings can be selected on the upper right of the central screen; refer to "Digital Video Recorder" for details.

The setting items include: video recording switch, watermark, speed display, storage space and formatting.

The Edit button next to the Settings on the central screen can delete multiple videos.

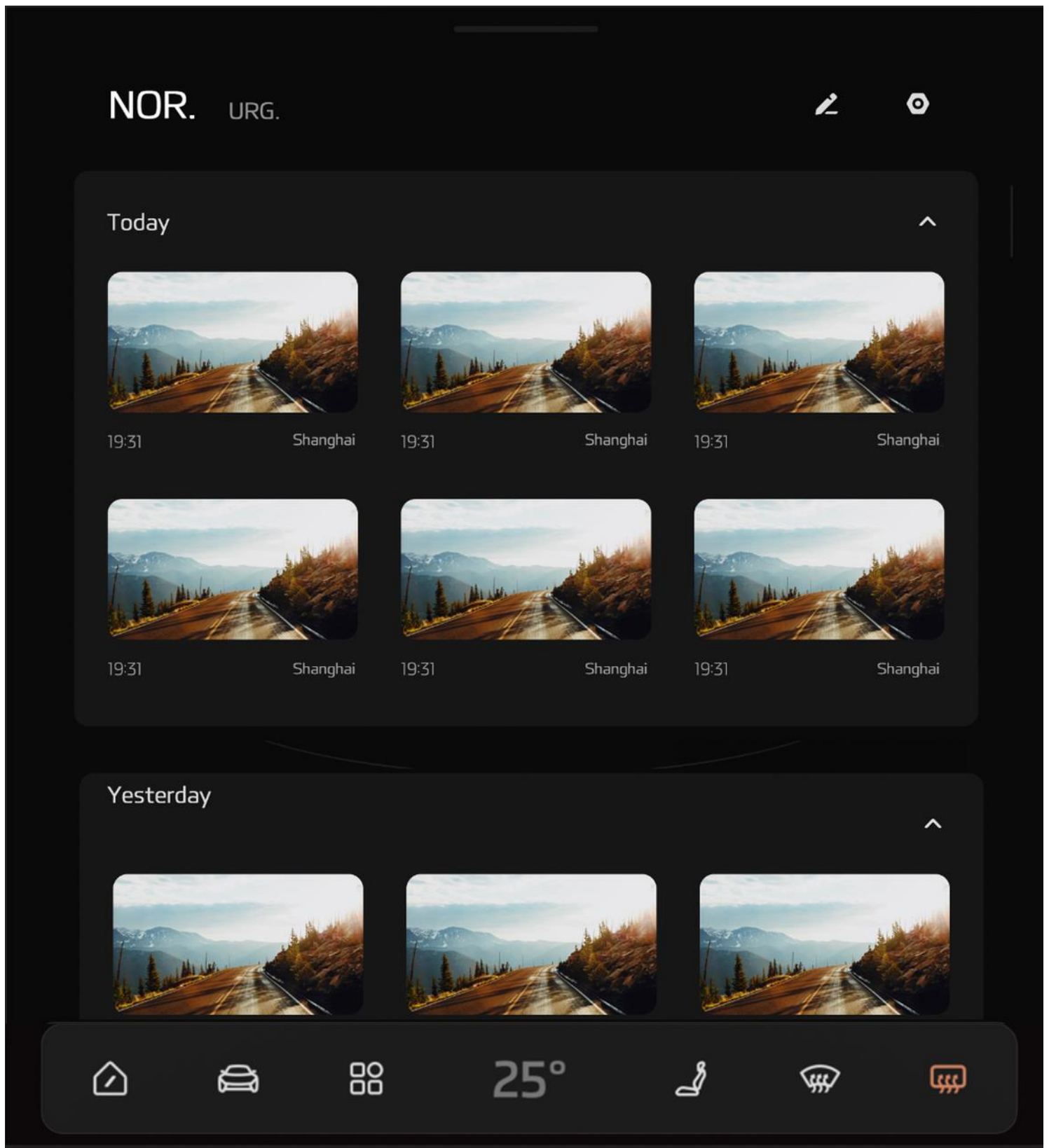

Note: The user can watch the recorded videos on the central screen; in case of emergency (AEB automatic emergency braking or airbag deployed), the video 3 seconds before and 9 seconds after the trigger condition will be cut out to form an emergency video and saved to local; 3-minute videos are recorded cyclically, and the earliest video will be overwritten after about 9 hours (SD card: 64G). The user can use an SD card with higher capacity, so that the overwriting time will be longer. If an SD card of less than 64GB is used, an prompt will be given that it cannot be used.

Vehicle Settings

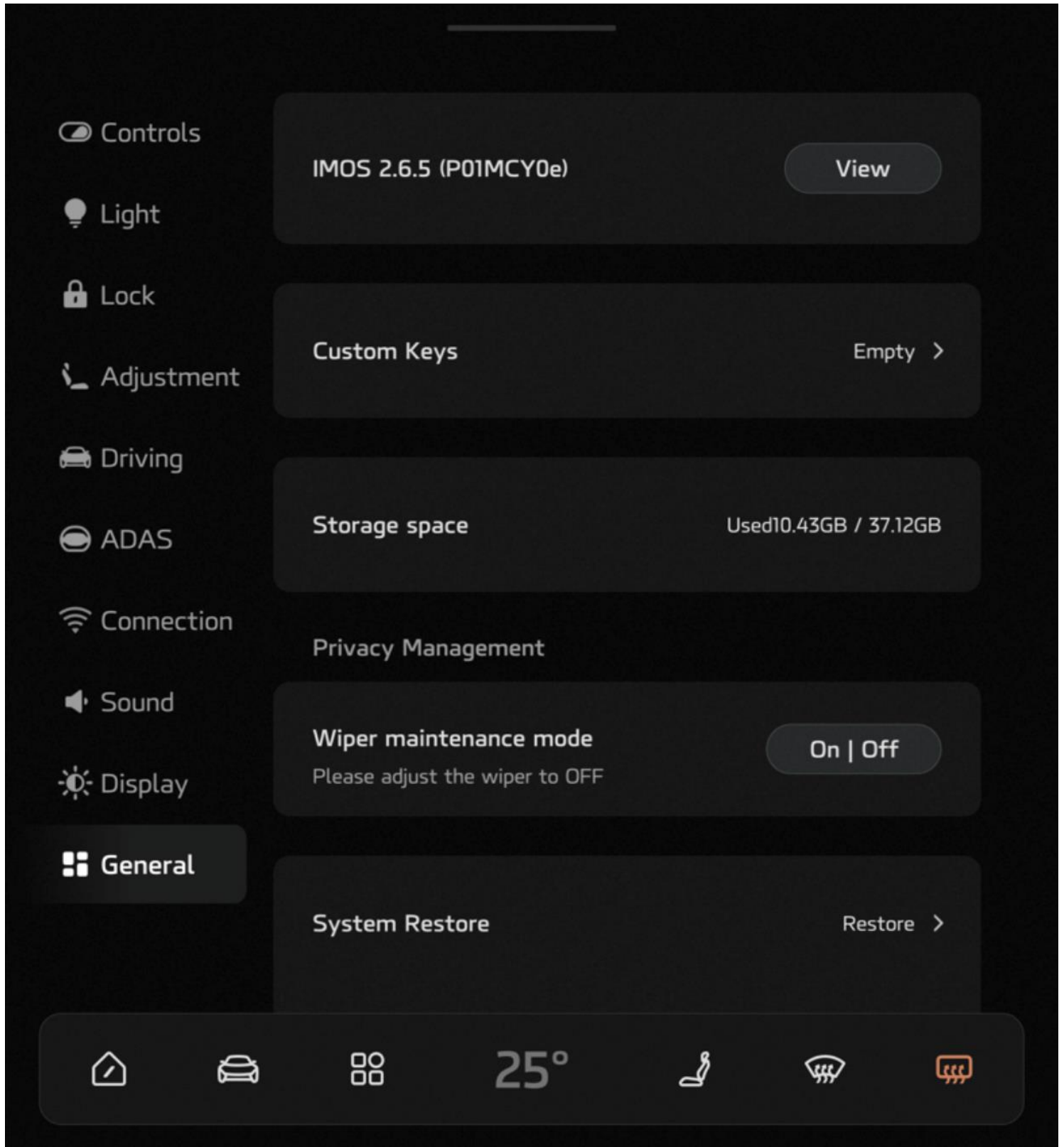

The settings include:

Controls (exterior lights, wiper Gear, rearview mirror adjustment, steering wheel adjustment, window, energy recovery level, body stabilization system switch, etc.); refer to "Exterior Lighting", "Energy Recovery during Coasting", "Steering Wheel Adjustment", etc. for details.

Light (ambient light, reading light, headlamp delay off and Height); refer to "Interior Lighting" for details.

Lock (window, child lock, tailgate height); refer to "Window", "Tailgate" and "Starting the Power System" for details.

Adjustment (driver position memory and convenient access); refer to "Seat" for details.

Driving (driving mode selection, super ECO, ESR, auto hold, HHC and body stabilization system); refer to "Shifting and Driving" and "Auto Hold" for details.

Note: When the Super ECO is enabled, it is recommended to drive at a speed not more than 60km/h, which can improve the driving range greatly. In this case, the limit on kinetic energy output is significant, and the ADAS, DVR, Surround View, S-APA with Fusion, BSD, Rear View Video, Daytime Running Lamp, A/C and Multimedia Application functions are disabled to reduce the brightness of driver screen, while the front passenger screen and central screen are off. After the Super Energy Saving is exited, ADAS, DVR, Surround View, Intelligent Parking and other functions will be restored in a short time, please wait patiently.

ADAS (full-speed ACC, Pilot, speed limit adjustment, image assist, speed limit warning, forward collision assist, rear collision assist and lane departure assist); refer to "Driver Assistance System" for details.

Connection (Bluetooth, wireless charging device forgetting reminder); refer to "Communication" for details.

Note: When the wireless charging function is disabled, the device forgetting reminder is also disabled.

Sound (IM sound Mixer, volume and tone); refer to "Smart Acoustic System" for details.

Display (brightness, theme, screen off, screen plot mode and time).

Note: The user can set the brightness or automatic adjustment of the Scene screen and Hub screen; set the appearance of the screen display; and set the time display. After clicking the Cleaning Mode, all screens are off; long press any screen 2s to exit. In D gear, the driver screen shall not be off; when the vehicle is engaged in D gear, the driver screen shall be on automatically.

General (system view, storage space, custom keys, wiper maintenance mode, storage space, system restore and vehicle power supply); refer to "Turn on/off Vehicle Power Supply" for details.

Central Screen Restart

If the central screen "crashes", the user can press the roller on the steering wheel at the same time for ten seconds to restart the central screen.



Full-width Steering Wheel: The user can press two rollers on the steering wheel at the same time for ten seconds to restart the central screen.



Instrument Pack

Displayed Information of Instrument Pack

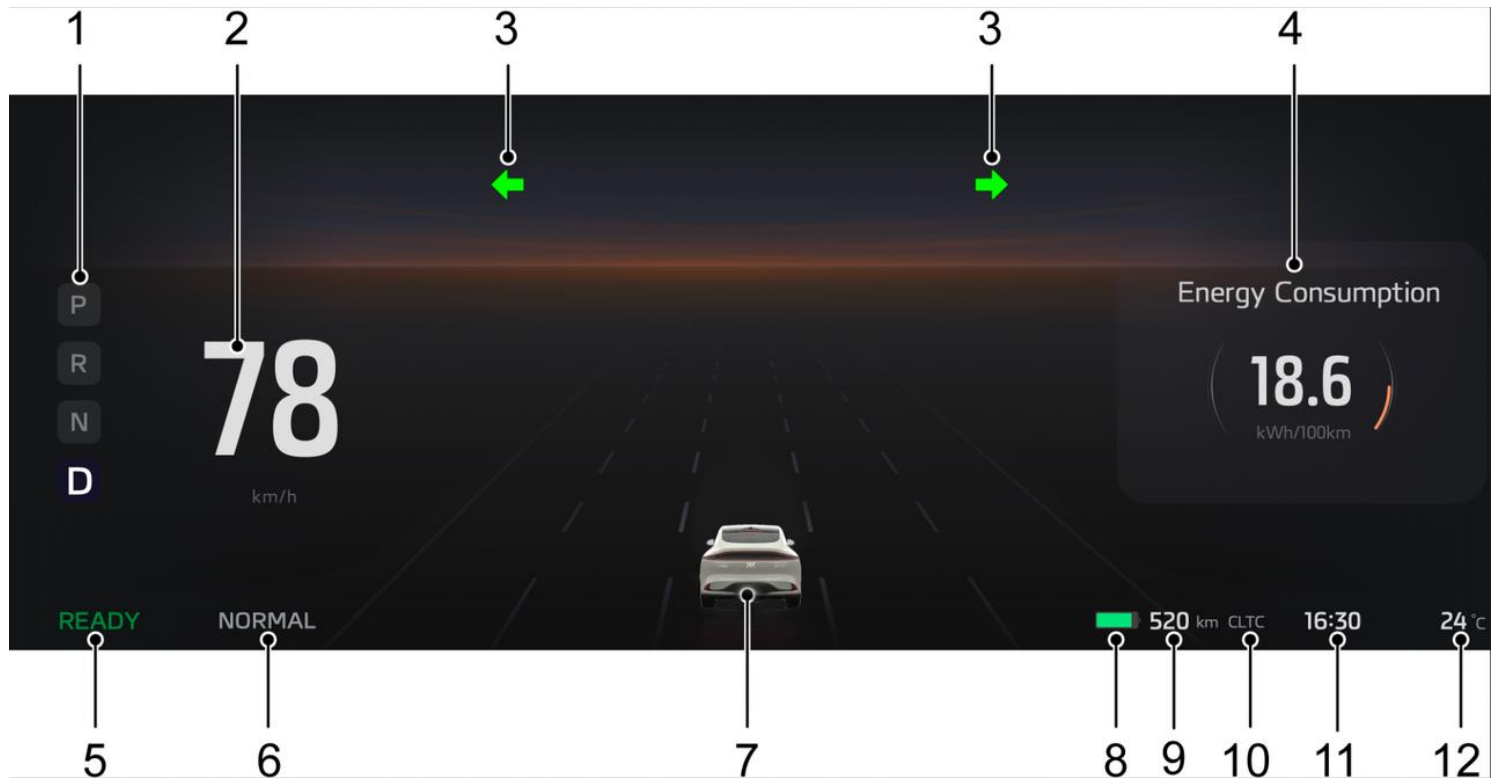

The instrument pack integrates the functions such as vehicle status monitoring, alarm, and intelligent drive. When using the vehicle, attention shall be paid to the information displayed on the instrument panel to obtain the real-time status of the vehicle.

1. Gear display
2. Vehicle speed display
3. Steering information
4. Card information area
5. System ready indicator
6. Driving mode
7. Mixed reality vehicle info
8. Traction battery capacity
9. Range
10. Range standard
11. Time information
12. External temperature information

Note: Due to changes in the settings, function usage, vehicle configuration, software version, etc., the illustrations are for reference only, which are subject to the actual vehicle.



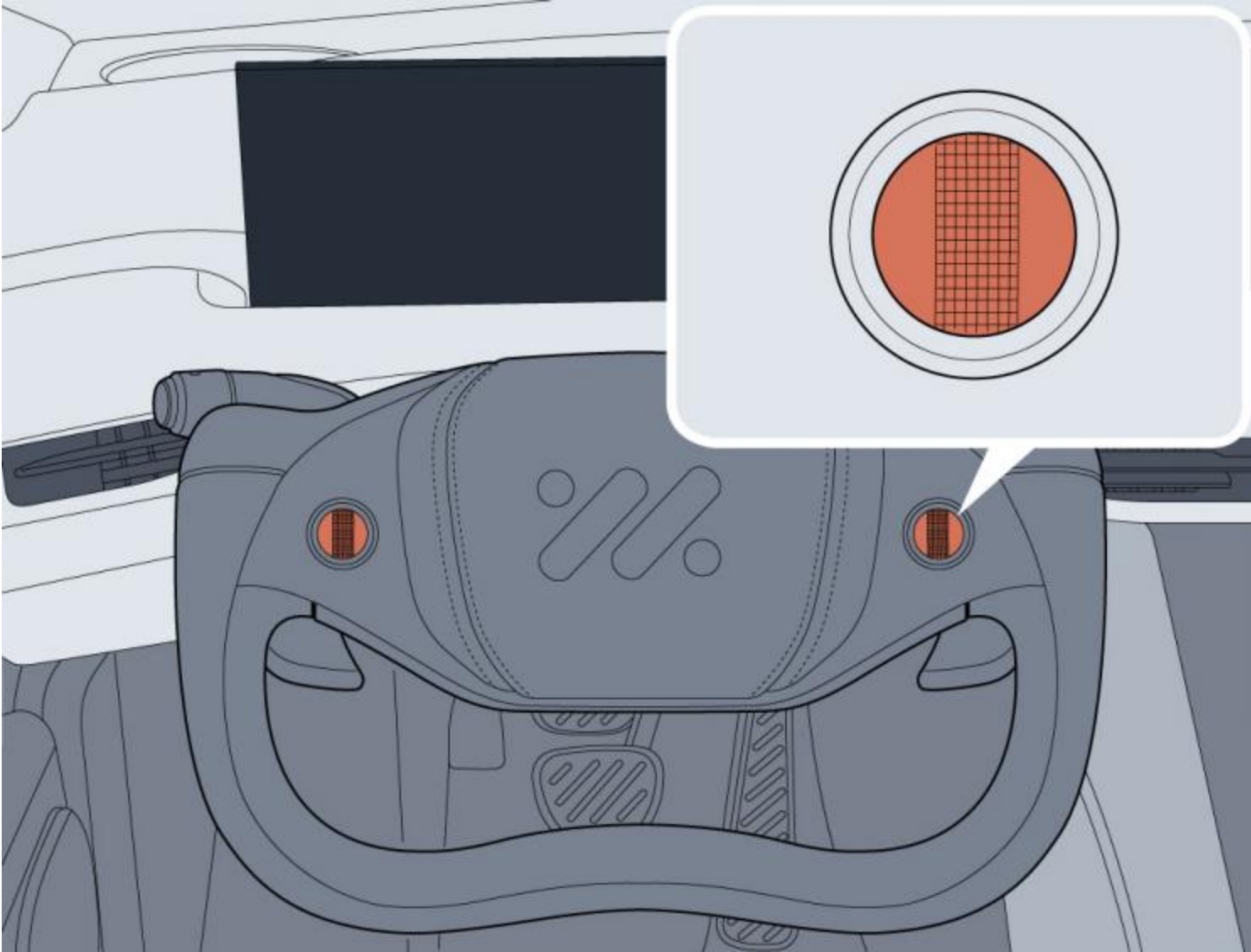

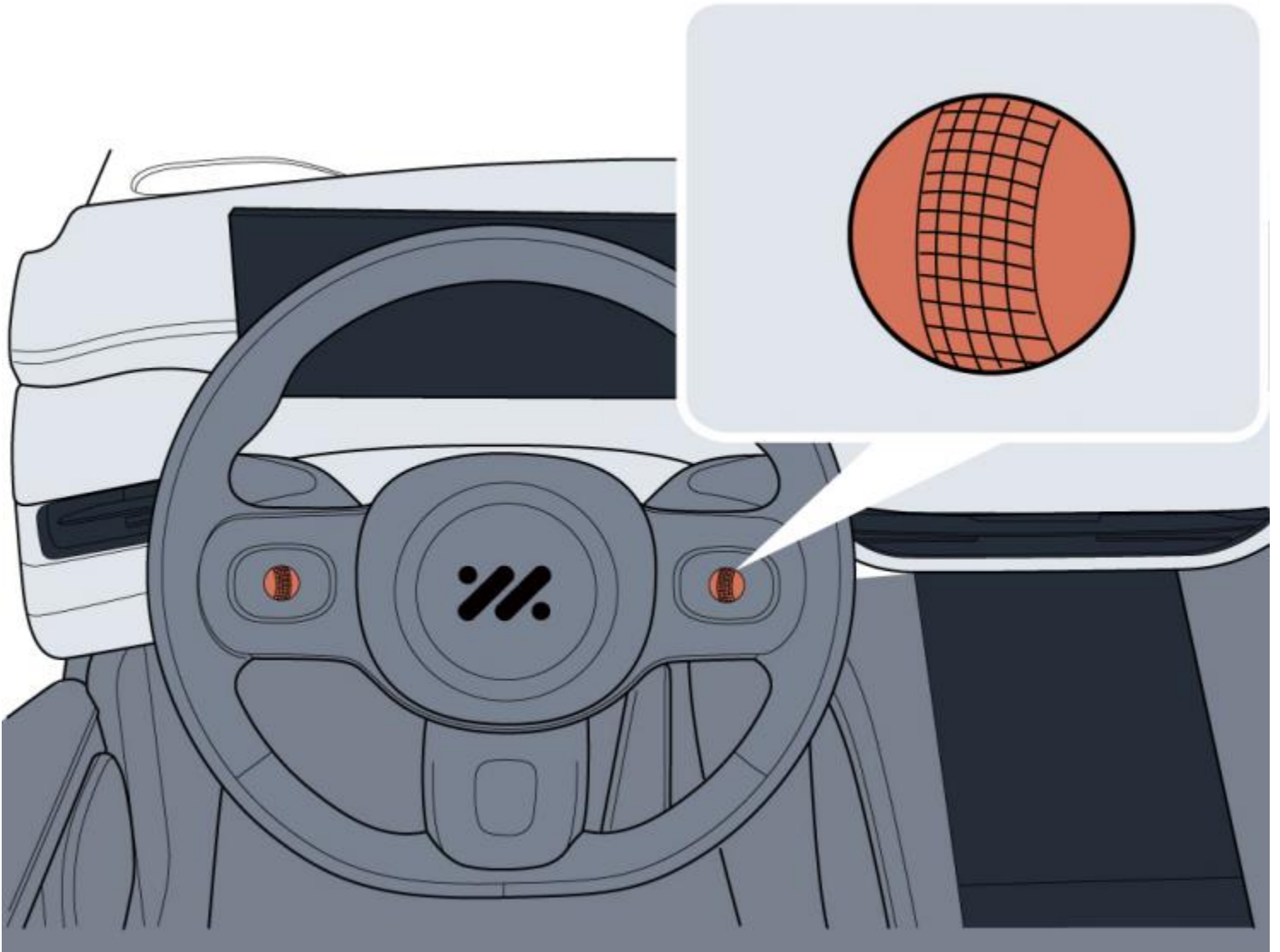







Displayed Information Switching









































1. Push the button to the left and right to switch the displayed information
2. Push the button downward to reset the trip computer
3. Short press the button to clear the alarm messages

Warning Lights and Indicators

Name	Icon	Description
Low Beam Indicator		Headlamp low beam is on.
High Beam Indicator		Headlamp high beam is on.
Rear Fog Lamp Indicator		Rear fog lamps are on.
End-outline Marker Indicator		Position lamps are on.
Direction Indicator Lamp		When the left or right turn signal lamp flashes, the direction indicator lamp on the corresponding side also flashes. If the hazard warning lamps are turned on, both direction indicator lamps will flash simultaneously.
Intelligent Headlamp Indicator		Intelligent high beams are on.
Anti-theft System Indicator		If this lamp illuminates, it indicates that no valid key is detected, in which case please use the correct key.
Front Seat Belt Unfastened Indicator		Driver/front passenger seat belt is not fastened.
Rear Seat Belt Unfastened Indicator		Rear left/middle/right seat belt is not fastened.
ABS Malfunction Indicator Lamp		Anti-lock brake system fails. If an ABS failure occurs while driving, the ABS function will be disabled while normal braking will still be available.
Brake System Fluid Level Low or Malfunction Indicator Lamp		If the brake system fluid level is low or the brake system fails, stop the car as soon as safety permits, and turn off the Start switch.
Electric Power Steering System (EPS) Warning Lamp		If this lamp illuminates, it indicates that the electric power steering system has a general failure related to the steering angle. Please stop the vehicle as soon as safety permits, restart the vehicle and drive for a while to the Authorised Repairer or contact the Authorised Repairer immediately. If this lamp flashes, it indicates that the electric power steering system has a serious failure, and is difficult in steering. Please stop the vehicle as soon as safety permits and contact the Authorised Repairer immediately.

		If this lamp illuminates, it indicates that the electric power steering system has a general failure. Please stop the vehicle as soon as safety permits, restart the vehicle and drive for a while to the Authorised Repairer or contact the Authorised Repairer immediately.
Dynamic Stability Control/Traction Control System Warning Lamp		If this lamp illuminates, it indicates that the dynamic stability control system/traction control system has failed. If this lamp flashes while driving, it indicates that the system is operating to assist the driver.
Dynamic Stability Control/Traction Control System OFF Warning Lamp		The dynamic stability control/traction control system is turned off
Hill Descent Control (HDC) ON/Malfunction Indicator Lamp		If this lamp illuminates, it indicates that the HDC function enters the Standby mode. If this lamp flashes, it indicates that the system is currently in the state of HDC function.
		If this lamp illuminates, it indicates that the HDC function fails. If this lamp flashes, it indicates that the HDC function is temporarily disabled.
Autohold Status Indicator		The Autohold system is operating to assist the driver.
		The Autohold system fails
4WD Status Indicator		4WD function is faulty, please contact a local Authorised Repairer for service as soon as possible.
Electronic Parking Brake System Status Indicator		If this lamp illuminates, it indicates that the EPB is enabled.
		If this lamp flashes, it indicates that the vehicle is parked on a slope with excessive angle or the electronic parking brake system failed, in which case please park the vehicle on the safe road surface.
Electric Parking Brake System Malfunction Indicator Lamp		If this lamp illuminates, it indicates that the electronic parking brake system has a failure. If this lamp flashes, it indicates that the electronic parking brake system is not calibrated.
Tyre Pressure Monitoring System Warning Lamp		If this lamp illuminates, it indicates that the tyre pressure is low. Please check the tyre pressure. If this lamp flashes and then remains ON after a period of time, it indicates the system has a failure.
Airbag Warning Lamp		Sensing and diagnostic module, airbag or seat belt fails

Low-voltage Battery Charging System Malfunction Indicator Lamp		<p>If this lamp illuminates after starting the vehicle, it indicates that the low-voltage battery charging system fails.</p> <p>If this lamp flashes, it indicates that the low-voltage battery is low, please start the vehicle as soon as possible.</p>
Power System Ready indicator		The vehicle power system is ready for running.
Charger/Discharger Indicator		The charger/discharger is connected.
Charging/Discharging Indicator		The vehicle is being charged.
		The vehicle is being discharged.
		It indicates charging/discharging failure.
Traction Battery Low Indicator		The battery is low. Charge the high-voltage battery pack as soon as possible.
Traction Battery Malfunction Indicator Lamp		The traction battery system is faulty. Please drive carefully to a nearby authorised repairer for inspection.
		<p>If this lamp illuminates, it indicates that the traction battery system has a serious failure. Please stop the vehicle safely for inspection.</p> <p>If this lamp flashes, it indicates the thermal runaway warning. Please stop the vehicle as soon as safety permits and leave the vehicle immediately.</p>
Motor Malfunction Indicator Lamp		If this lamp flashes, it indicates that the motor system has a serious failure. Please stop the vehicle as soon as safety permits and contact the Authorised Repairer immediately.
		If this lamp illuminates, it indicates that the motor system has a general failure. Please stop the vehicle as soon as safety permits, restart the vehicle and drive to the Authorised Repairer for a while or contact the Authorised Repairer immediately.
Power System Malfunction Indicator Lamp		The vehicle has a failure.
		The vehicle has a serious failure and its functions are restricted.
Drive Power Restricted Indicator		When this lamp illuminates, it indicates that the driving power is limited.
Lane Keeping System Indicator		The lane keeping function enters Standby mode.
		The lane keeping function is activated.

		The lane keeping function fails.
Lane Departure Warning System Indicator Lamp		The lane departure warning function enters Standby mode.
		The lane departure warning function is activated.
		The lane departure warning function fails.
Forward Collision Assist System Indicator		<p>If this lamp illuminates, it indicates any function of the forward collision assist system is disabled.</p> <p>When the functions of the forward collision assist system are fully enabled, if the lamp stays on, it indicates that forward collision assist system cannot work properly.</p>
Radar Malfunction Indicator Lamp		The rear driver assistance system is disabled, the radar is obscured or the system has a failure, and a corresponding prompt message will be displayed on the instrument pack.
Intelligent Drive System Malfunction Indicator Lamp		Intelligent drive system fails.
Driver Hands-off Indicator Lamp		Prompt the driver to immediately take over the steering wheel .

Warning Message

The top of instrument pack displays the warning messages. The warning messages are mainly classified into:

- Operation Instructions
- System State Prompts
- System Malfunction Alert

Please follow the text prompts or refer to relevant control system chapters for the failure cause and appropriate solutions.

The following are the fault messages which may appear on the instrument pack:

- Power Tailgate Failure, Please Schedule for Repair
- Front Left/Front Right/Rear Left/Rear Right Tyre Pressure Sensor Low Battery, Please Drive to the Authorised Repairer for Repair
- TPMS Failure, Please Drive to the Authorised Repairer for Repair
- Left/Right Low Beam Failure, Please Drive to the Authorised Repairer for Repair
- Rear Fog Lamp Failure, Please Schedule for Repair
- Reverse Lamp Failure, Please Drive to the Authorised Repairer for Repair
- Left/Right Brake Lamp Failure, Please Drive to the Authorised Repairer for Repair
- Front/Rear Position Lamp Failure, Please Schedule for Repair
- Left/Right Turn Signal Lamp Failure, Please Drive to the Authorised Repairer for Repair
- Daytime Running Lamp failure, Please Schedule for Repair
- Front Left/Front Right/Rear Left/Rear Right Tyre Pressure Insufficient, Please Stop and Contact the After-sales Repairer
- Front Left/Front Right/Rear Left/Rear Right Tyre Leaking Quickly, Please Stop and Contact the After-sales Repairer
- Front Tyre Pressure Unbalanced, Do Not Drive at High Speed, But Repair Immediately
- ABS Failure, Please Drive to the Authorised Repairer for Repair
- Body Stabilization System Failure, Please Drive to the Authorised Repairer for Repair
- Traction Control Failure, Please Drive to the Authorised Repairer for Repair
- Auto Hold Failure, Please Schedule for Repair
- HDC Failure, Please Repair
- Power Steering Failure, Please Stop and Contact the After-sales Repairer
- Steering Performance Reduction, Please Drive to the Authorised Repairer for Repair
- Steering Wheel Angle Sensor Failure, Please Drive to the Authorised Repairer for Repair
- Airbag Failure, Please Drive to the Authorised Repairer for Repair
- Vehicle Failure, Please Evacuate Vehicle Safely
- Driver Seat Occupancy Sensor Failure
- Power Mode Failure, Please Drive to the Authorised Repairer for Repair
- Low-voltage Battery Performance Reduction, Please Drive to the Authorised Repairer for Repair
- Low-voltage Battery Charging Failure, Please Drive to the Authorised Repairer for Repair
- Fast Charging Port Having High-voltage Risk, Please Stop Charging and Schedule for Repair
- Vehicle Failure, Please Evacuate Vehicle Safely
- System Failure, Please Schedule for Repair
- System Failure, Please Drive to the Authorised Repairer for Repair
- Vehicle Cannot Start After Flameout, Please Drive to the Authorised Repairer for Repair
- Motor Failure, Reverse Driving Not Supported, Please Drive to the Authorised Repairer for Repair
- Motor Failure, Please Drive to the Authorised Repairer for Repair
- Low-voltage Battery Charging Failure, Please Stop and Contact the After-sales Repairer
- P Gear Failure, Please Schedule for Repair
- Electric Drive Coolant Overheat, Please Stop and Drive after Cooling

Smart Acoustic System*

Volume Adjustment

The volume of vehicle media, broadcast, and communication can be adjusted and set through the steering wheel or the volume bar on the screen.

Volume Compensation with Speed

The vehicle has the function to automatically compensate and control the volume with the speed.

Central screen control: This function can be turned on or off in "Settings > Sound > Volume Compensation with Speed".

IM mixer*

IM vehicle is equipped with two sets of sound adjustment algorithm and sound effect system, 7.1.4 Dolby Atmos and 2.0 Stereo. The user can select either sound field mode and equalizer according to daily listening preferences, and the vehicle will intelligently match the corresponding 7.1.4 Dolby Atmos or 2.0 Stereo based on the current sound source, providing supreme acoustic effects.

The user can select to turn on or off the Dolby Atmos simulator switch based on personal listening preferences. If the Dolby Atmos simulator is activated, when the 2.0 Stereo songs or videos are played, the user can also experience the immersive auditory effect of 7.1.4 Dolby Atmos.

In Sound Settings, the sound field mode can be set, including: balance, Driver , Rear , Simulation* and Custom.

Equalizer

The user can select and customize the equalizer effect. It can be selected from three preset modes or customized. There are 16 adjustable horizontal segments, and each longitudinal segment supports an adjustment of ± 7 dB, which can be operated directly in the operation area, and all adjusted curves can be seen in the preview area. Two customization options support saving and name modification of custom parameters, and the Restore button can be tapped if curve restore is required during adjustment.

Central screen control: Different types of preset equalizer parameters can be selected or the equalizer can be customized in "Settings > Sound > Sound Effect > Equalizer".

Note: Some models have 10 adjustable horizontal segments, which are subject to the actual vehicle status.

Tone

The touch tone, notification tone and Lock tone can be turned on or off.

Central screen control: They can be turned on or off in "Settings > Sound > Tone".

Pedestrian Warning Tone

When the electric vehicles are driven at low speed in pure electric mode, the noise outside is significantly low. The pedestrian warning tone is equipped for driving at low speed, which is broadcast through the exterior speakers when the speed is 0-20km/h, and gradually decreases until it disappears when the speed is above 20km/h.

A/C

Ventilation



1. Front Face Side Vent
2. Windscreen Vent
3. Front Face Central Vent
4. Front Footwell Vent
5. Front Window Side Vent
6. Rear Face Vent
7. Rear Footwell Vent

The A/C system is used to adjust the temperature, speed, humidity and cleanness of the air inside the car. Fresh air is drawn in through the air intake grille under the windscreen and the A/C filter element. Always keep the air intake grille clear of obstructions such as leaves, snow or ice.

A/C Filter Element

The A/C filter element is used to filter the air. To remain fully effective, the filter element should be replaced at the recommended service interval.

Vent Adjustment

Rear Face Vent Adjustment

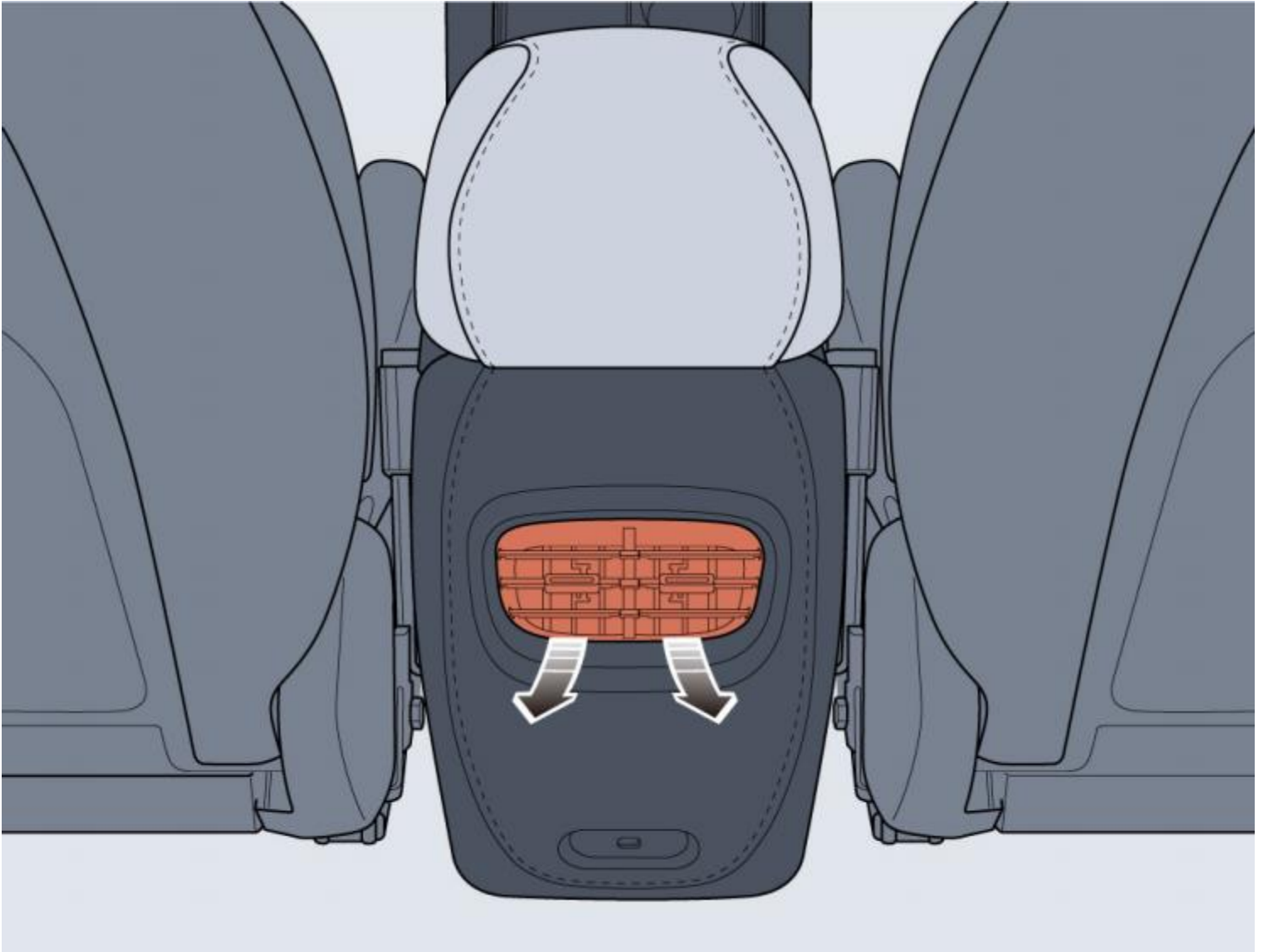

Slide the knob in the centre of the louvres from side to side to open or close the vent. Direct the air flow by moving the knob up and down, or from side to side.

Note: The front face vent can be operated in the central screen. Refer to the description in "Air Conditioning - Control Interface - Front Face Vent Adjustment" for details.

A/C Control Interface

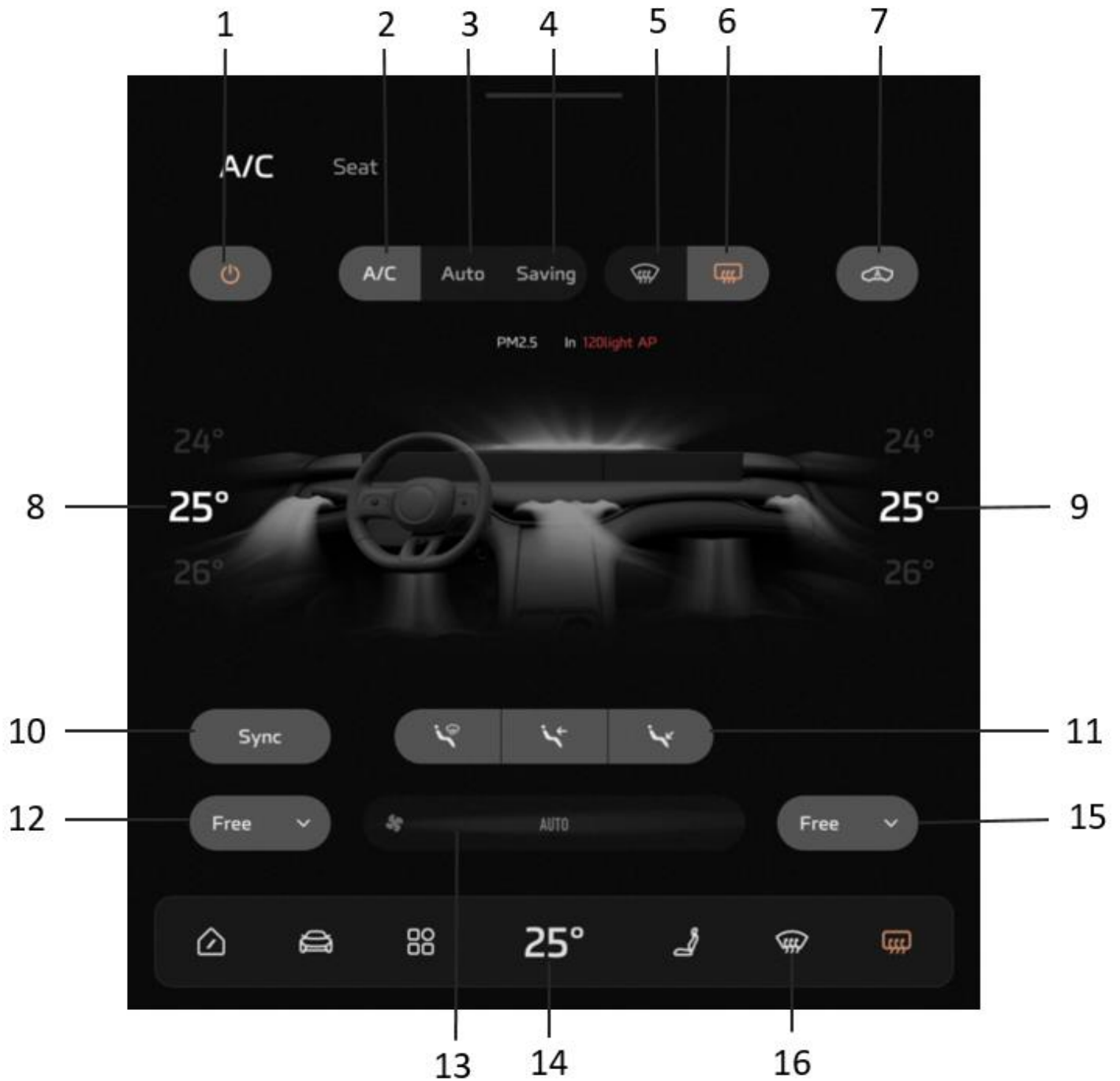

1. A/C System Switch
2. Cooling/Heating On/Off
3. Automatic Temperature Control Mode
4. Energy-saving Mode
5. Windscreen defogger
6. Heated Rear Window
7. Air Circulation Mode
8. Driver Temperature Control
9. Front Passenger Temperature Control
10. Synchronous Temperature Zone Control
11. Air Distribution Mode

12. Air Outlet Mode - Driver
13. Blower Rate Control
14. A/C Interface Display Button
15. Air Outlet Mode - Front Passenger
16. Heated Rear Window

A/C System Switch

Touch the A/C System On/Off Touch Button to turn on/off the A/C system.

Cooling/Heating On/Off

When touching the Cooling/Heating On/Off Touch Button, the A/C system will request to turn on the cooling/heating function.

Automatic Temperature Control Mode

When touching the automatic temperature control mode touch button to turn on the automatic temperature control function and setting the desired target temperature, the A/C system will automatically adjust the air distribution mode, blower rate, etc. to reach and maintain the set temperature.

Note: In order to ensure normal operation of the automatic temperature control function, all windows and sunroof should be closed, the air inlets should not be obstructed, and the automatic temperature control sensor should not be covered.

The vehicle will turn on the automatic mold prevention function of the air conditioning after the user leaves the vehicle according to the usage to avoid odor.

Energy-saving Mode

The air conditioning operates at low energy consumption in the energy-saving mode to extend the driving range, and the cooling/heating effect is reduced to a certain extent.

Air Circulation Mode

Touch the Air Circulation Mode Touch Button to switch the air circulation modes.

Note: Continuous internal circulation may cause the windshield to fog up. If this happens, turn on the defrost/demist function.

Temperature Control

Touch the driver/front passenger temperature selection icon to adjust the vent air temperature.

Synchronous Temperature Control

When touching the Synchronous Temperature Control Touch Button, the touch button illuminates, and the driver and front passenger temperature can be adjusted synchronously by the driver. When the touch button extinguishes, the driver and front passenger temperature can be adjusted separately.

Ventilation Mode

When the air distribution mode is selected as "To Face", different ventilation mode can be selected for the driver and front passenger to control the blowing direction of the vent on the corresponding side.

Note: In this mode, the vents at the driver and front passenger cannot be turned off at the same time.

Front Face Blowing Direction Adjustment

The vent airflow icon can be dragged to adjust the blowing direction.

Ventilation Mode

To "Windscreen": direct air to the windscreen and front window side vents;

To "Face": direct air to the face vents;

To "Footwell": direct air to the footwell vents;

Note: When manually selecting the ventilation mode to multiple modes, three modes can be selected for use; in the automatic temperature control mode, the A/C system will automatically assign the ventilation mode, and the ventilation mode on the A/C interface will be grayed out.

Blower Rate Control

Touch the blower rate control icon to adjust the A/C air volume.

Defrost/Demist

Press the Defrost/Demist Button, the Cooling/Heating On/Off will illuminate, and the system will enable Defrost/Demist function to clear the mist or frost on the windshield and front windows.

Pressing the Defrost/Demist button again will exit the defrost/demist function, and the system will return to the previous state.

In the defrost/demist mode, operation of air distribution mode will quit the defrost/demist mode.

Heated Rear Window

Warning: The heating element of the rear window is a sensitive component, and can be easily damaged when used improperly. DO NOT scrape or scratch the inside of the glass. DO NOT stick labels over the heating elements.

Press the heated rear window button to turn on or off the heated rear window function. It is on when the button indicator illuminates and off when the button indicator goes out. The heated rear window function will be automatically turned off after running for a certain period of time.

Description of Shortcut Operations

1. Swipe up or down with two fingers on any interface of the central screen to adjust the temperature.

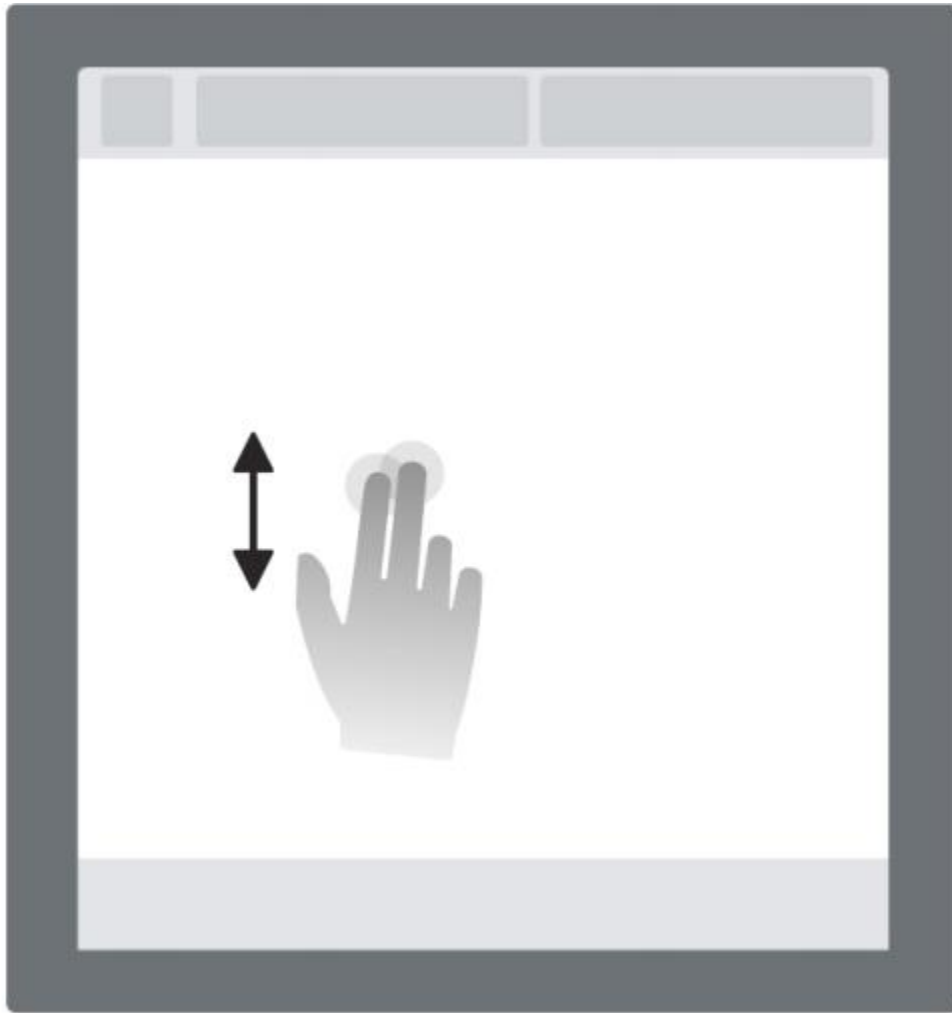

Note: The shortcut operation is only for the driver vents.

2. Swipe left or right with two fingers on any interface of the central screen to adjust the blower rate.

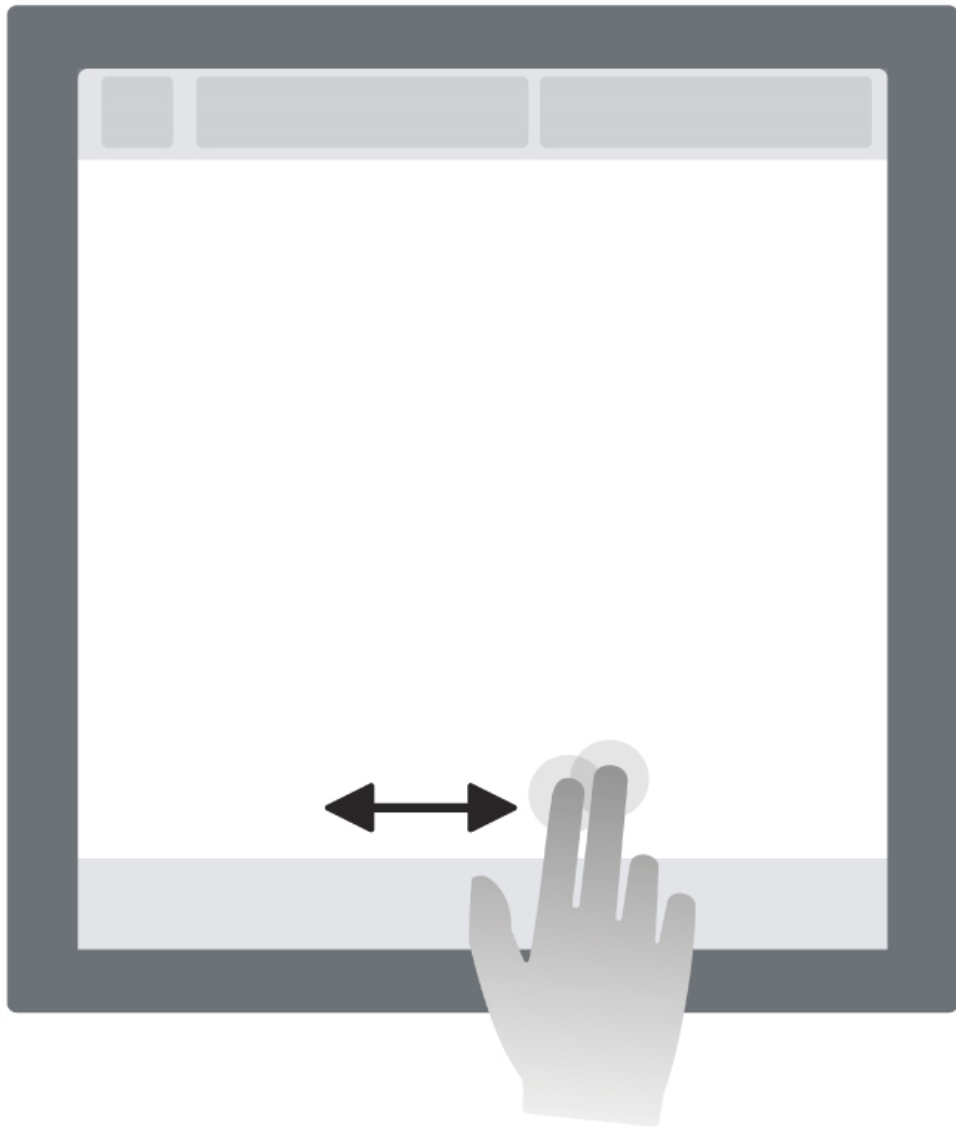

Note: The shortcut operation is only for the driver vents.

Music

Music

In “Music” APP on the central screen, you can click the module name on the page to switch between different types of audios.

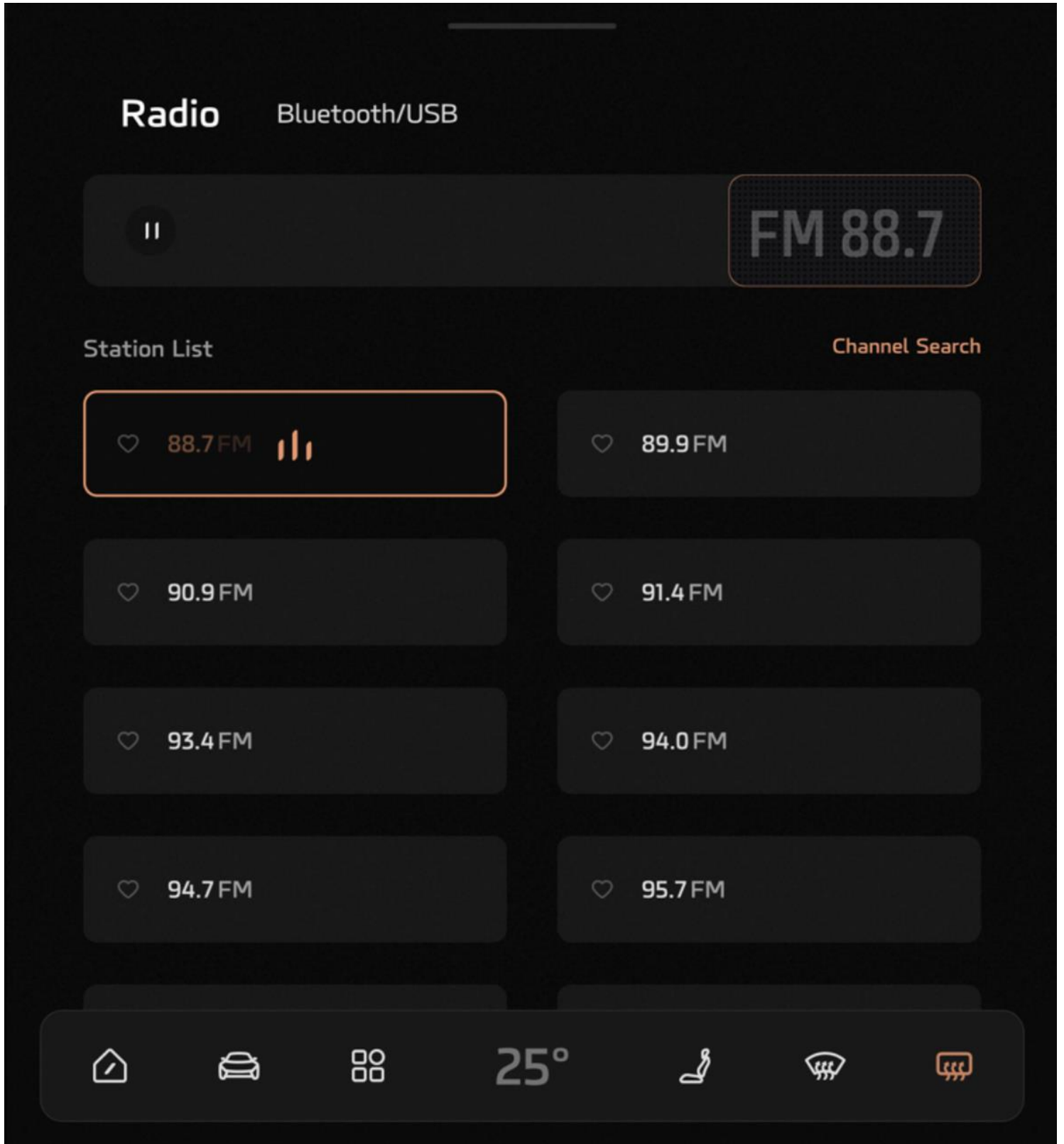

Note: Bluetooth/USB Music includes: Bluetooth music and USB music; Bluetooth music can play the music in the mobile phone by connecting to the mobile phone Bluetooth, with up to two Bluetooth mobile phones supported at the same time; USB music can play the music in the USB by inserting a USB, with up to two USBs supported at the same time. Click on the relevant radio channel to listen to relevant messages.

When you click “Please Connect Bluetooth” button, the Bluetooth Connection page will pop up automatically. After successful connection, the mobile phone’s name will be displayed, and you can select and play the music from the mobile phone; when two Bluetooth mobile phones are connected, you can switch between the play sources by clicking the different Bluetooth device icons.

After you insert the USB, the USB icon will display the name corresponding to the USB, and directly play the music in the USB; you can click the USB icon to enter and view the folders and select desired songs; when two USBs are connected at the same time, you can switch between the play sources by clicking the different USB icons.

You can use the buttons on the left of the steering wheel, or use the following operations: pressing the Up button, pressing the Down button, pressing the Middle button, pressing the Left button and pressing the Right button to enable the functions of increasing volume, decreasing volume, pause, previous and next.

Playing Operation of Music Player

1. When the user clicks or swipes left the small card, the small card will change into large card; the large card is in the following style.
2. General operation buttons of player: Play/Pause, Previous/Next, Play Mode (single cycle, random play, sequential play).
3. When operating the music player, the user can share by crossing the driver entertainment screen and passenger screen by swiping the relevant APPs with two fingers.

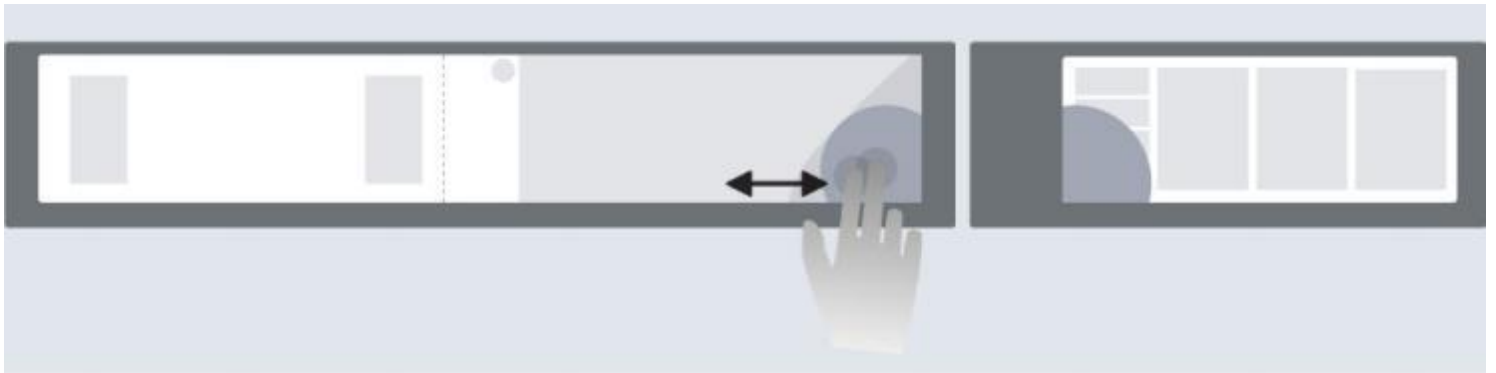

Phone

Bluetooth Settings

The user can connect mobile devices (such as mobile phones, BT) with the vehicle through the interior Bluetooth, and can choose to synchronize mobile phone data (such as contacts, call history) to the vehicle on the central screen, in order to better experience the on-board phone function.

Open "Settings > Connection > Bluetooth" on the central screen, and search for nearby available devices; locate the target device and click Connect.

Note: For Bluetooth devices paired for the first time, please check whether the pairing code on the mobile phone is consistent with the head unit, and then click "Pair".

Each vehicle can pair with 2 Bluetooth mobile phones and 1 BT. The user can view the Bluetooth connection on the driver entertainment screen.

Bluetooth Phone

1. After the mobile phone Bluetooth is successfully paired and connected with the vehicle Bluetooth, open the "APP List > Phone" on the central screen; Upon authorization by the user, the contacts, call history and other data will be synchronized to the vehicle. You can make a call by tapping a contact, call history, or entering a number on the dial.



2. When a phone card is displayed on the instrument pack, the user can follow the prompts on the card to press the "Left", "Right" and "OK" buttons on the right of the steering wheel to hang up, answer, or answer a new call.

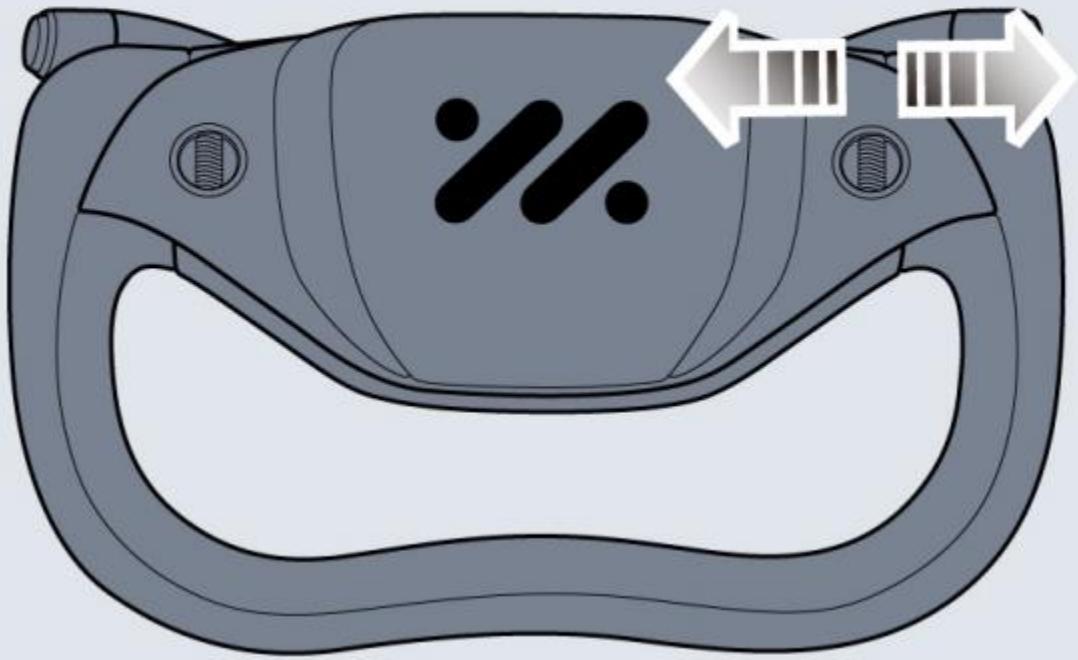

3. For full-width steering wheel, the user can press the "Left", "Right" and "OK" buttons on the right of the steering wheel to hang up, answer, or answer a new call.

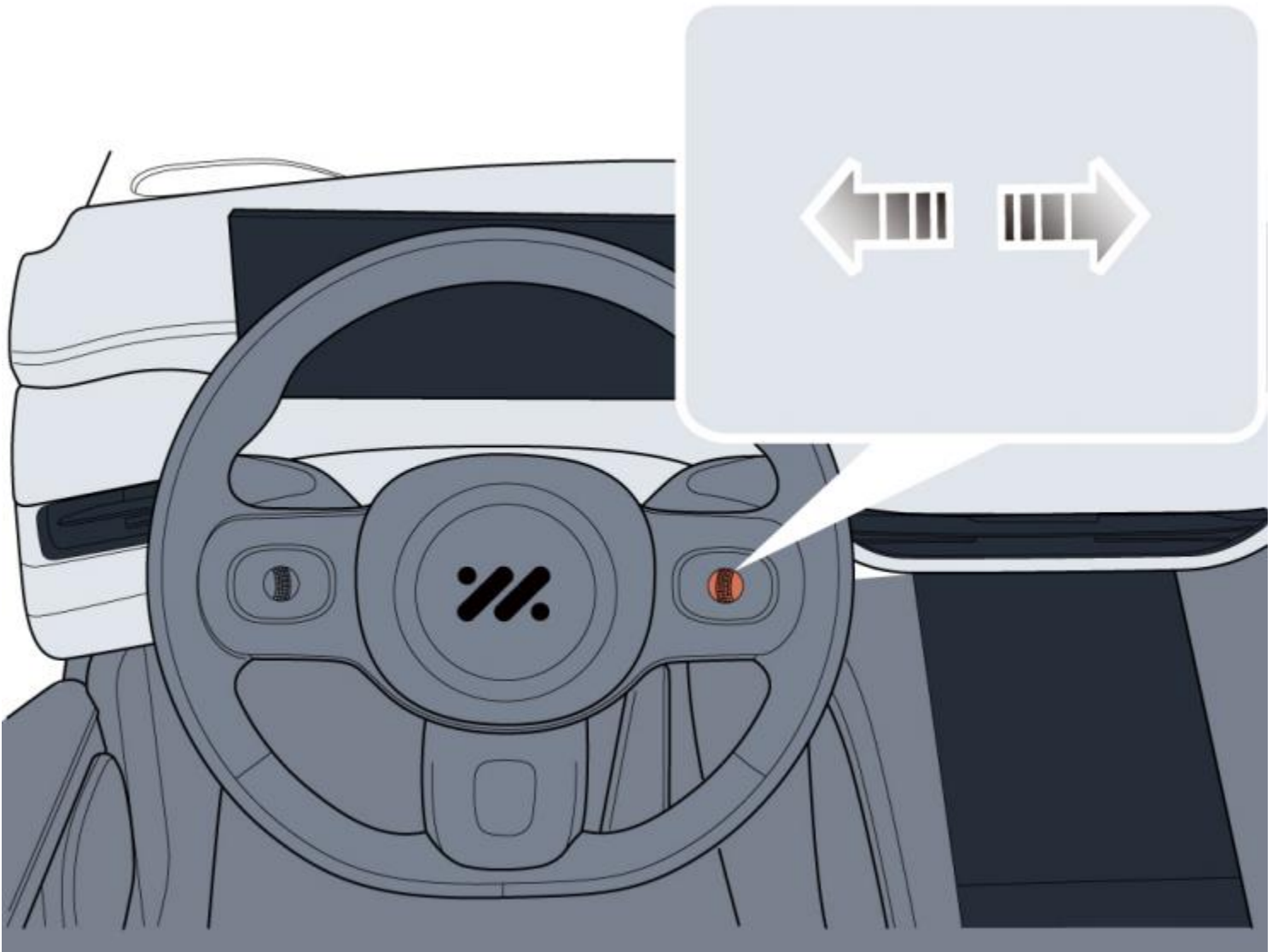

Note: During the Bluetooth call, you can click or swipe the green water drop right on the left of the central screen to open the call interface, and use the functions of sound zone switching, dial, microphone mute and hang up in the car.

Safe Driving

Charging

Charging Requirements

Generally, slow charging is recommended for the vehicle; frequent use of fast charging should be avoided. When the charging pile breaks down, immediately notify the relevant professional, and the operator cannot handle it without authorisation.

Before charging

Check whether the state of socket, jack and wire is good or not before charging.

It is recommended that the charging connector should be connected to the charging socket in the body before operating the charging device.

During charging

During charging, it is not allowed to start the vehicle. Charging operation time will be affected by external temperature. For example: charging time will be extended at low temperatures.

Charging can be conducted in rainy days, but rainproof measures will be adopted for charging connector and charging port in the process of removing and inserting charging connector. Charging operation should be stopped in extreme weather such as storm.

Spark may be generated in some modules of charging equipment. To avoid accident, do not conduct charging operation in gas station and places where there are inflammable gases or liquid.

During charging operation, the operation area may have magnetic field interference. It is recommended that users who carry implantable heart pacemaker and implantable angiocardy defibrillator keep away from vehicles under charging.

After charging

After charging, turn off the charging device first, then disconnect the charging connector from the vehicle body, and close the charging port cap (if equipped) and the charging port door on the body.

Charging Port

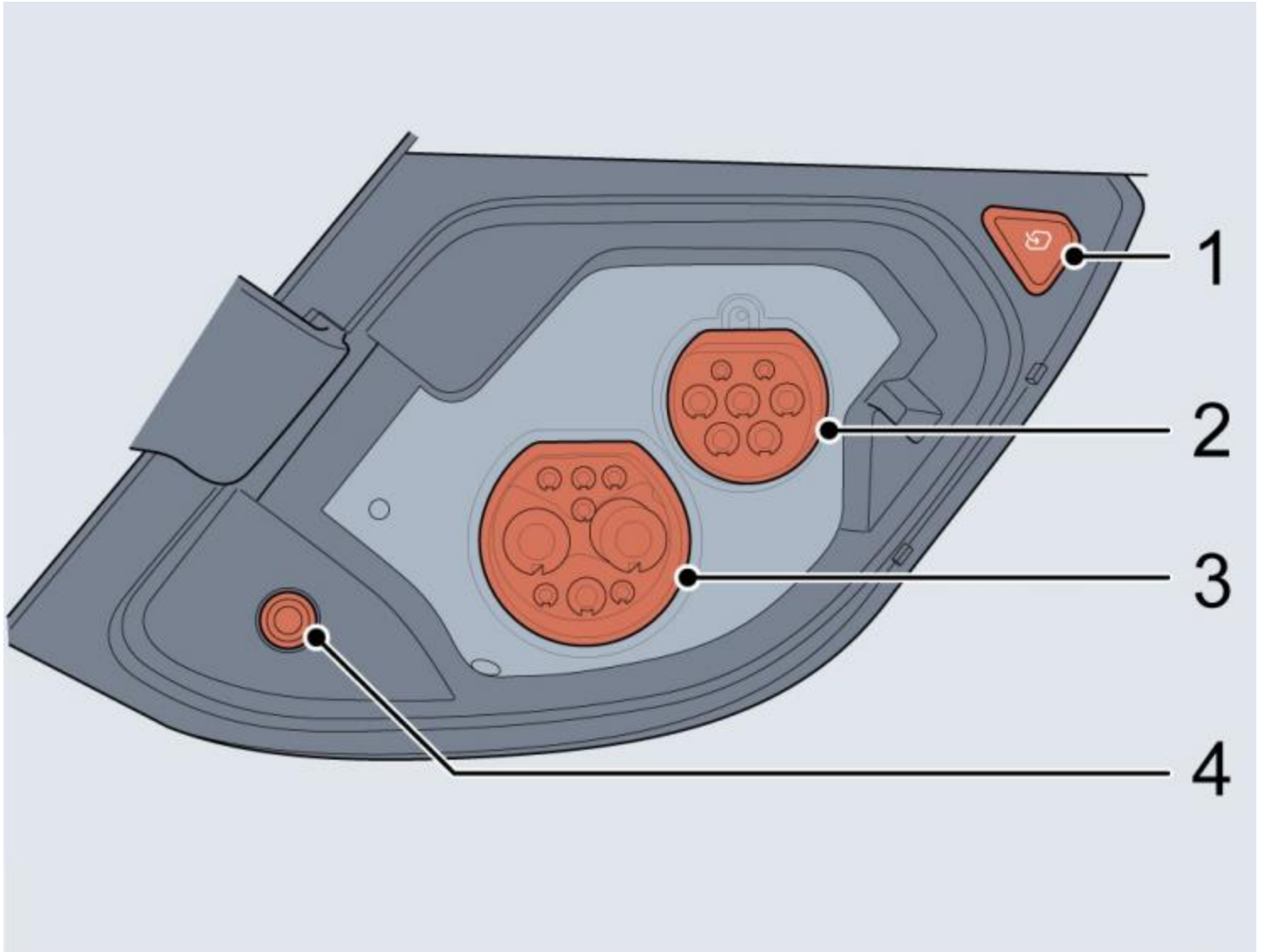

1. Charging port door switch

2. Slow charging port

3. Fast charging port

4. Charging state indicator

- White - Welcome
- Blue - Charging connection in place
- Orange - Charging connection not in place
- Green - Charging normal
- Red - Charging failure

Note: When the vehicle discharges externally, the indicator is in blue breathing state.

The fast charging port of some models is equipped with waterproof cover, which is subject to the actual vehicle status.

Open charging port door

The charging port door is on the rear left of the vehicle, and can be opened using any of the following methods:

1. When the vehicle is unlocked, if the user presses the upper right area of the charging port door (as shown in the figure below), the charging port door will automatically open;

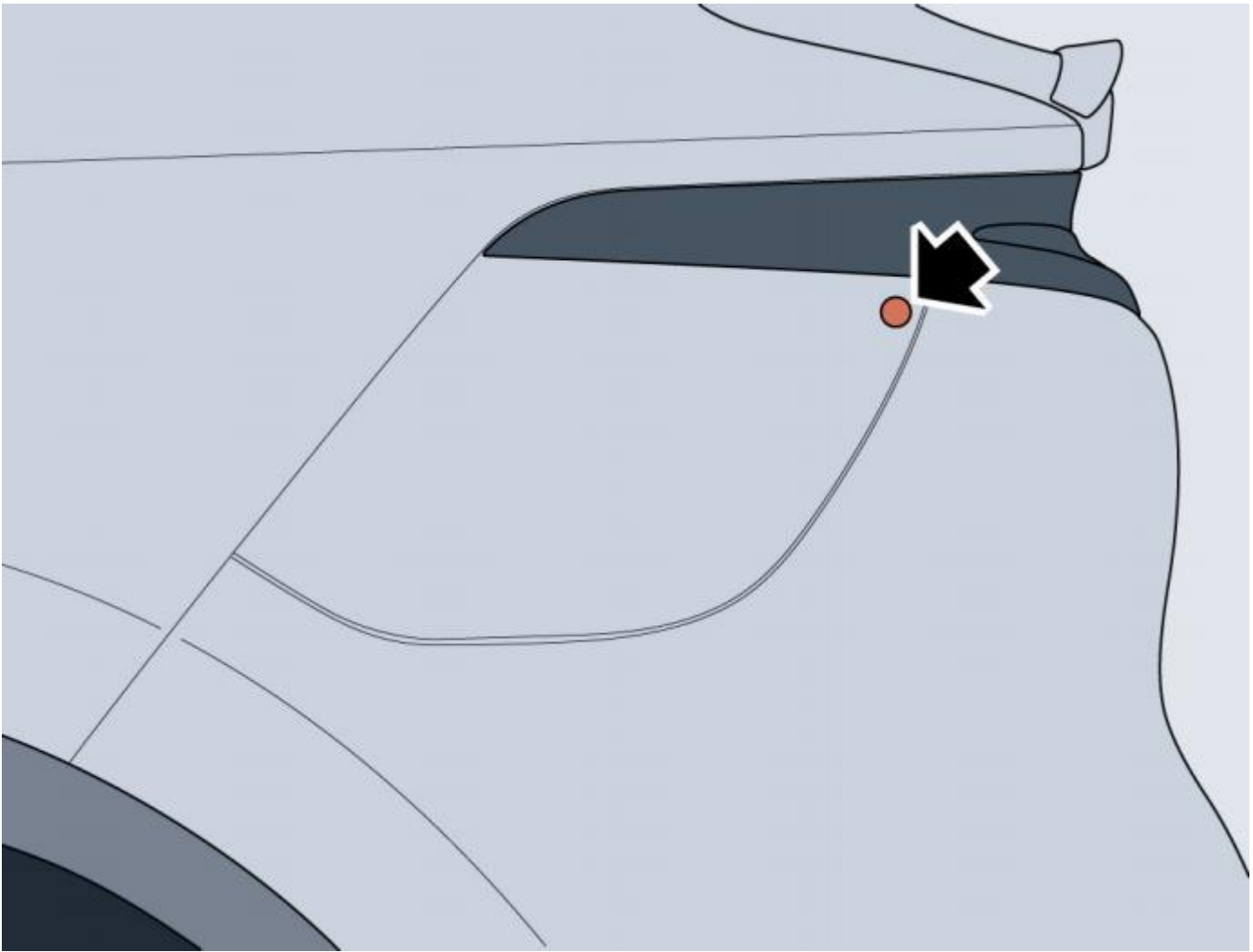

2. The charging port door can be opened when the charging port door on the 3D model of the vehicle on the central screen is operated. When the charging port door is open, the slow charging port and fast charging port are visible.

Note: If the charging port door is frozen and cannot open automatically, it needs to manually break the ice or open the door after the ice melts. Do not attempt to open the door using force, this will cause damage.

Note: Do not wash with the charging port door open.

Note: When the battery is low or disconnected, do not frequently open and close the charging port door manually to avoid damaging the internal mechanism.

Note: The 400V vehicle charging port is provided with a waterproof cover. Please install the waterproof cover in place after the completion of charge.

Charging port door opening in emergency

With the vehicle unlocked, if the charging port door cannot be opened normally when it is pressed, you can open it by pulling the open cable. Open the access port on the left trunk trim panel to expose the open cable of charging port door (pull ring - orange).

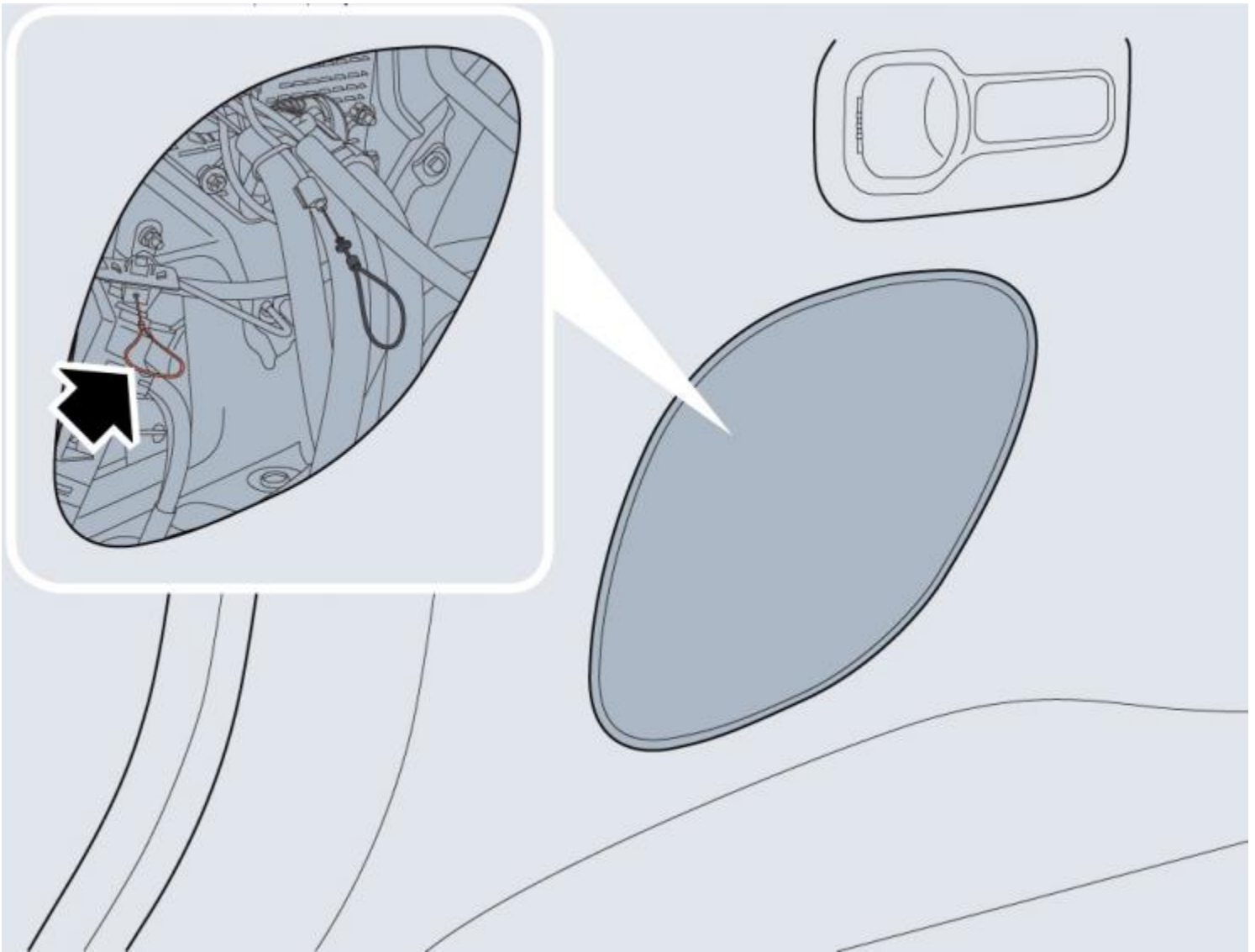

Close charging port door

After charging, the charging port door can be closed using one of the following methods:

1. After charging, pull out the AC charging gun, and the charging port door will automatically close;
2. When the vehicle is in READY state, and the charging gun is not connected, the charging port door will automatically close;
3. Press the charging port door switch, and the charging port door will close;
4. The charging port door can be closed when the charging port door on the 3D model of the vehicle on the central screen is operated.

Note: After the charging port door is opened, if the charging gun is not connected within 2 minutes, the charging port door will automatically close.

Note: The charging port door will return to the open state when it encounters an obstacle during closing.

Charging port electronic lock

The slow charging port has electronic lock function. In order to prevent children from contacting the charging gun or accidentally pulling it out during charging, after plugging the charging gun in the slow charging port, the electronic lock in the slow charging port will be locked automatically when certain conditions are met. In this case, do not remove the charging gun to avoid damage. The vehicle must be unlocked before pulling out the charging gun.

Note: After the vehicle is unlocked for tens of seconds, if the charging gun is still plugged into the slow charging port, the electronic lock will automatically lock again.

Charging port electronic lock opening in emergency

In any case, if the automatic unlock of charging port electronic lock fails, you can open charging port electronic lock by pulling the open cable. Open the access port on the left trunk trim panel to expose the open cable of charging port door (pull ring - black).

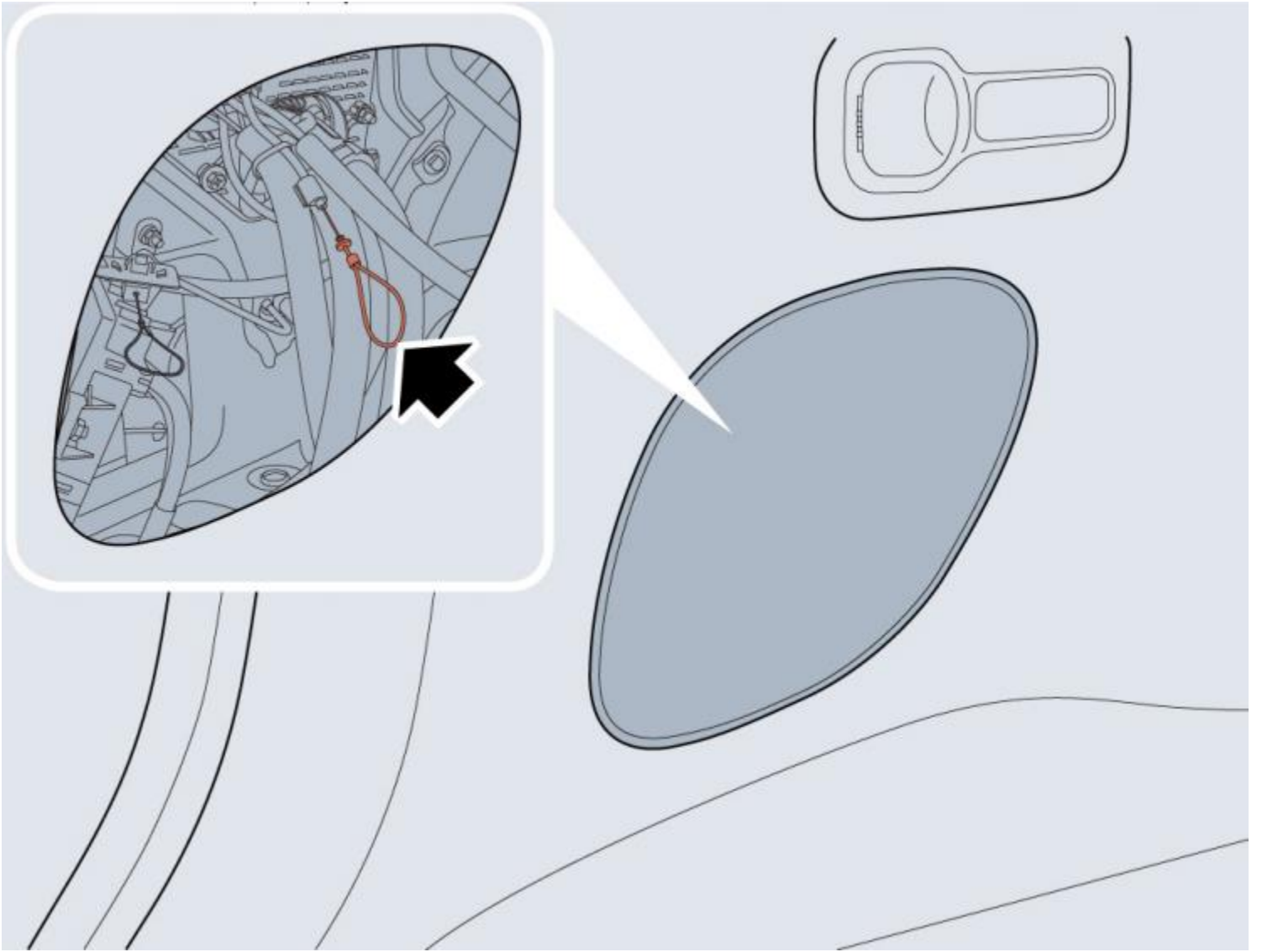

Charging Operations

Fast charging

Before using the fast charging device, please read the Operating Instructions of the device carefully. Different fast charging devices have different operating methods.

Note: Power off the vehicle, wait for 10 seconds and then open fast charging port cap (if equipped).

Slow charging

Slow charging is a charging method to make the high-voltage battery pack reach the optimal equilibrium state. AC charging pile can be used to charge the vehicle slowly.

General charging operations

1. During the charging, power off the vehicle and close all doors.
2. Get off the vehicle and pull out the charging gun, the door can be opened through the central screen or the charging port door switch.
3. Connect the charging gun to the charging port, and lock the vehicle (if the charging port status indicator is green, it is in the charging state).
4. After charging, unlock the vehicle before pulling out the charging gun, and the charging port door will automatically close.

Stop charging operations

1. When the vehicle is unlocked, you can pull out the charging gun to stop charging.
2. You can press the stop button of the charging pile or operate the central screen in the vehicle to end the charging, and then pull out the charging gun.

Scheduled charging

The user can schedule the charging time by the following operations:

1. Enter “My Car” on the central screen, click “Charging Settings” and enter the Charging page;
2. Click “Scheduled Charging”, and enter Scheduled Charging settings page;
3. Swipe to select time, and click “OK” to complete scheduled charging.

Note: The scheduled charging only applies to AC charging.

Charge now

When the vehicle is under scheduled charging, you may click “Charge Now” button at the bottom of the centre display to enter the charging state.

Target charging capacity settings

The user can set the target charging capacity before or during the charging.

1. Enter “My Car” on the central screen, click “Charging Settings” and enter the Charging page;
2. Drag the driving range display grid to set the charging capacity.

IMPORTANT

- To ensure electricity safety, the user should select AC charging pile complying with the requirements of related national standards (such as GB/T 20234, etc.) for charging.

Charging Display

Wired Charging



1. Driving range
2. Remaining charging time

At the beginning of the charging process, the above information will be displayed on the driver screen.

During charging, to view the charging state, you can activate the driver screen to check the current charging state.

Note: The information displayed on the driver screen may vary with different types of vehicles.

Charging Time

Charging time of high-voltage battery pack is related to many factors, such as current electric quantity, charging mode, ambient temperature and charging device power.

Fast charging time

At room temperature, the time taken to charge to 80% of instrument capacity from alarm status (high-voltage battery pack low battery warning lamp alarms) is shown in the table below.

Fast charging method	DC charging pile - 800V	DC charging pile - 400V
From alarm status to 80%	20 minutes	40 minutes

- At low and extreme high temperatures, the charging time will be extended.
- If the charging device has an insufficient output capability, the charging time will be extended.

Note: Considering the safety and service life of high-voltage battery pack, the battery pack may not be fully charged when the fast charging pile is used, therefore, the battery level displayed on the instrument will be less than 100%. Please select a reasonable charging mode based on your vehicle using plan!

Slow charging time

At room temperature, the time taken to charge to 100% of instrument capacity from alarm status (high-voltage battery pack low battery warning lamp alarms) is shown in the table below.

Slow charging method	AC wired charging pile - 7kW					
	800V		400V		400V	
	100kWh		90kWh		77kWh	
From alarm status to fully charged (100%)	Approximately hours	16.5	Approximately hours	14.5	Approximately hours	11.5
From alarm status to fully charged (100%) and equalised	Approximately hours	17.5	Approximately hours	15.5	Approximately hours	12.5
Complete equalisation charge before the first use of a long-time parked vehicle	Approximately hours	19.5	Approximately hours	17.5	Approximately hours	14.5

- At low temperatures, the charging time will be extended.
- If an equalisation charge has not been conducted for a long time, the required charge time will be extended.
- An equalisation charge shall be carried out before the first use of a long-time parked vehicle, and the charging time shall be extended appropriately on the basis of the corresponding charging time in the equalisation charge above to equalize the charge.

Discharge

The vehicle has discharge function, this can convert the high voltage DC power in the high-voltage battery pack into domestic AC power. This discharge function can be realized by using a discharge gun.

Discharge operations

1. Open the charging port door.
2. Insert the discharge gun into the charging port (slow charging port also serves as the discharge port).
3. Enter "My Car" on the central screen, and click "Charging Settings".
4. Click "Discharge", and enter Discharge Settings page.
5. Set the discharge cut-off capacity, and click "Start to Discharge" to enable discharge operations.
6. Click "Stop Discharging" button in the discharge interface to stop the discharge, or stop the discharge after the power is discharged to the set cut-off value.
7. Pull out the discharge gun, and close the charging port door.

Note: During the discharge, the charging port electronic lock will lock the discharge gun. Do not attempt to remove the discharge gun using force, this will cause damage.

Note: During the discharge, the user still can set the "discharge cut-off capacity".

Note: During the discharge, the vehicle cannot be put in READY.

Note: The discharge operations will reduce the driving range.

Note: The maximum discharge power of the vehicle is 6.6kW. Please do not use an electrical appliance with its power exceeding this limit.

Seat

Safe Sitting Position

Warning: To avoid personal injuries due to the loss of vehicle control, do not adjust the seats while the car is moving.

An ideal position of the seat should make sure your driving position is comfortable, which allows you to hold the steering wheel with your arms and legs slightly bent and control all the devices.

Do not incline the front seat backrest too much to the rear. Optimum benefit is obtained from the seat belt with the backrest angle set to approximately 25° from the upright (vertical).

To mitigate the danger possibly caused by airbag triggering, the driver and front passenger seats should be positioned as rearward as practical. Take care when adjusting the height of the front seat: the feet of the rear passenger could be trapped when the seat is lowered.

Seat Headrest

Warning: Do not hang anything on any head restraint or head restraint rod.

The head restraint is designed to prevent rearward movement of the head in the event of a collision or emergency braking, thereby reducing the risk of head and neck injuries.

Front Seat Head Restraint

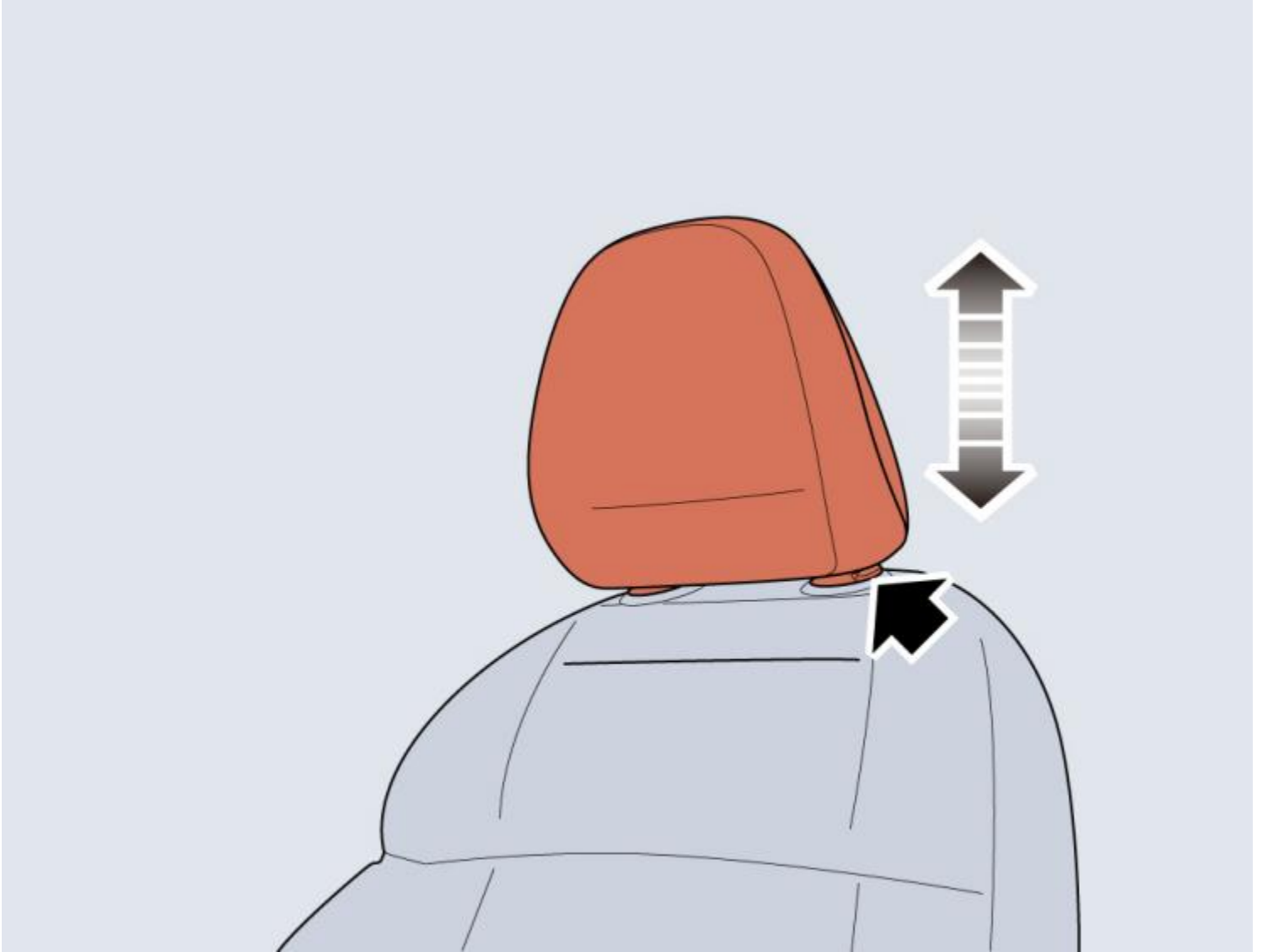

Front head restraint is manually adjustable head restraint. For the adjustment method of manually adjustable head restraint, refer to “Seat Adjustment and Relevant Functions” - “Front Seat Adjustment”.

Rear Seat Head Restraint

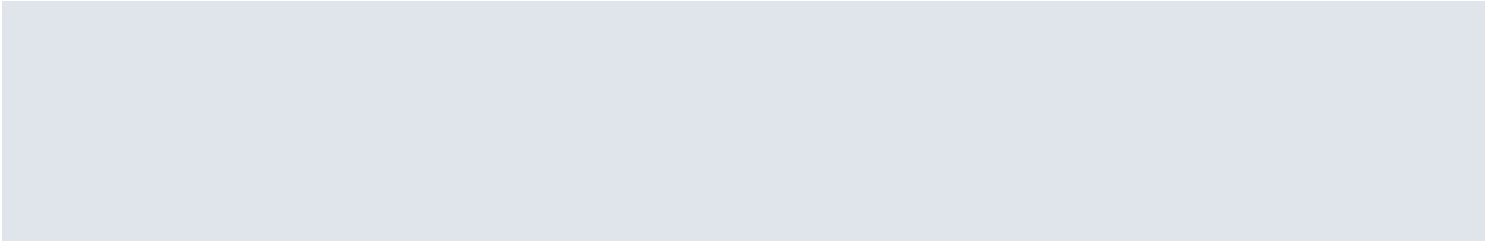

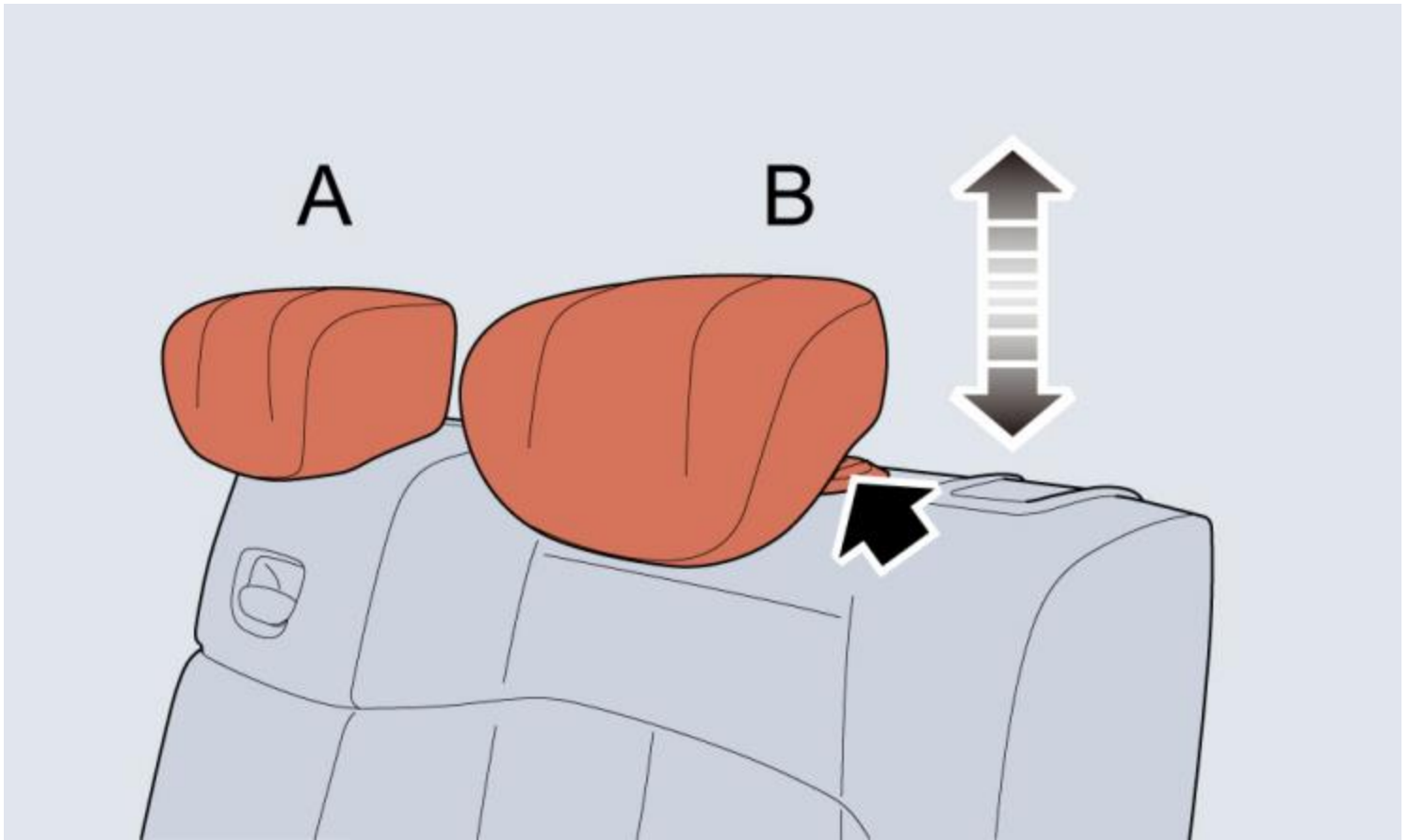

The rear seats of the whole vehicle families are provided with three head restraints.

Rear seat side head restraint is manually adjustable head restraint.

The rear middle head restraint (A) is fixed and cannot be adjusted or removed.

The rear side head restraint (B) is manually adjusted up and down.

When adjusting a head restraint from low to high position, pull the head restraint directly upward, and gently press it downward after it reaches the desired height to make sure that it is locked in position. To remove the headrest, press and hold the guide sleeve button (as indicated by the arrow) on the side of the headrest, and then pull the headrest upward to remove it. When adjusting a headrest from high to low position, press the guide sleeve button (as indicated by the arrow) on the side of the headrest, press the headrest downward; release the button after it reaches the desired height, and gently press the headrest downward to make sure that it is locked in position.

Operation Interface of Seat Functions

Driver Seat Adjustment Interface:

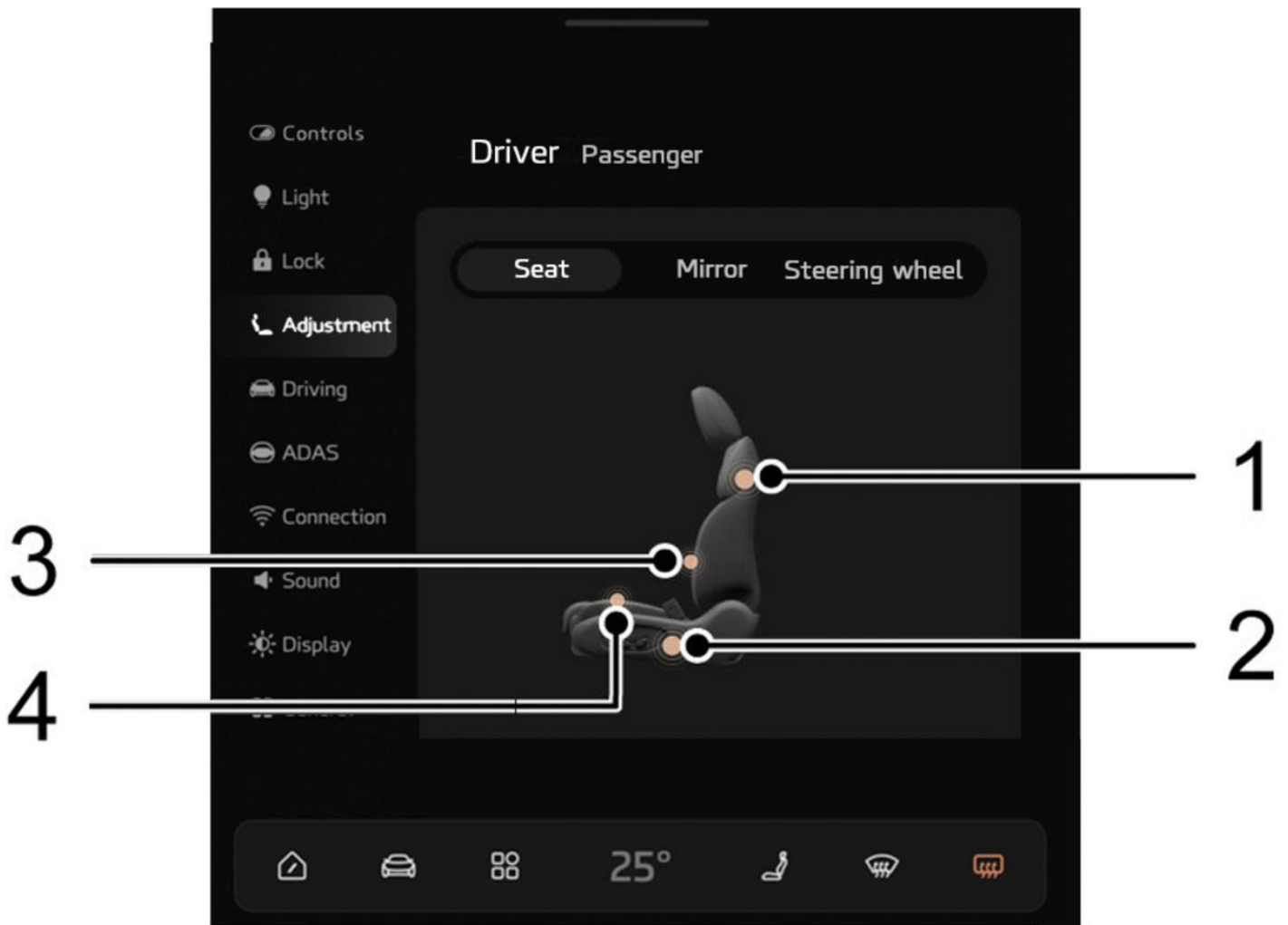

1. Seat Backrest Adjustment Slider;
2. Seat Forward/Backward/Up/Down Adjustment Slider;
3. Seat Lumbar Support Adjustment Slider;
4. Seat Cushion Adjustment Slider;

Front Passenger Seat Adjustment Interface:

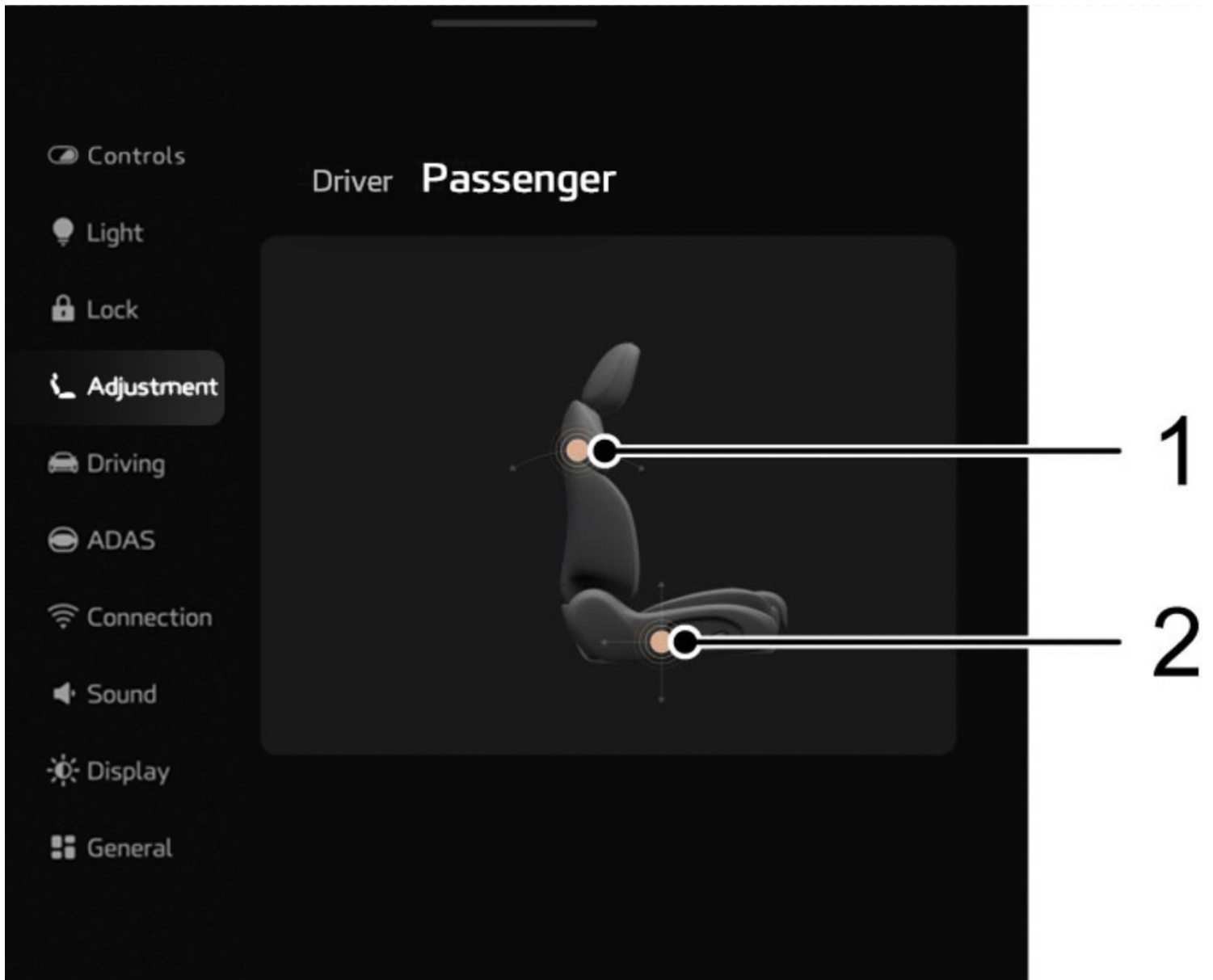

1. Seat Backrest Adjustment Slider;
2. Seat Forward/Backward/Up/Down Adjustment Slider;

Seat Adjustment and Relevant Functions

The user can adjust the front seat by operating the buttons on the exterior trim panel of the seat. The front seat can be also adjusted by operating the relevant interfaces on the central screen.

The heating and ventilation other functions of the seat can only be enabled after the vehicle is powered on or started, and the heating and ventilation functions of the seat cannot be enabled at the same time.

Front seat adjustment

Warning: When adjusting the front seat, take care not to get your hands or feet caught in moving parts.

Take the driver seat as example:

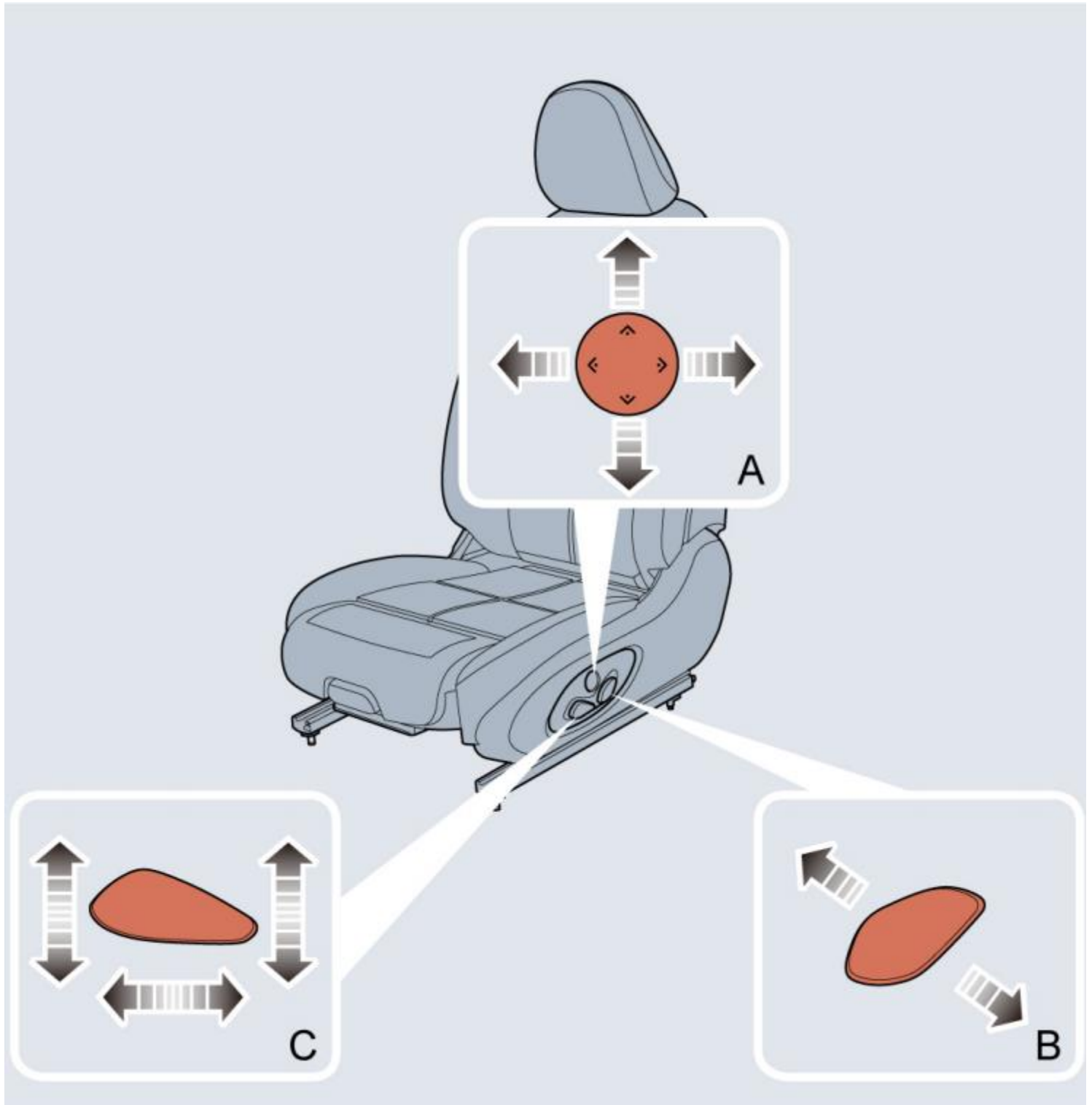

- Lumbar support adjustment

To adjust the lumbar support, you can long press the corresponding direction button (A).

- Backrest angle adjustment

To adjust the seat backrest angle, you can push the button (B).

- Forward/rearward adjustment

To adjust the forward/rearward position, you can push the button forward and rearward (C).

- Seat height adjustment

To adjust the seat height, you can push the rear end of the button up and down (C).

Rear seat adjustment

Warning: When adjusting the rear seat, take care not to get your hands or feet caught in moving parts.

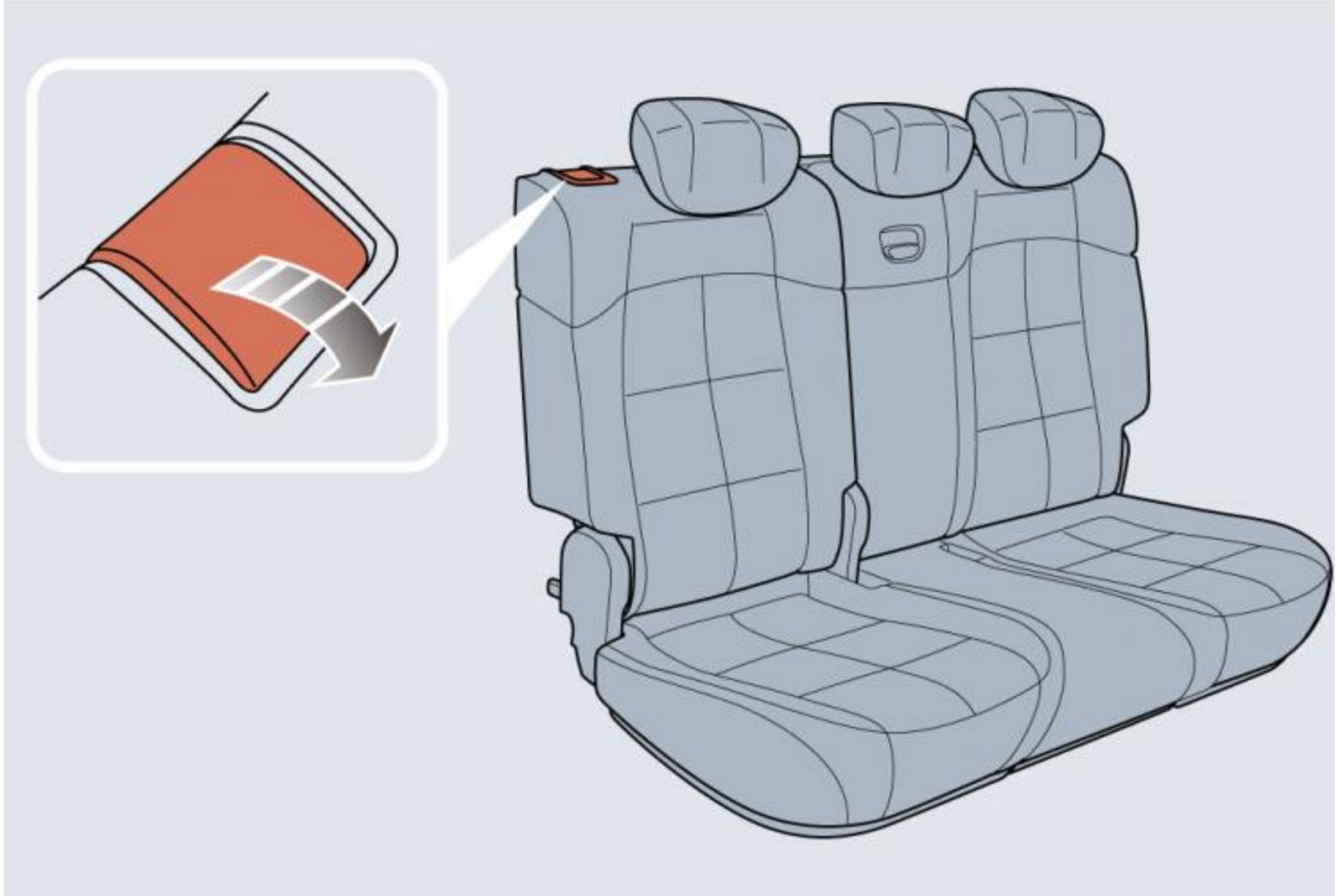

Folding of rear seats:

The rear seat backrests can be fully folded forward to provide larger rear space. Before folding the backrest, please adjust the headrest to the lowest position. Pull up the control handle respectively on both sides to fold the seat backs forward. To unfold the backrest again, pull up the control handle on both sides to unfold the rear seat backs upward to the rearmost position until a "click" sound is heard, which indicates complete unfolding.

Note: When the driver seat backrest is inclined backward excessively, the folding of the rear seat backrest is very likely to damage the back of the front seat or the rear seat headrest.

Note: When returning the rear seat backrest to the desired position, make sure that the rear seat belt is not trapped.

Seat heating

Warning: If bare skin is in contact with the heated seats for excessive periods of time, it may cause low temperature burns.

All front seat backrests and cushions of the whole vehicle families have heating function.

The user can enable, disable or adjust the corresponding seat heating function through the Seat Operation interface on the central screen.

The heating function has a total of three levels of adjustable intensity.

Note: When the high level of seat heating intensity is used for a long time, the system will automatically reduce its level.

IMPORTANT

- Do not cover the heated seats with blankets, cushions or other insulation type objects or materials.

- When the seat is heated to exceed a certain temperature and continues getting hotter, please turn off the switch and contact the Authorised Repairer for inspection and service.
- Overuse of the driver's heated seat may cause drowsiness and could affect safe driving.

Seat ventilation

The front seat of the whole vehicle families have a ventilation function. The user can enable, disable or adjust the ventilation function through the Seat Operation interface on the central screen.

The ventilation function has a total of three levels of adjustable intensity.

Seat Positions and Backrest Angle State

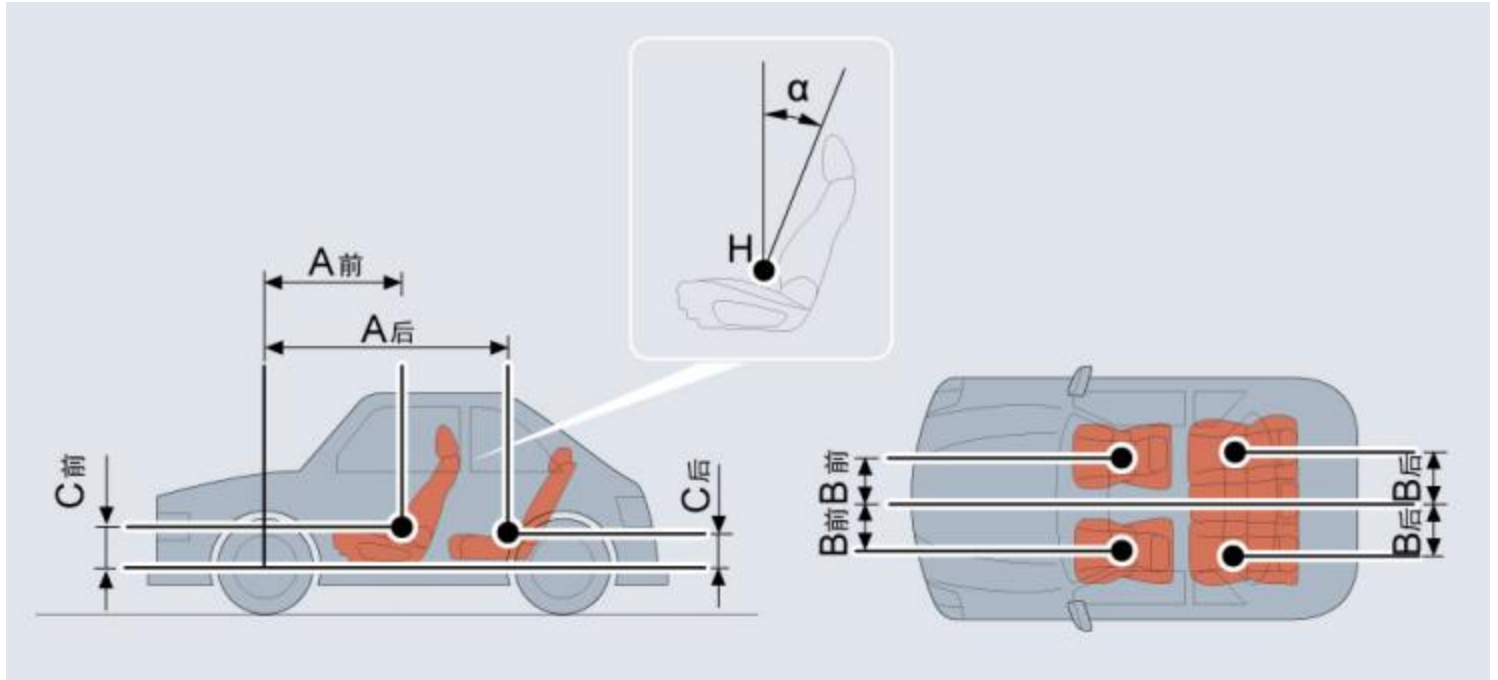

In accordance with the requirements set forth in *Safety Specifications for Motor Vehicles Operating on Roads* (GB7258–2017), the data related to the seat positions and the backrest angle set by the engineering design are listed below.

	Front seat	Front seat	Rear seat	Rear seat	Rear seat
	Left	Right	Left	Middle	Right
A, mm	1460	1460	2385	2315	2385
B, mm	385	385	370	0	370
C, mm	337	337	364	416	364
α , °	25	25	25	25	25

Note:

A=The distance from the H point on the seat to the vertical plane where the centre of the front wheel is located;
 B=The distance from the H point on the seat to the centre symmetrical surface of the left and right sides of the vehicle;
 C=The distance from the H point on the seat to the horizontal plane where the center of the front wheel is located;
 α =Seat backrest angle

Note: The seat positions will be expressed by using H point as the reference point (H point is the connection point between the human torso and the thigh, i.e., hip point). The data in the table are the measuring results obtained in the unladen condition of the vehicle.

Personalized Setting of Seats with Memory Function

The driver seat of the whole vehicle families have a seat position memory function.

Setting and invocation of seat memory position

Warning: Do not invoke the seat memory position during driving, otherwise there is a risk of accident due to the unexpected movement of the seat.

Driver seat

When the vehicle is powered on or started, the user adjusts the seat to his/her most comfortable position, and clicks the "Save" button of the corresponding seat in the Seat Operation interface on the central screen, the current seat position will be saved. To invoke the saved seat position, click the "Restore" button of the corresponding seat.

When the Seat Backward button is pressed, a pop-up window will appear on the central screen. When the user clicks the "Stop Moving" button in the pop-up window, the pop-up window will disappear, and the user can directly get out of the car, however, in which case, the seat position cannot be saved; when clicking the "Adjust Seat" button, the user can adjust the seat forward and backward and save the seat position.

IMPORTANT

When invoking the seat memory position, please note that there is no object hindering the seat moving path, otherwise the seat surface may be damaged or the memory position may fail to be invoked.

Driver seat welcome function

The welcome function of the seat is designed to facilitate the user to enter and exit the vehicle, and allow the seat to automatically move forward and backward.

This function is only available when "More Settings" is clicked in the Seat Operation interface on the central screen to enable the convenient access functions of the driver seat.

1. Exiting the car: When the user parks the vehicle, engages it in P gear, releases the seat belt and opens the door, the seat will automatically slide back to some distance to provide larger front space for the drivers and passengers to get out of the car.
2. Entering the car: Unlock the vehicle, open the door, get in and take a seat. When the door is closed or the brake pedal is pressed, the seat can automatically move forward to its last memorized position.

Note: The welcome function of seat is unavailable when the vehicle detects that the rear seats are occupied.

Seat Belt

Instructions for Use of Seat Belts

Warning: It is important that all seat belts are worn correctly. Always check that all passengers are wearing seat belts. The following situations where seat belts are fastened improperly may cause serious injury or even death in the event of emergency brake or collision:

- Sit in a seat unable to wear seat belt properly.
- Use an alternative to insert into seat belt buckle while not wearing seat belt during driving.
- Unfasten a seat belt whilst driving.

Warning: Airbags can not replace seat belts. Airbags can only provide extra support when triggered, and not all traffic accidents will trigger airbags. Whether airbags are triggered or not, wearing seat belts properly can reduce the risks of serious injury or death in accidents.



This vehicle is equipped with seat belt warning lamp to remind you to fasten your seat belt. Refer to "Warning Lights and Indicators" in "Instrument Pack" section for details.

When the vehicle is moving, seat belts must be fastened properly for all occupants. The seat belt shall be fastened even for short-distance travel. Because:

1. You can never predict if you will be involved in a collision accident and how serious it may be.
2. The experience has clearly demonstrated that whether seat belts are properly fastened matters most to the effective protection for the passengers in many collision accidents!

Protection Provided by Seat Belts

Warning: It is of equal importance for passengers in the rear seats to fasten their seat belts correctly. Otherwise, passengers with seat belts not correctly fastened will be thrown forward in accidents, and it will endanger themselves as well as the driver and other passengers.



When the vehicle is in motion, the moving speed of the passengers is identical to the running speed of the vehicle. In the event of frontal collision accident or emergency brake, the passengers not having the seat belt fastened properly will continue moving forward at the speed before collision due to inertia instead of stopping immediately until they come into contact with a stationary object. These objects may be the steering wheel, instrument panel, windscreen or any object in the way of forward movement.

For the passengers having the seat belt fastened properly, they will slow down together with the vehicle because of the automatic locking function of the seat belt, so as to prevent the out-of-control movement which may cause serious injury to the driver and passengers. Under the protection of seat belt, you will have longer distance and more time to stop moving, and the strongest bone in your body will bear the impact force. That is why it is important to fasten the seat belt correctly.

When minor traffic accident occurs, trying to shore up your body with arms is very dangerous. Even the low speed collision will generate force that arms and hands can not support, therefore, seat belts must be worn correctly during driving.

How to Wear Seat Belts Properly

Warning: Incorrectly worn seat belts could cause injury or death in the event of an accident.

Warning: Seat belts are designed for one person. DO NOT share a seat belt.

Warning: DO NOT wrap a seat belt around when holding a baby or child in your arms.

Warning: Remove any heavy coats or clothing when wearing a seat belt, failure to do so can affect protection provided by the seat belt.

Warning: Seat belts should not be wrapped around hard or sharp objects such as pens, spectacles or keys to avoid additional injury to the users.

Warning: Do not drive when the seats are excessively reclined. As seat belts cannot function correctly when the seats are reclined excessively. When accident occurs, the passenger's body may cross the shoulder belt, causing damage to the neck or other parts. Lap belt may slide to your abdomen and apply force on it, which will cause serious injury.

The seat belts fitted to your vehicle are designed for use by normal sized adults. This part of the literature refers to adult use. For advice on seat belt use with children, please see "How Children Use Seat Belts".

In order to maintain effective protection, the passengers must sit in the correct orientation, placing feet on the floor in front of them, with an upright body against the backrest (no excessive recline) and the seat belt correctly fastened.

IMPORTANT

- Always ensure the seat belt will not be trapped in the door aperture when closing the door, otherwise damage will occur.
- Pulling the lap-shoulder seat belt out too quickly may cause it to be locked. In this case, allow the seat belt to retract slightly, unlock it and then pull it across your body slowly.
- If it is difficult to pull the seat belt out, it may be due to twisted webbing in side trim panel. If this is the case, pull the metal tab, fully extract the seat belt, remove the twist, and allow the seat belt to retract slowly.
- Even if the seat belt is not completely smoothed, it is still required to be worn during driving, but the twisted part of the seat belt shall not contact the passenger. When this happens, please go to an Authorised Repairer for repair.

Correct Routing of the Seat Belts

Warning: Ensure the seat belt is correctly positioned on the body, never cross the neck or abdomen, and never pass the seat belt behind the back or under the arms.

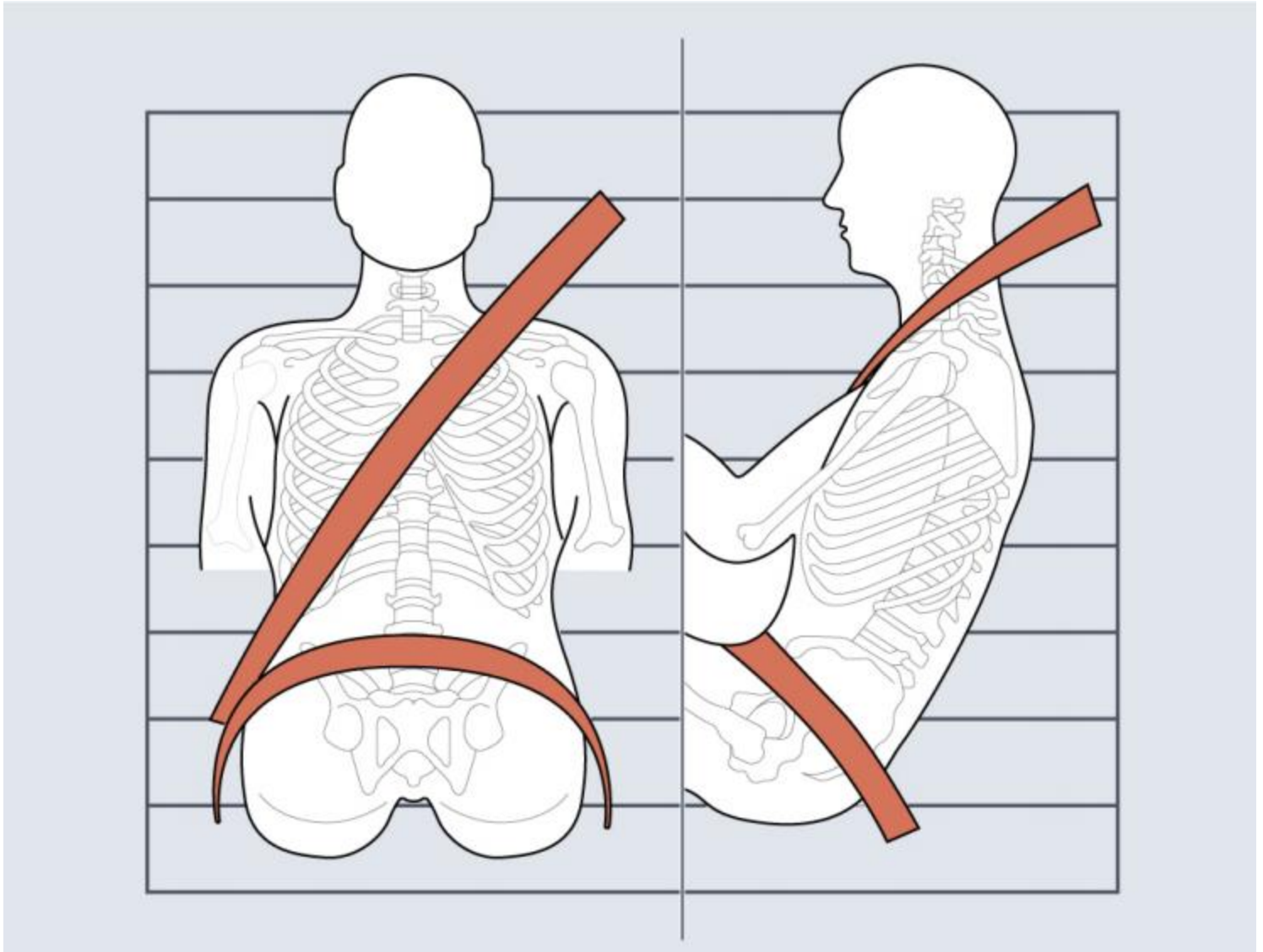

When wearing seat belts, the lap belt section should be positioned as low as possible across your hips and just in contact with your thighs (never cross the abdomen), so that in a collision accident, the lap belt can apply force to the firm hips, reduce the possibility of body moving under the lap belt, and maximize the protection for passengers against injury.

The diagonal section of the belt should cross the middle of the shoulder and the chest. In the event of emergency braking or collision, the diagonal section of the belt will be locked. Never cross your neck, arms, or cross under your arms or behind your back.

To ensure that the seat belts always provide maximum protection, ensure the belt is flat, not loose and contacts the body properly. Adjust seat belt to ensure it is not loose.

Seat belt use during pregnancy

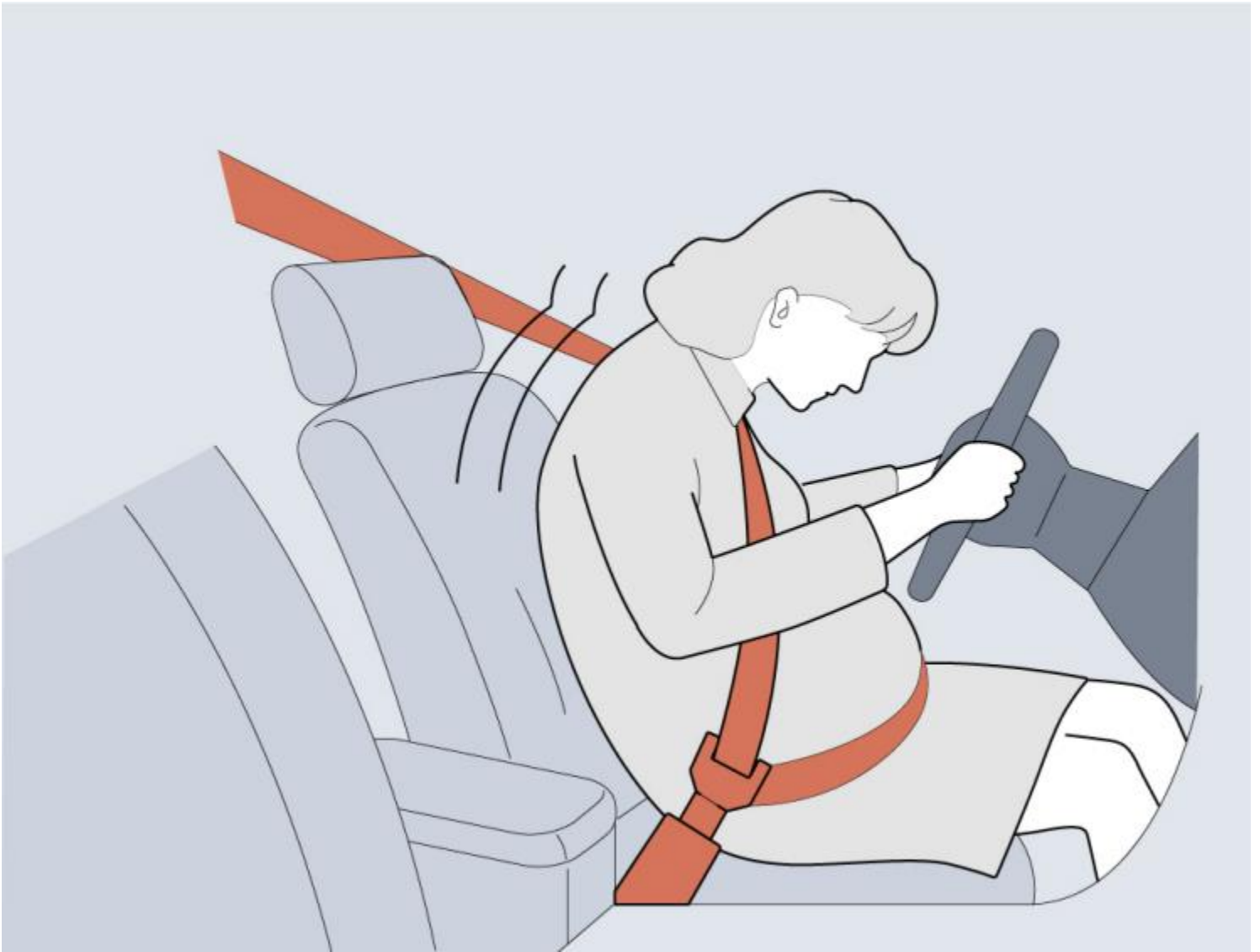

Wearing correctly positioned seat belts will provide protection for both mother and unborn child in the event of a collision or emergency braking. Like all passengers, the pregnant woman may suffer from more serious injury in collision accidents or sudden stop if she does not wear the seat belt correctly.

During the whole pregnancy, the pregnant woman shall wear the lap-shoulder seat belt correctly. The diagonal section of the seat belt should pass across the chest as normal. The lap section of the belt should be as low as possible across below the belly, and snug on the hip bones. The seat belt must be flat so as not to cause pressure on the lower body of the pregnant woman.

Please consult your physician for further details.

Seat Belt Use for Disabilities

People with disabilities should also wear seat belts correctly.

Please consult your physician for further details.

Lap-shoulder Belts

All seat belts fitted on this vehicle are lap-shoulder belts. Please follow the instructions below to fasten lap-shoulder seat belts correctly.

1. Hold the metal tab, pull the seat belt out steadily over the shoulder and across your chest. Ensure there is no twist on the belt.

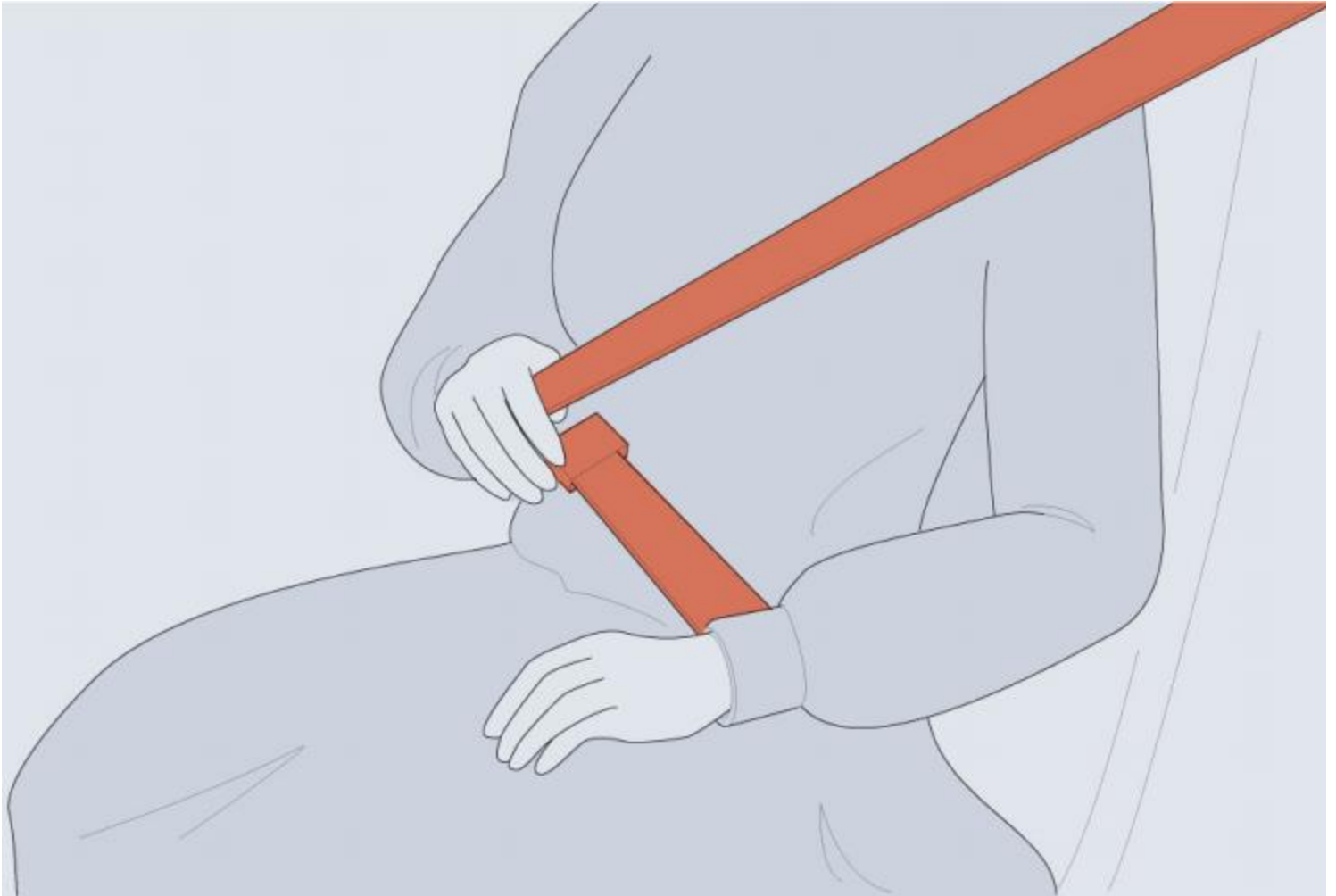

2. Insert the metal tab into the buckle until you hear a "click", this indicates the seat belt is securely locked.

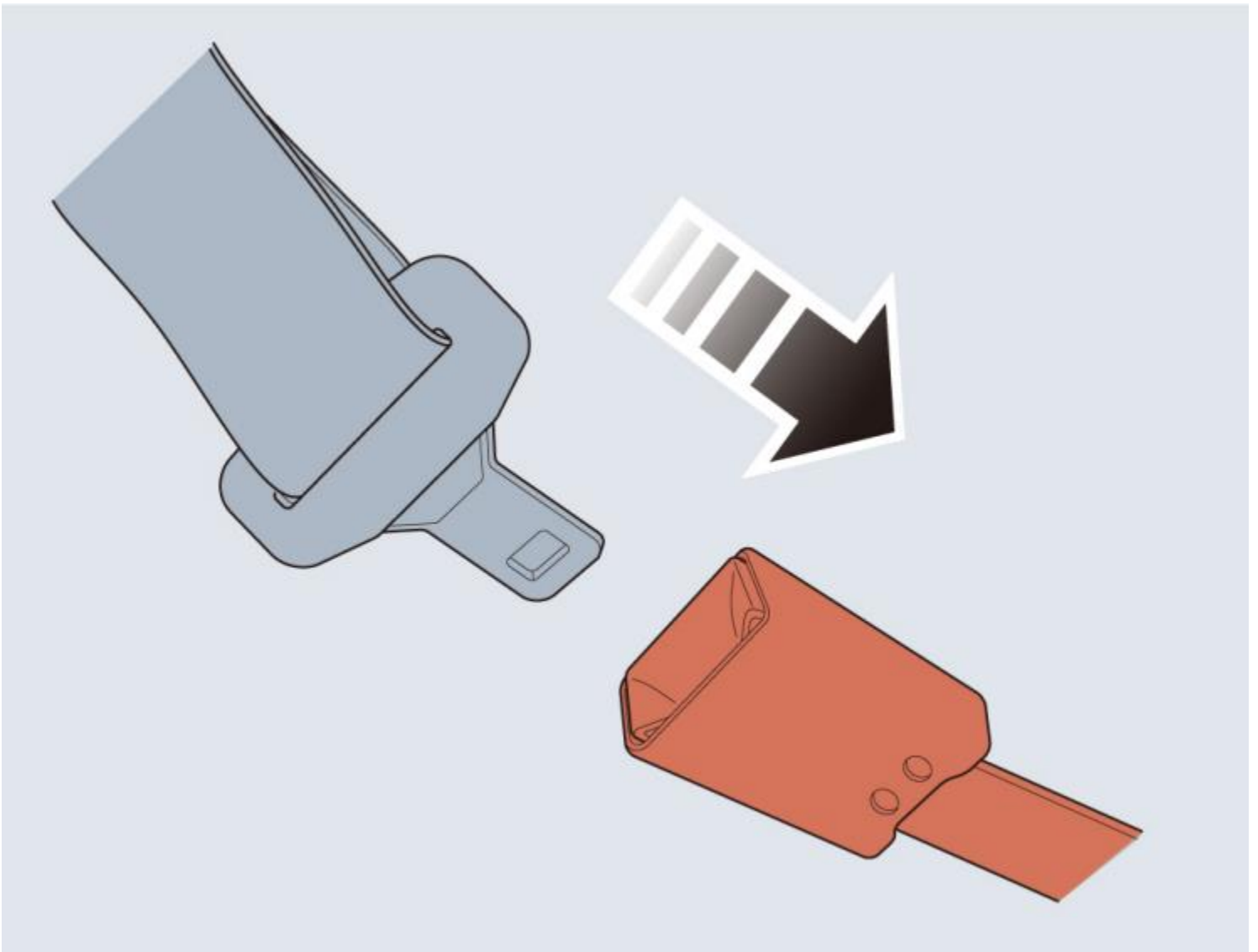

3. Pull the shoulder belt upward and tighten up the lap belt.

4. To release the seat belt, press the red button on the buckle, and the metal tab of the seat belt will automatically pop out. When the seat belt is released, the metal tab will automatically retract to its original position.

Upper Anchor Point Height Adjustment

Warning: During driving, DO Not adjust the height of seat belt.

Warning: Make sure the seat belt upper anchor point has been adjusted to proper height and locked in place, or injury even death may be caused in the event of collision accidents.

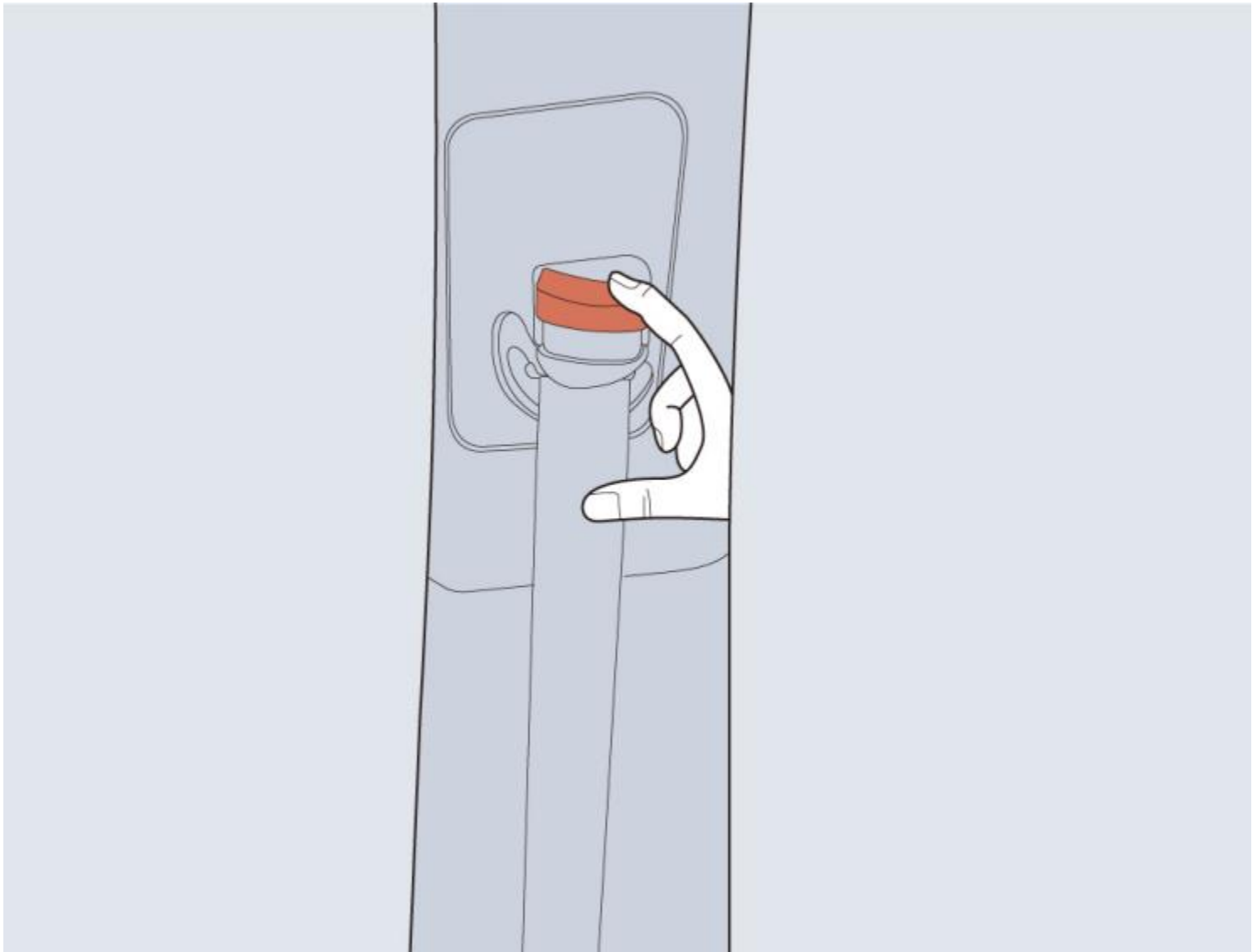

The trim panel beside the front seat of the vehicle is equipped with a seat belt upper anchor point adjuster to adjust the height of the shoulder belt, so that the shoulder belt can pass through the middle of the human shoulder. The shoulder belt shall be positioned away from the neck and head, however, it cannot be positioned below the shoulder.

Please follow the instructions below to adjust the seat belt upper anchor point correctly:

1. Hold the seat belt.
2. Press release button and move the height adjuster to desired position. Move the adjuster by pushing the slider.
3. After moving the adjuster to desired position, release the button and try to move the adjuster downward to determine whether it is locked in place.

Note: Incorrect positioning will reduce the efficiency of the seat belt in the event of a collision or emergency braking.

How Children Use Seat Belts

Warning: Proper protection measures must be taken for children during driving.

For safety reasons, children shall ride in child restraint device fixed to the rear seat.

Infants

Warning: Only recommended child restraints suitable for the age, height and weight of the child should be used.

Warning: Never carry a child or infant with your arms during driving. When collision accidents occur, the weight of child will produce so great force that you can not hold the child. The child will be thrown forward and suffer serious injury or even death.

Seat belts for adults are not suitable for young children, because seat belts can not lock their hips tightly. If collision accidents occur, they will suffer from serious injury or even death. Therefore, they shall be given special protection.

Infants shall use child restraint device. You shall choose the proper restraint device suitable for your vehicle and child, and install and use it in accordance with the instruction of manufacturer. Please refer to "Child Restraints" in this section for more details.

Elder Children

Warning: Sharing the same belt among children is never allowed. Children will huddle and be seriously injured in case of accidents.



When the children are heavy and beyond the age of using children restraint device, they shall use seat belts equipped on the vehicle.

Please make the children sit up and use lap-shoulder seat belts, so that the shoulder belt can provide more effective protection. According to accident statistics, children are safer if they sit on rear seat and wear seat belts correctly.

Check seat belts for proper position in time. Adjust the height of seat belts to keep the shoulder belt away from children's face and neck. Lap belt shall cross the hips as low as possible, just touch the thigh and tightened properly. In this way, seat belts can pass the applied force to the strongest part of children body in accidents.

If the shoulder belt is too close to children's face or neck, please buy and use children boost cushion that meets relevant law or standard.

Children boost cushion can boost children to the height where the shoulder belt cross just the middle of the shoulder and lower the lap belt to hips.

Seat Belt Pre-tensioners

Warning: The seat belt pre-tensioners will only be activated once and then **MUST BE REPLACED**. Failure to replace the pre-tensioners will reduce the efficiency of the seat restraint system.

Warning: If the pre-tensioners have been activated, the seat belts will still function as restraints, and must be worn in the event that the vehicle remains in a drivable condition. The seat belt pre-tensioners should be replaced at the earliest opportunity by an Authorised Repairer.

The vehicle is fitted with seat belt pre-tensioners besides some seat belt retractors. Although the seat belt pre-tensioner remains invisible, they are part of the seat belt assembly. Seat belt pre-tensioner works together with airbags to protect drivers and passengers. When medium or severe frontal collision occurs and meets the condition to activate the pre-tensioner, the pre-tensioner will help to secure the seat belt to reduce passengers moving forward.

The airbag warning light on the instrument pack will alert the driver to any malfunction of the seat belt pretensioners (see “Warning Lights and Indicators” in “Instrument Pack” section).

The seat belt pre-tensioners can only be activated once, after activation they must be replaced. This may also involve replacement of other SRS components. Please refer to “Service and Replacement of Airbags” in “Airbags” of this section.

IMPORTANT

- Seat belt pre-tensioners will not be activated by minor impacts.
- The seat belt pre-tensioners are safety parts, and their removal or replacement must be carried out by professionals according to the technical specification and processes. For better guarantee of your safety, we recommend you consult an Authorised Repairer.
- After 10 years from the use (or replacement of seat belt pre-tensioner) of the vehicle, it is recommended to replace the seat belt pre-tensioner assembly to guarantee your safety. If you have any doubt about the device within this period, we recommend you consult an Authorised Repairer.

Seat Belt Checks, Maintenance and Replacement

Seat Belt Checks

Warning: Split, worn or frayed seat belts may not function correctly in the event of a collision. They may be cracked by the impact force. If the seat belt is split or worn, have it replaced immediately.

Warning: Ensure the red release button of seat belt buckle keeps upward or outward, so that seat belts can be unfastened rapidly in emergency.

Please follow the instructions below to check the seat belt warning light, seat belt, metal tab, buckle, retractor and fixing device regularly for normal operation:

1. Insert the seat belt metal tab into the corresponding buckle and pull seat belt webbing close to the buckle quickly to check that the belt clasp locks.
2. Hold the metal tab and pull the seat belt forward quickly to check that the seat belt reel locks automatically, preventing the webbing from extending.
3. Fully extract the seat belt and visibly examine for twists, fraying, splits or worn areas.
4. Retract the seat belt and allow to return slowly to ensure continual and complete smooth operation.
5. Visibly examine the seat belt for missing or broken components or components that may affect the normal operation.
6. Ensure the seat belt warning light is fully functional.
7. If the seat belt fails any of the above tests or inspections, contact an Authorised Repairer immediately for repairs.

Seat belt maintenance

Warning: DO NOT modify or remove seat belts without authorization. The repair of a seat belt component must be carried out by professionals according to the technical specification and processes. In the event of accidents, improper maintenance may cause seat belt pre-tensioners not to be activated normally to increase accident injury risk. For better guarantee of your safety, we recommend you consult an Authorised Repairer.

Warning: Ensure no sharp objects be lodged in the seat belt mechanisms. Do not allow liquids or foreign objects to enter the seat belt buckle, which could affect the buckle engagement.

Seat belts should only be cleaned with neutral soap and warm water. Do not use any solvent to clean the seat belt. Do not attempt to bleach or dye the seat belt, which may weaken the seat belt. After cleaning, wipe with a cloth and allow to dry.

Do not allow the seat belt to fully retract before it is completely dry. Keep seat belts clean and dry.

If there are contaminants accumulated in the retractor, the retraction of seat belt will be slow. Please use a clean and dry cloth to remove any contaminants.

Seat belt replacement

Warning: Collision accidents may damage the seat belt system. The seat belt system may not be able to protect users after damage, which may result in serious injury or even death. After an accident, seat belts should be checked and replaced as needed immediately.

Seat belts may not require change after minor collisions. However, some other parts of the seat belt system, like metal tab, buckle, retractor, etc, may be deformed or damaged in the collision. Please go to an Authorised Repairer for repair or replacement of seat belt assembly.

Airbag

Airbag Overview

Warning: The airbag provides additional protection in a severe impact only. It is intended to assist, rather than to replace the protective role of the seat belt in an accident. Even the vehicle is equipped with airbags, seat belts still must be worn properly, otherwise you may suffer from severe injury or even death in a collision.

Warning: The airbags together with lap-shoulder seat belts provide optimum protection for adults, but it is not the case for infants. The seat belt and airbag systems in the vehicle are not designed for protecting infants. The protection required by infants should be provided by child restraints.

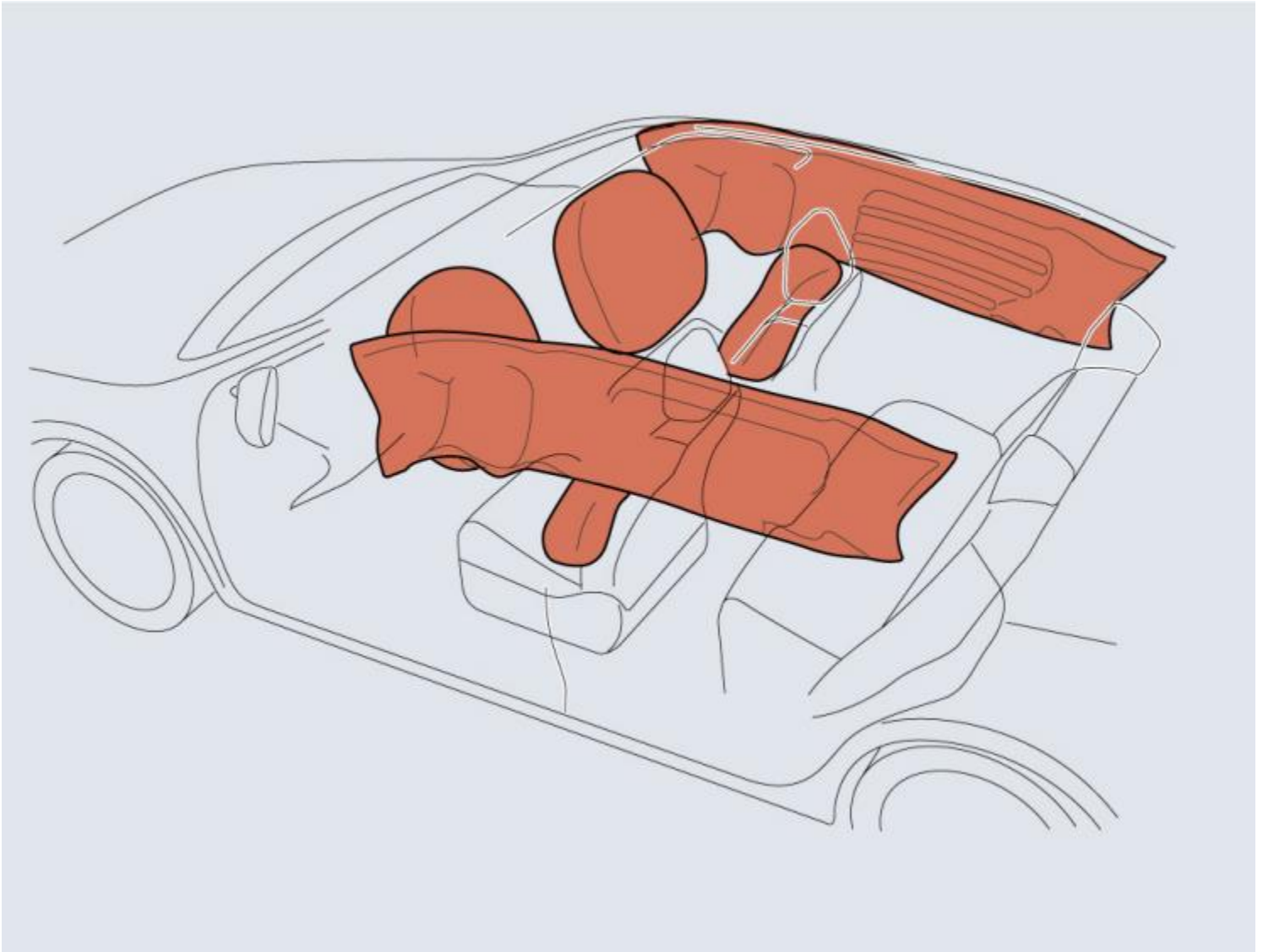

The airbag system of the whole vehicle families consists of:

- Two frontal airbags (fitted in the centre part of the steering wheel and the instrument panel above the glove box respectively)
- Two side airbags (fitted in the outer seatback cushion of the two front seats)
- Two side curtain airbags (fitted in the roof interior trim on both sides)

In the corresponding place where airbags are fitted, there is a warning sign stating 'AIRBAG'.

Airbag Deployment

Warning: Incorrect sitting posture, sitting on or leaning against the positions close to airbag may lead to severe or even fatal personal injury when the airbag is deployed.

Warning: To minimise the risk of accidental injury from inflating airbags, seat belts should be worn correctly at all times. Driver and front passenger must take correct sitting posture and adjust their seat to keep sufficient distance from front airbags, so as to avoid serious injury or death caused by deployed airbags. If side airbags and side curtain airbags are fitted, both driver and front seat passenger should be seated to maintain sufficient distance from the upper part of the body to the sides of the vehicle, this will ensure maximum protection when the side airbags/side curtain airbags are deployed.

Warning: When airbags are deployed, children without proper protection may suffer from serious injury or even death. Do not carry children in the arms or on the knees during traveling. Never let your children ride in unprotected case. DO NOT lean any part of the body out of the window.

Warning: Airbag deployment may cause abrasions on the body surface, body bruises, or burns due to the explosion.

Warning: The inflation passage of the airbag must be free of any obstructions. Do not place any objects between passengers and airbags. It is prohibited to fix or place any objects on the steering wheel cover, or near the front airbag cover of the instrument panel. DO NOT affix or place any accessories or ornaments adjacent to the airbag system. If there is an obstacle between the passenger and airbag, the airbag may not inflate properly, or the airbag will squeeze the obstacle into the passenger's body causing serious injury or even death.

Warning: When airbags are deployed, airbag related components in the steering wheel and instrument panel and at both sides of the roof rails above front and rear doors will become very hot. Do not touch airbag related components immediately after the airbags are deployed to avoid injuries.

Warning: DO NOT knock or strike the position where airbags or related parts are located, so as to avoid accidental airbag deployment which may cause serious injury or even death.

In the event of a collision, the airbag control module monitors the rate of deceleration or acceleration induced by the collision, to determine whether the airbags should be deployed. Airbag deployment is virtually instantaneous and occurs with considerable force, accompanied by a loud noise.

In the event of a severe frontal collision, a completely deployed airbag, along with a correctly worn seat belt, can limit the movement of the driver and front passenger, reducing the risk of head and chest injuries. For vehicles fitted with side airbags and side curtain airbags, when the vehicle encounters serious side collision, the completely deployed airbag will form a cushion of air between the occupant and the vehicle side to reduce the risk of body side injuries.

When you sit upright in the seat and against the backrest, seat belts and airbags can provide the most effective protection. When encountering serious collision, airbags will deploy drastically. At this moment, if you or other passengers do not use seat belts properly, and lean forward, recline or sit in other incorrect postures, you or other passengers are likely to suffer from serious injury or fatal injury.

IMPORTANT

- Airbags can not protect lower body parts of passengers.
- Airbags are not designed for rear collision, minor frontal impacts, or vehicle overturns; nor will it operate as a result of heavy braking.
- Deployment and retraction of the front and side airbags takes place very quickly and will not protect against the effect of the secondary impact that may occur.
- When an airbag inflates, some fine powders are released. This is not an indication of a malfunction, however, the powder may cause irritation to the skin and should be thoroughly flushed from the eyes and any cuts or abrasions of the skin. If skin (eyes, nose, throat, etc.) gets irritated, please go to a doctor immediately.
- After inflation, the airbags deflate immediately. This ensures that the driver's forward vision is not obscured.

Front airbags

Warning: NEVER fit child restraint in the front passenger seat. The deployment of front airbag may cause serious injury or even death to children.

Warning: Driver and front passenger shall not place feet, knees or any other part of the body against the front airbag cover, to avoid severe or even fatal personal injury when the airbag is deployed.

Warning: The airbag may deploy when the chassis of the vehicle is subjected to severe turbulence or accidental impact. Please take extra care when driving on bumpy or potholed roads, so as to avoid injury due to accidental airbag deployment.

Front airbags are designed to deploy during serious frontal impacts or similar impacts. Conditions described below or similar ones may cause airbag deployment:

- A frontal collision with unmovable or non-deformable solid wall at a high speed.

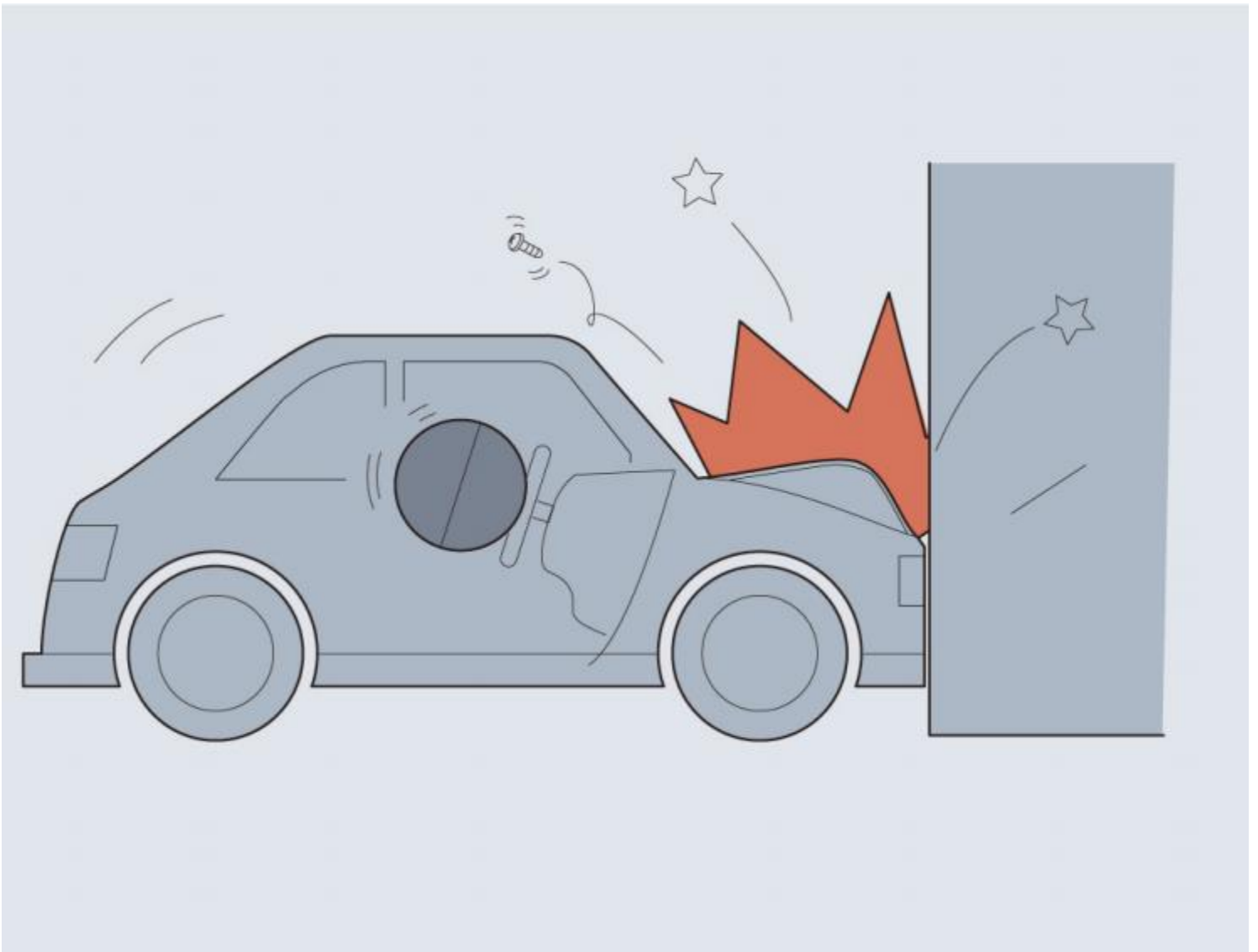

- Vehicle chassis are seriously damaged. Serious chassis damage may be caused by the following conditions: a collision with kerbstones, road edges or hard surface; falling into deep ravines or holes; or hitting the ground violently after jumping up.

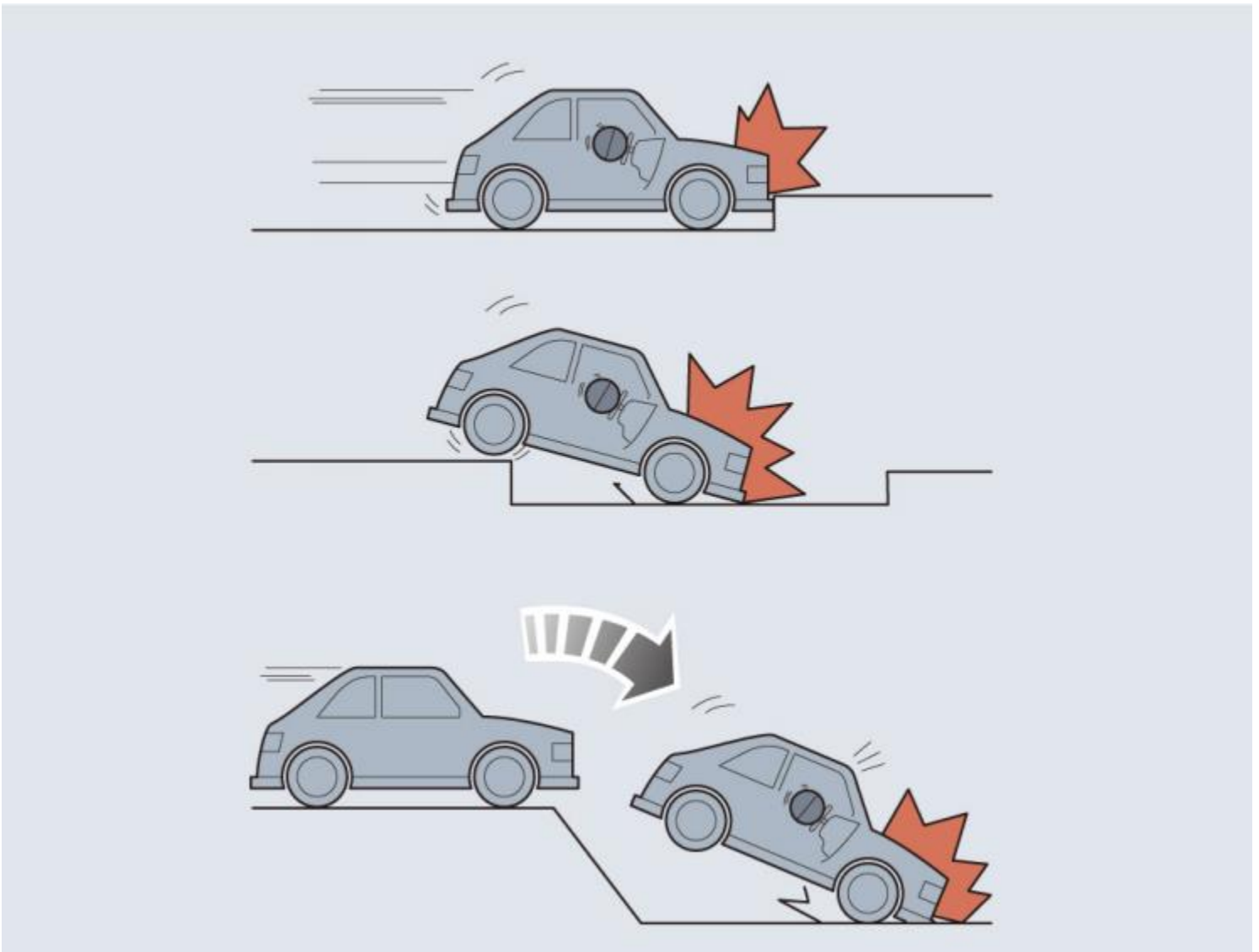

Side Airbags, Centre Airbag and Side Curtain Airbags

Warning: The structure and material of the seat is important to ensure correct operation of airbags. Therefore, please do not fit seat covers which may affect the deployment of side airbag and middle airbag.

In the event of a serious side impact, the front side airbag on the impacted side will deploy quickly from the outer seat backrest cover, the side curtain airbag will deploy quickly from the roof interior trim, and the centre airbag will deploy quickly from the inner backrest cover of the driver seat. The side airbag and side curtain airbag on the other side will not deploy. Conditions described below or similar ones may cause side airbag, centre airbag and side curtain airbag deployment.

- One side of the vehicle collides with high-speed ordinary passenger car.

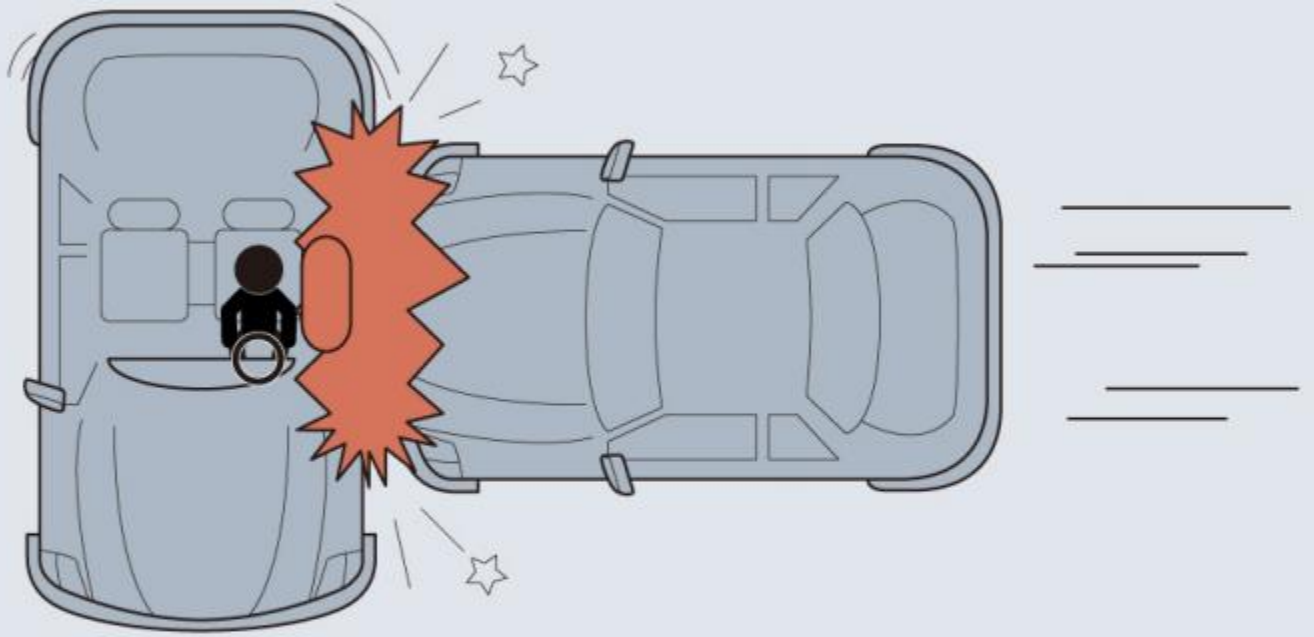

Conditions in Which Airbags Will Not Deploy

The deployment of airbags does not depend on the vehicle speed, but on the object that the vehicle hits, angle of impact and the rate at which the car changes speed as a result of a collision. When the impact force of collision is absorbed or dispersed to vehicle body, airbags may not deploy; however, airbags may sometimes deploy according to impact condition. Therefore, the deployment of airbags shall not be judged based on the severity of vehicle damage.

Front airbags

Under conditions described below or similar ones, the front airbags may not deploy:

- The impact point is not central to the vehicle.
- The impact is with a solid utility pole or traffic sign post.

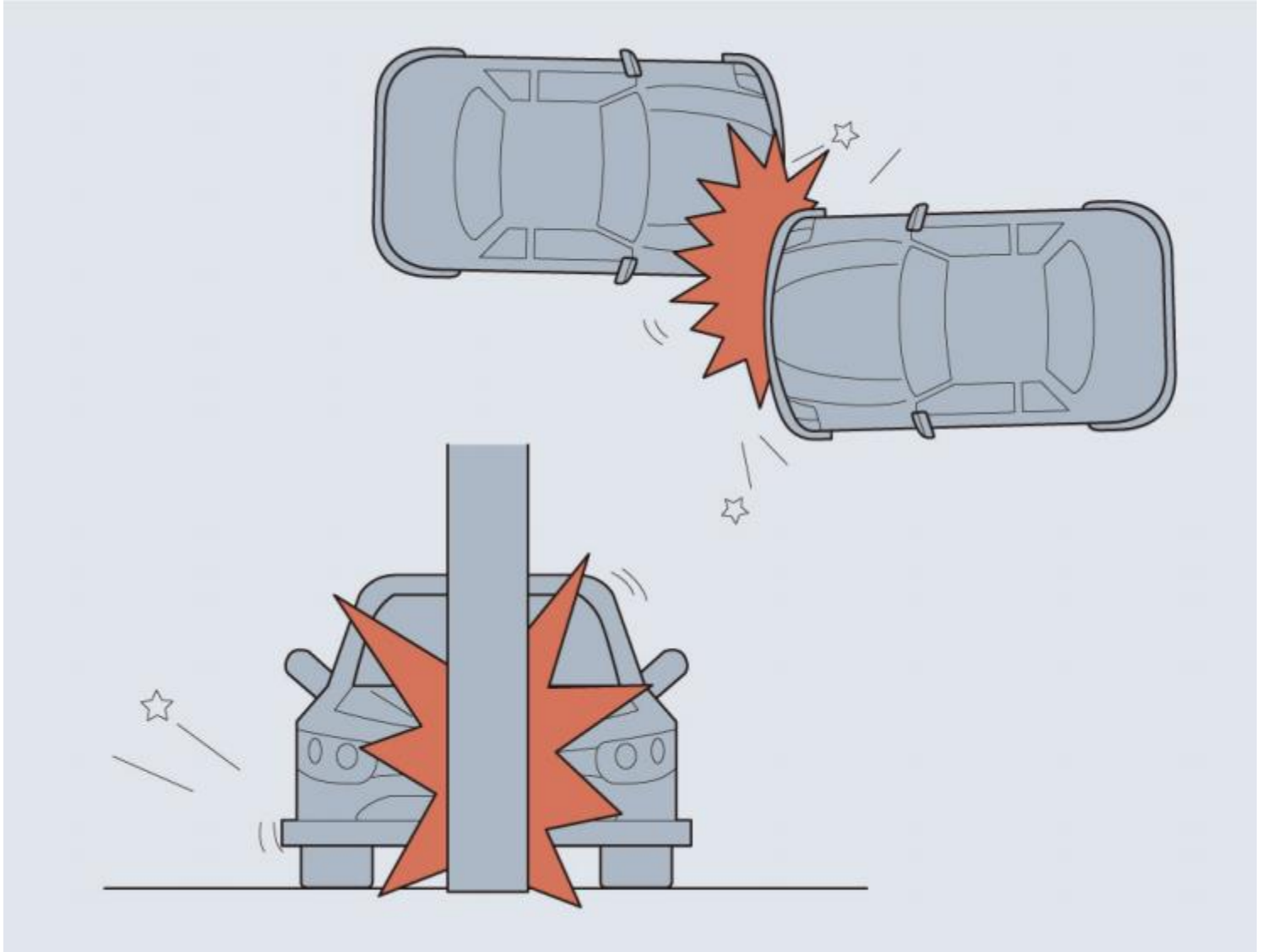

- The impact is with the bottom part of the tailgate of a truck; running head-on into a truck or a vehicle with a higher chassis.
- Frontal collision at an angle with guard bars.

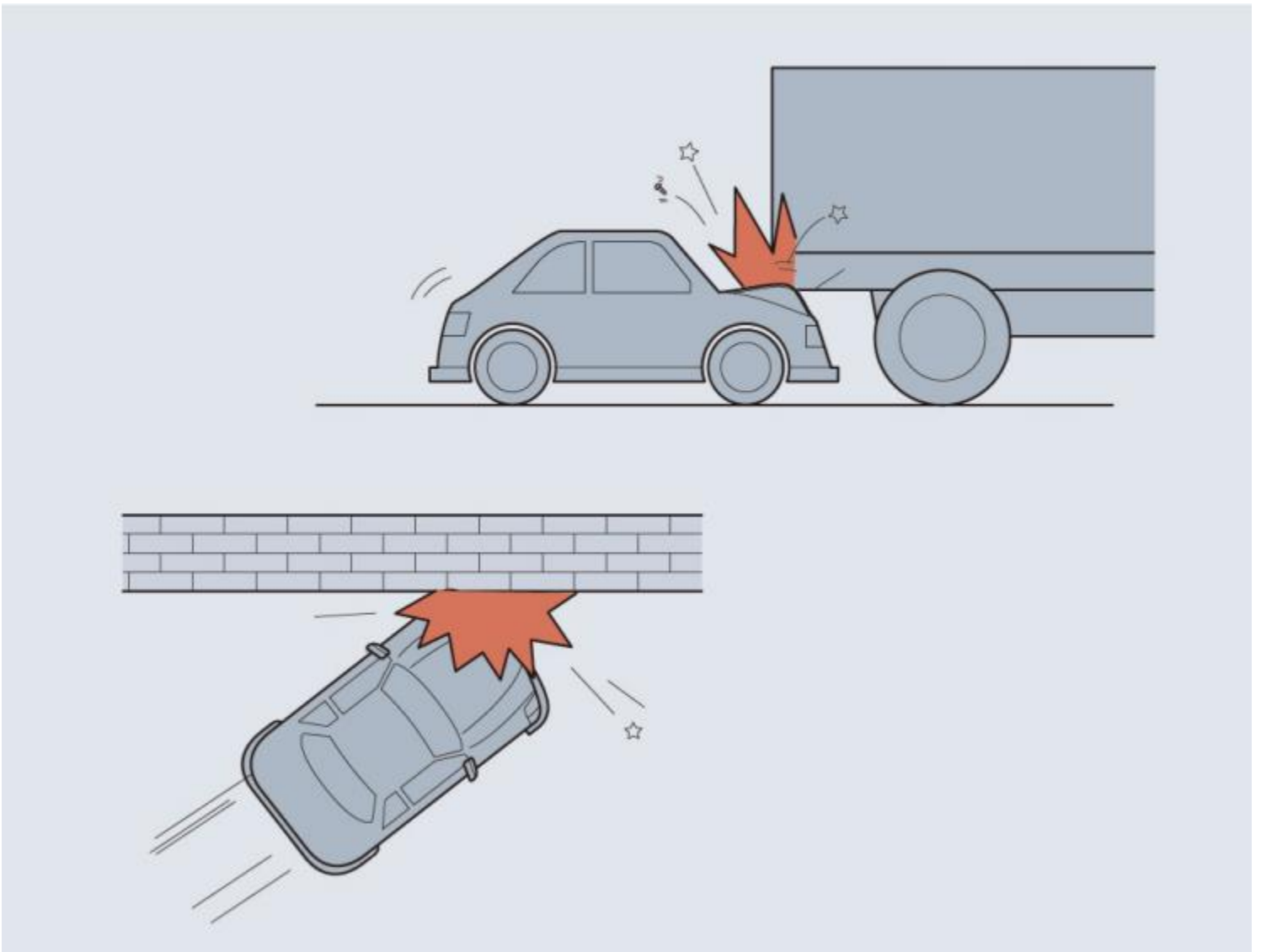

- Impacts to the rear or side of the vehicle.
- The vehicle rolling over.

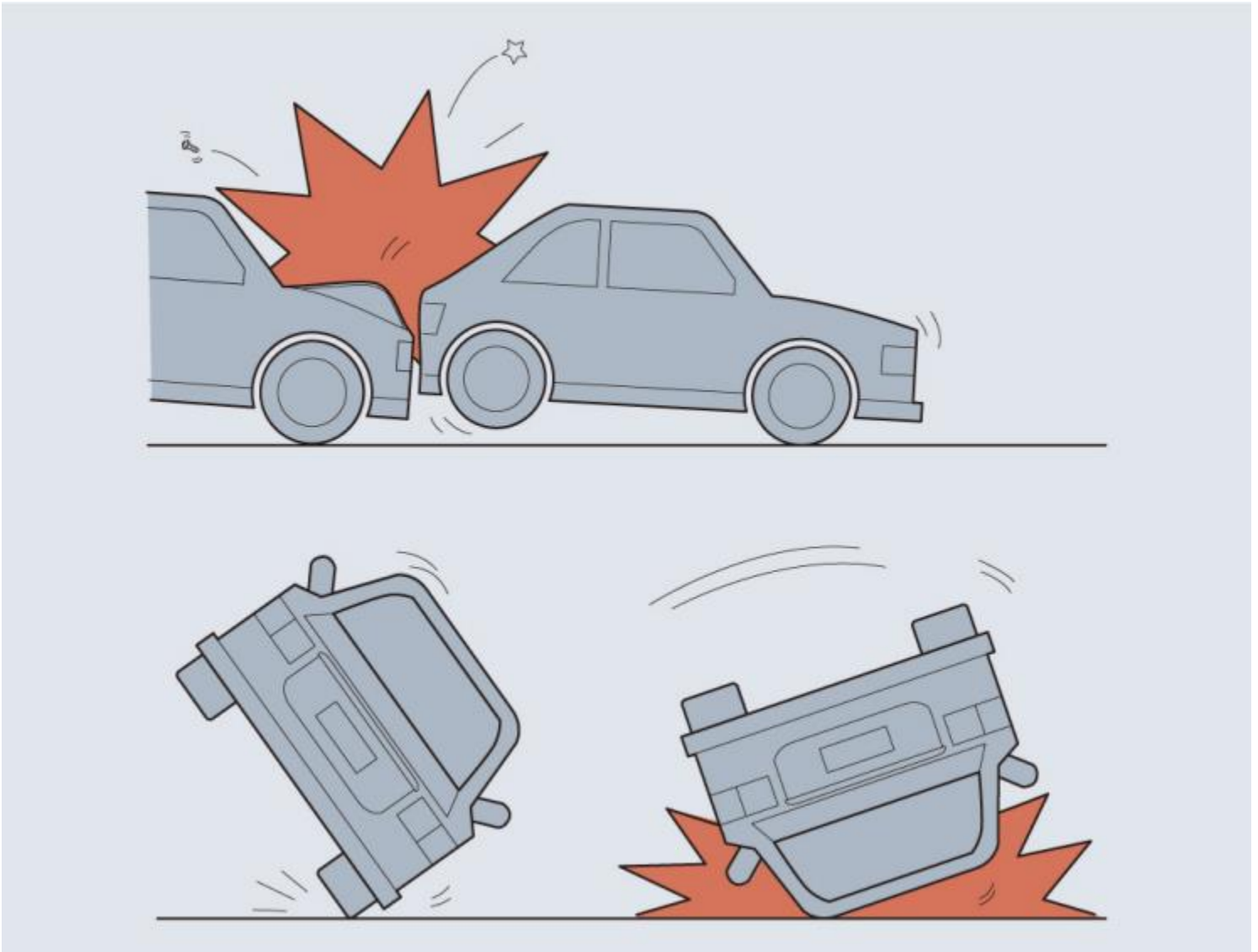

- Collision at an angle with the side of the vehicle.
- Side impact with a motorcycle.

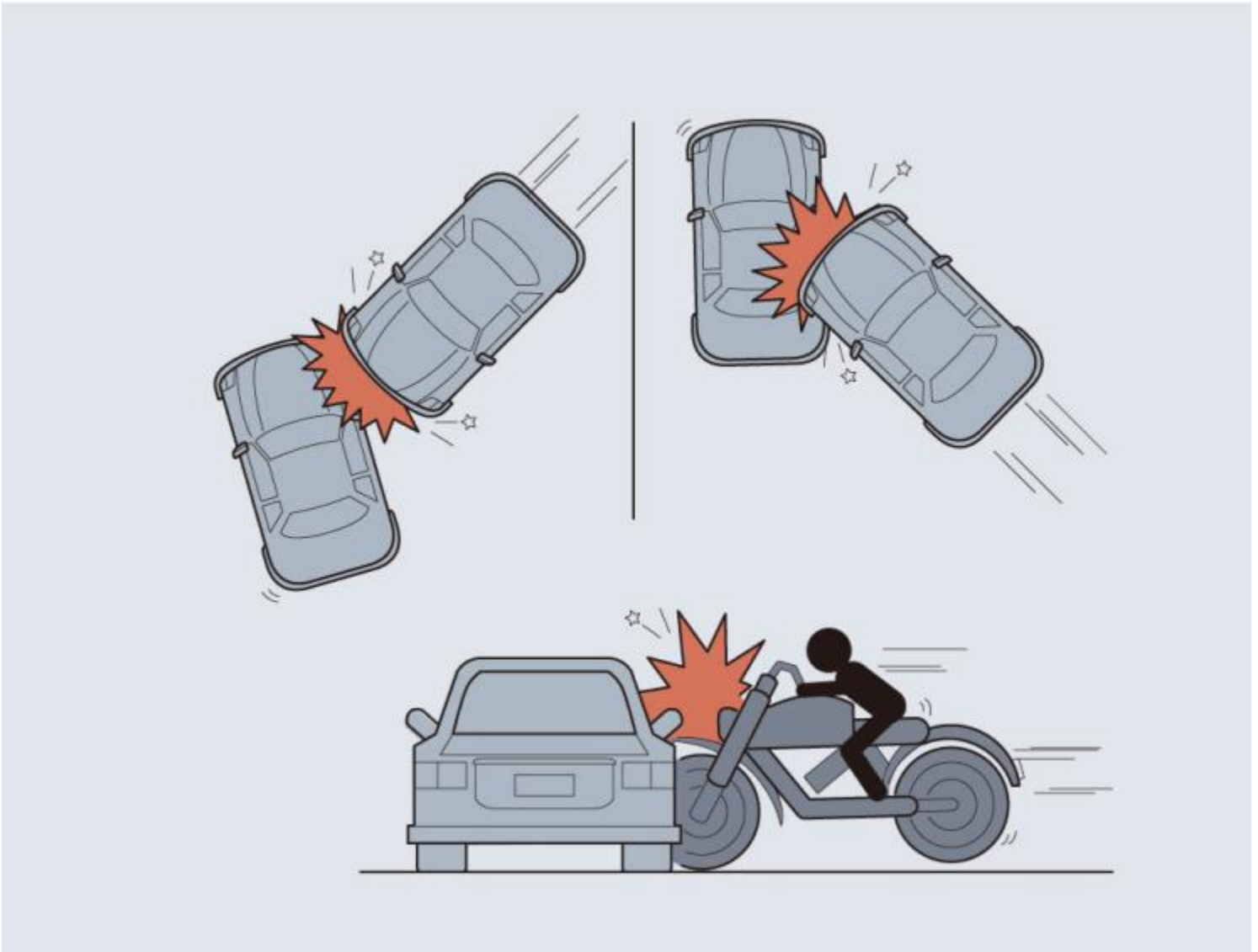

- Side impact on engine compartment.
- Side impact on boot.
- The vehicle rolling over.

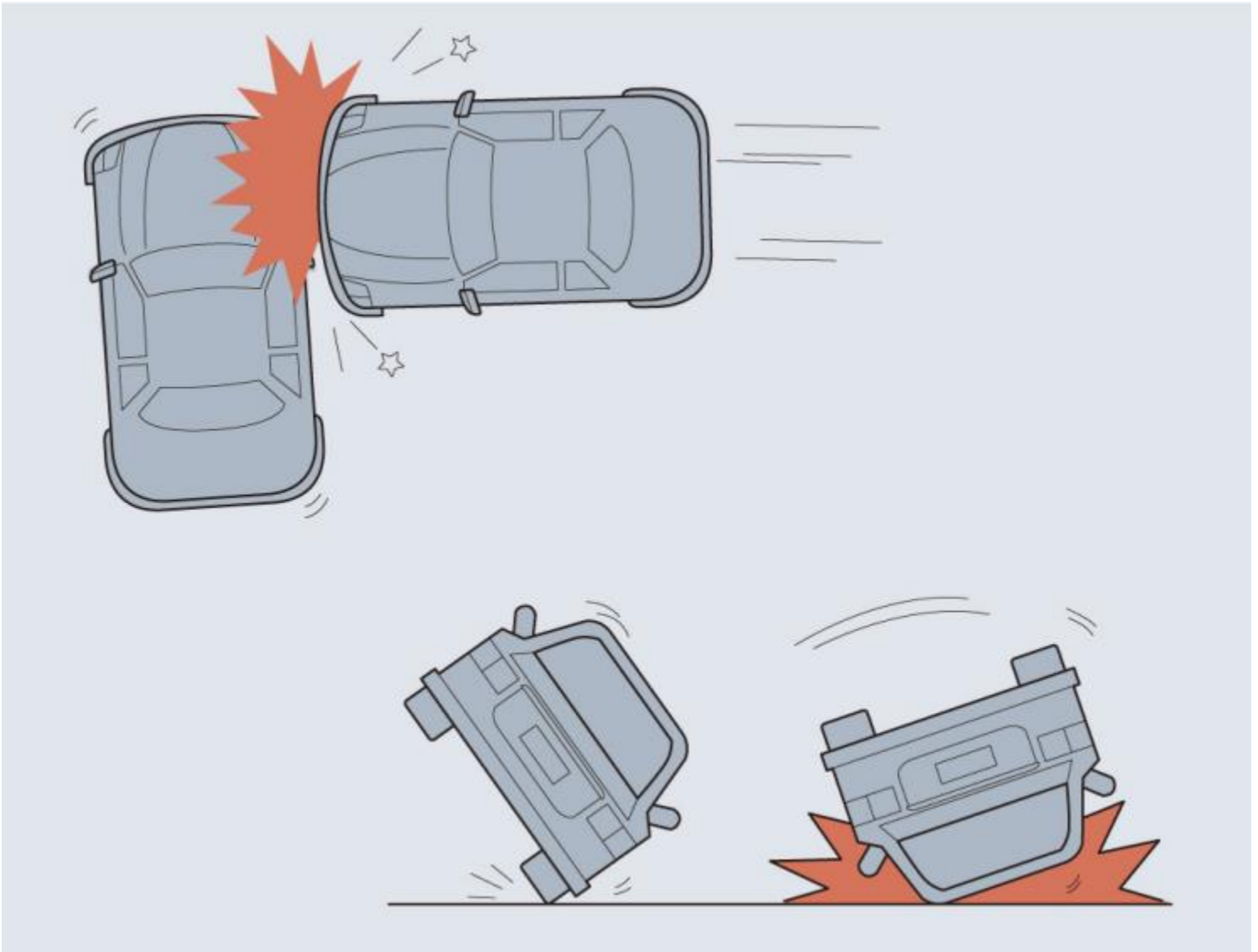

- Frontal collision at an angle with guard bars.
- Side collision with posts.

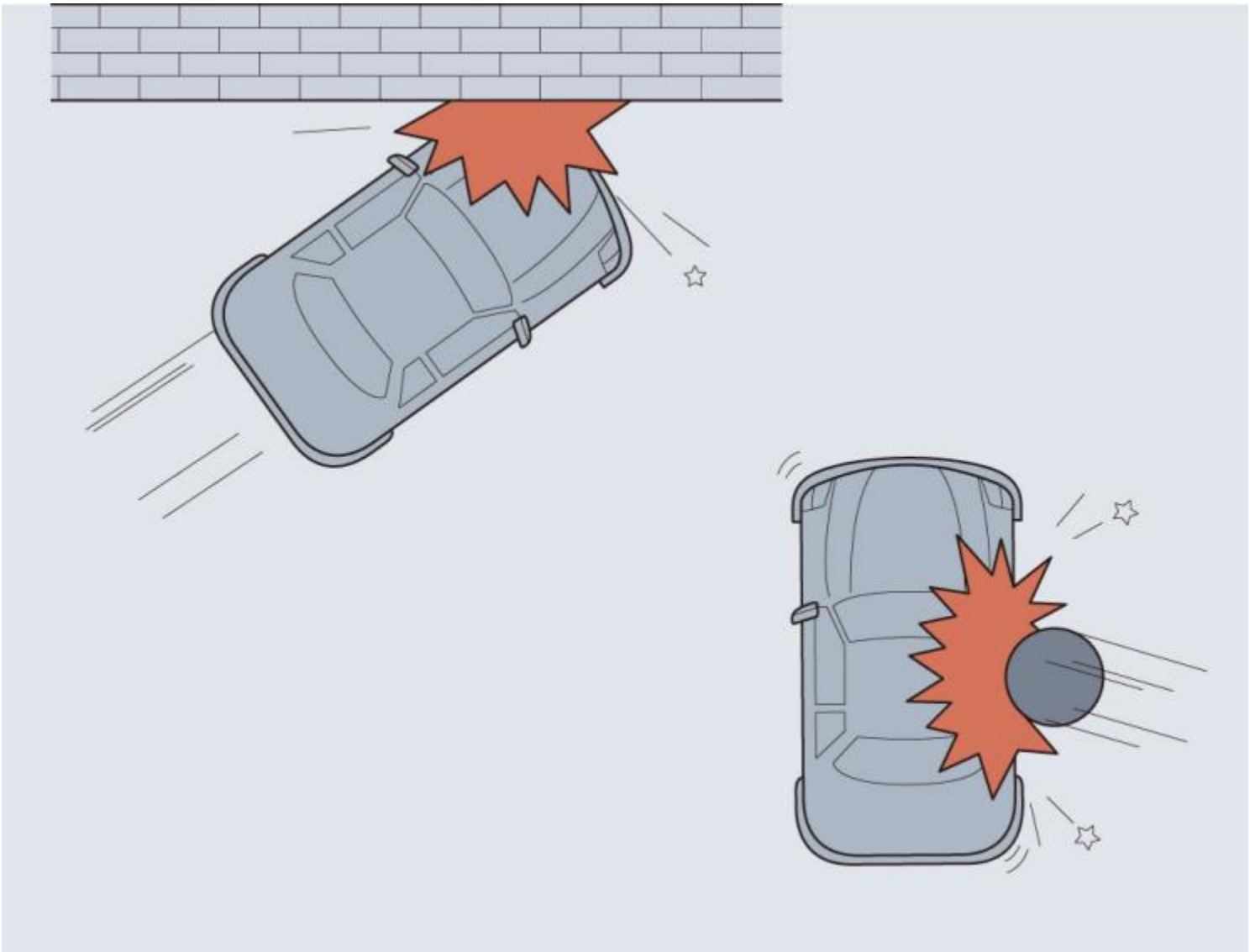

- Frontal collision with parking or moving vehicles.
- The impact is from the rear of the vehicle.

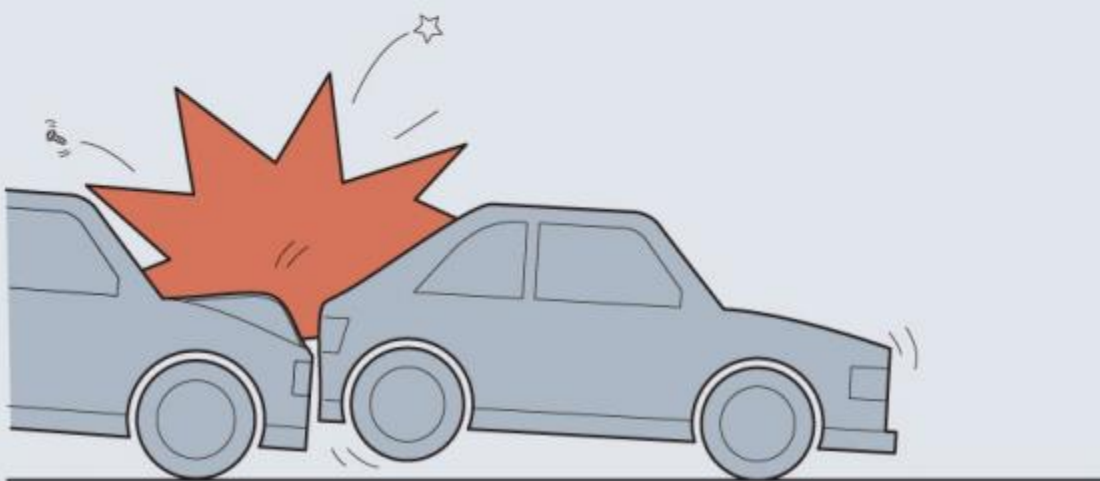
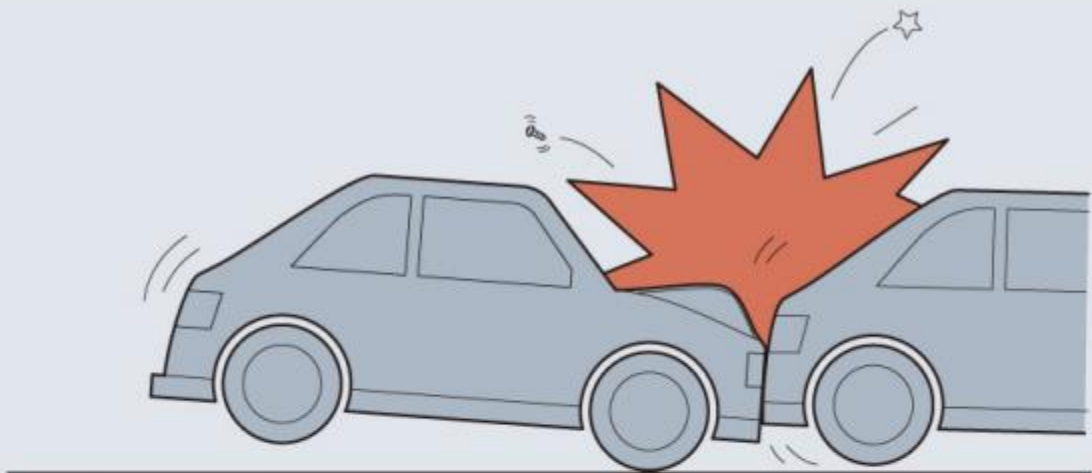

Service and Replacement of Airbags

Service of SRS components

Warning: Improper operation of the airbag may cause serious injury. DO NOT remove, maintain or alter SRS components or circuits without permission.

Warning: Changes to vehicle structure is prohibited. This may affect the normal operation of the SRS.

Warning: When cleaning the airbag trim cover, please use soft and dry cloth or cloth dipped with clean water.

Warning: DO NOT use any solvent or detergent, otherwise the normal function of the airbag system may be affected.

Warning: If water enters the vehicle, it may cause damage to the SRS. In this case, even if the collision does not occur, the airbag may accidentally deploy. Immediately shut down the engine and disconnect the battery cable. Contact an Authorised Repairer for service.

If the airbag warning light fails to illuminate or stays on, or if there is damage to the front or side of the vehicle, or the airbag covers show signs of damage, please contact an Authorised repairer immediately for checking the SRS.

IMPORTANT

- The service of SRS or the steering wheel must be carried out by professionals according to the technical specification and processes. For better guarantee of your safety, we recommend you consult an Authorised Repairer.
- After 10 years from the initial date of registration (or replacement of an airbag), it is recommended to replace the airbag assembly to guarantee your safety. If you have any doubt about the device within this period, we recommend you consult an Authorised Repairer.

Replacement of SRS components

Airbags are designed for using once only. Once the airbag is deployed, you must replace the SRS components.

Warning: Even if the airbag does not deploy, collisions may cause damage to the SRS in the vehicle. Airbags may not function properly after damage, and can not protect you and other passengers when a second collision occurs, which may cause serious injury or even death. To ensure that SRS can function properly after collision, please go to an Authorised Repairer to check airbags and replace when necessary.

Disposal of Airbags

When your vehicle is sold, ensure that the new owner knows the vehicle is equipped with airbags, and is aware of the replacement date of the SRS.

If the vehicle is scrapped, the undeployed airbags may have potential risks, therefore, before the disposal, they must be deployed safely in a certain environment by professionals according to the technical specification and processes, during which relevant regulations must be strictly observed. Please consult an Authorised Repairer for more details.

Child Restraint

Important Instructions for Using Child Restraint

Children under the age of 12 years shall be seated in rear seats. Compared with adults, children's muscles and bones do not fully develop, so you need to use dedicated child restraints to protect children. Use child restraints in rear seats to protect children based on the child's age, height and weight.

Only child restraints that comply with relevant regulations or standards (such as EU regulations ECE-R44, ECE-R129, and Chinese standard GB27887-2011) are permitted to be used in this vehicle. When choosing a child restraint, check relevant marks or instructions about the weight range applicable for the child restraint and the usage message on it.

When installing and using a child restraint, it is necessary to comply with relevant laws and regulations, the instructions supplied by the child restraint manufacturer, and the instructions on children's safety in this manual.

The correct use of child restraints will greatly reduce children's injury risk in accidents or relieve their injury severity, and please pay attention to the followings when you use child restraints:

1. It is recommended that children shorter than 1.5 metres (or under 12 years of age) should use the appropriate child restraint, and cannot use regular seat belt, otherwise it may cause the abdomen and neck injuries.
2. Never let your children ride in unprotected case. Care should not be neglected because of children sitting on the child restraint.
3. Only one child may be carried in any one restraint.
4. DO NOT put the child (including infant) on the lap or in arms when sitting in any seat.
5. Proper child restraint can provide protection for your children.
6. Relevant front seat may need to be adjusted frontward for installing the rear-facing child restraint to the rear seats.
7. Never let your child stand or kneel on the seat during driving, otherwise, your child may be tossed and thus lead to injury to their own and other people or even death when an accident occurs.
8. If a child's body is forward or the posture is not correct during driving, then the accident will increase the risk of injury.
9. The method of using seat belts has a great influence on the maximum protection offered by the seat belt. You must comply with the child restraint manufacturer's instructions on proper use of seat belts. If seat belts are not properly fastened, even a minor traffic accident may lead to injury.
10. Child restraints that are not fitted and secured correctly may move and injure other occupants in the event of an accident or emergency braking. Therefore, even if there is no infant or child in the child restraint, it should be fitted properly and securely in the vehicle.

Warnings and Instructions on Use of Child Restraint on Front Seat

Warning: DO NOT install the rear-facing child restraint to the front passenger seat, otherwise it may cause serious injury or even death to the child.

Warning: Sharing the same belt among children is never allowed. Children will huddle and be seriously injured in case of accidents.

 警告 WARNING	
<p>Do not place rear-facing child restraint on the front seat with airbag, otherwise it may cause serious injury or even death.</p> <p>里切古</p> 	<p>Always use the seat belt correctly. Child restraint must be used correctly and installed in the rear seat for children during driving. Never place any items above the airbag or between the airbag and yourself. If a side airbag is equipped, do not install any accessories on the side or near the side airbag. Refer to the Owner's Handbook for further information and instructions.</p>

Please carefully read the safe driving warning label on the sun visor. Always install the child restraint in the rear seat for security reasons. And above warning shall be noted in a special case when the child restraint must be used on front passenger seat.

Side Airbags and Children's Safety

Warning: Children should not be allowed in areas where airbags may deploy, or there is a risk of serious injury.

Warning: Only recommended child restraints suitable for the age, height and weight of the child should be used and firmly fixed in the vehicle.

Warning: Do not place any items in areas where side airbags may deploy, or there is a risk of serious injury.

In the event of a side collision, the side airbags can provide better protection for the passenger. However, when the airbag is triggered, a very strong expansion force is generated. If the passenger's seating position is not correct, the airbags or items in the side airbag deployment area may cause injury.

Therefore, the proper child restraint shall be used to secure the child properly in the seat and the child's seating position shall be correct, ensuring that there is enough space between the child and the side airbag deployment region for the airbag to deploy without any hindrance, and thus provide the best protection.

Child Restraints Groups

Group 0/0+ Child Restraint

Warning: Never place a child restraint on the front passenger seat, severe injury or even death can occur.

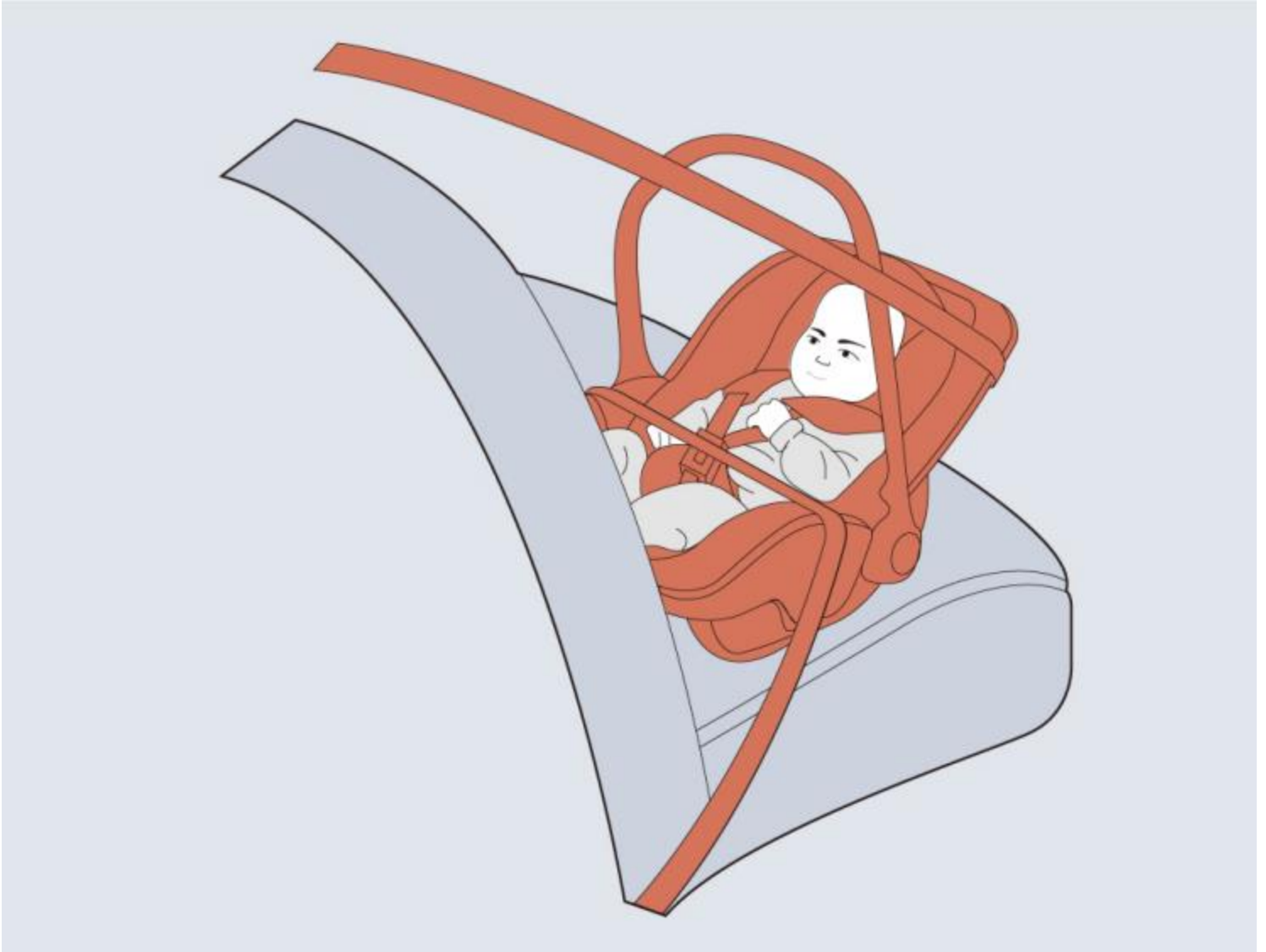

Rear facing child restraints that can be adjusted to lying position are most suitable for infants who are lighter than 10 kg (normally for those younger than 9 months) or those who are lighter than 13 kg (normally for those younger than 24 months).

Group I Child Restraint

Warning: Never place a child restraint on the front passenger seat, severe injury or even death can occur.



Rear or forward facing child restraints are most suitable for infants whose weight is 9 ~ 18 kg (normally for those older than 9 months and younger than 4 years old).

Group II Child Restraint

Warning: The diagonal section of the seat belt should pass across the shoulder and upper body, away from the neck. The lap section of the belt should pass across the hips of children, away from the abdomen. When necessary, tighten the seat belt slightly.



The combination of child restraint and lap-shoulder seat belt is most suitable for children whose weight is 15 ~ 25 kg (normally for those older than 3 years old and younger than 7 years old).

Group III Child Restraint

Warning: The diagonal section of the seat belt should pass across the shoulder and upper body, away from the neck. The lap section of the belt should pass across the hips of children, away from the abdomen. When necessary, tighten the seat belt slightly.



The combination of child booster seat and lap-shoulder seat belt is most suitable for children whose weight is 22 ~ 36 kg and whose height is below 1.5 m (normally for those about 7 years old or those older than 7 years old).

Child Restraint Installation Position

Only approved child restraints suitable for children are allowed. Children higher than 1.5m may directly use the seat belts in the vehicle.
 Applicability of Different Seating Positions to Child Restraints

Mass group	Seating positions		
	Front seat (without front passenger airbag switch)	Rear outboard	Rear centre
Group 0 (less than 10 kg)	X	U	X
Group 0+ (less than 13 kg)	X	U	X
Group I (9 ~ 18 kg)	X	U ¹	X
Group II (15 ~ 25 kg)	X	U	X
Group III (22 ~ 36 kg)	X	U	X

Note: explanation of letters in the table:

U = Suitable for universal child restraint systems approved for this mass group;

X = This seat position is not applicable to child restraint for this mass group.

Applicability of Different Seating Positions to ISOFIX Child Restraints

Fixing position		Mass group					
		Group 0	Group 0+	Group I		Group II	Group III
		Rear-facing		Forward-facing	Rear-facing	Forward-facing	Forward-facing
		Up to 10 kg	Up to 13 kg	9 ~ 18 kg		15 ~ 25 kg	22 ~ 36 kg
Front passenger seat	Size class	No ISOFIX Equipped					
	Type of child restraint						
Rear outboard ISOFIX position	Size class	C, D, E ¹	A, B, B ¹		C, D ¹	-	-
	Type of child restraint	IL ²	IL, IUF		IL	IL ³	IL ³

Rear centre seat	Size class	No ISOFIX Equipped
	Type of child restraint	

Note: explanation of letters in the table

IL = suitable for particular ISOFIX child restraints of the semi-universal category. Please refer to the vehicle list recommended by child restraints manufacturer;

IUF= suitable for forward-facing ISOFIX child restraints of universal category approved for use in this mass group and ISOFIX size class;

¹ The ISOFIX size class for both universal and semi-universal child restraints is defined by the capital letters A to G. These identification letters are displayed on the ISOFIX child restraints;

² When installing the child restraints, make sure that the seat belt lap strap is around the lap strap retaining clip.

Secure Child Restraints with Seat Belt

Warning: Never place a rear-facing child restraint on the front passenger seat, severe injury or even death can occur.

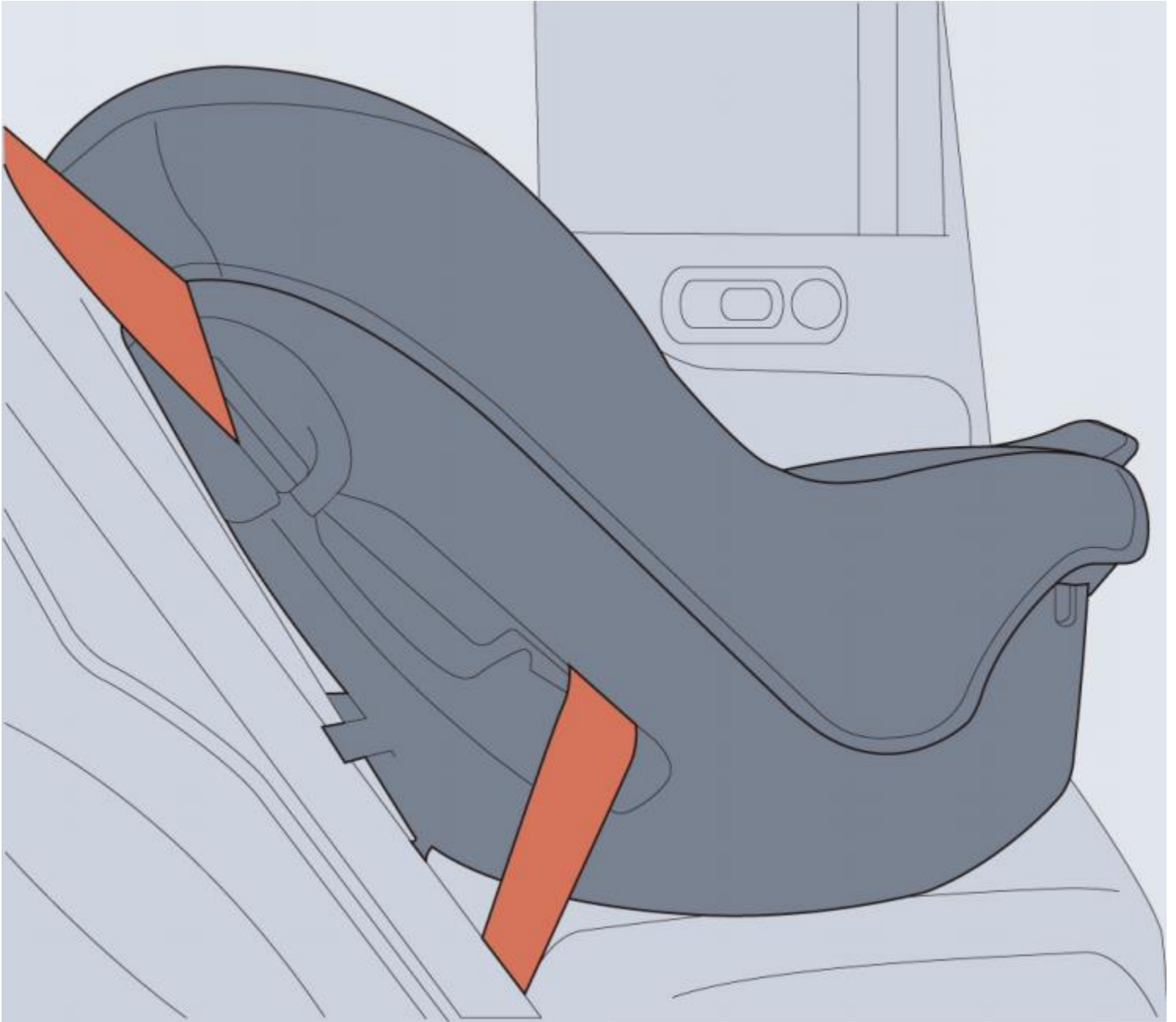

Please install the child restraint on rear seats, and fix it with lap-shoulder belt.

Secure Child Restraints with ISOFIX Device

Warning: The ISOFIX lower anchor is developed for the child restraint with an ISOFIX attachment. Therefore, do not secure other child restraint belts or items to the anchor. Or it will endanger your life.

Warning: Top-tether is designed to withstand only those loads imposed by correctly installed child restraint. Under no circumstances are they to be used for adult seat belts, harnesses, or for attaching other devices or items to the vehicle.

The rear seats at both sides of this vehicle are provided with ISOFIX interfaces connected to the ISOFIX child restraint. The interface is at the joint of the backrest and seat cushion, with ISOFIX mark provided on the relevant position (as arrowed in the figure below). Where possible always install child restraints on the rear seat. When installing and removing any child restraint system, always follow the manufacturer's instructions.

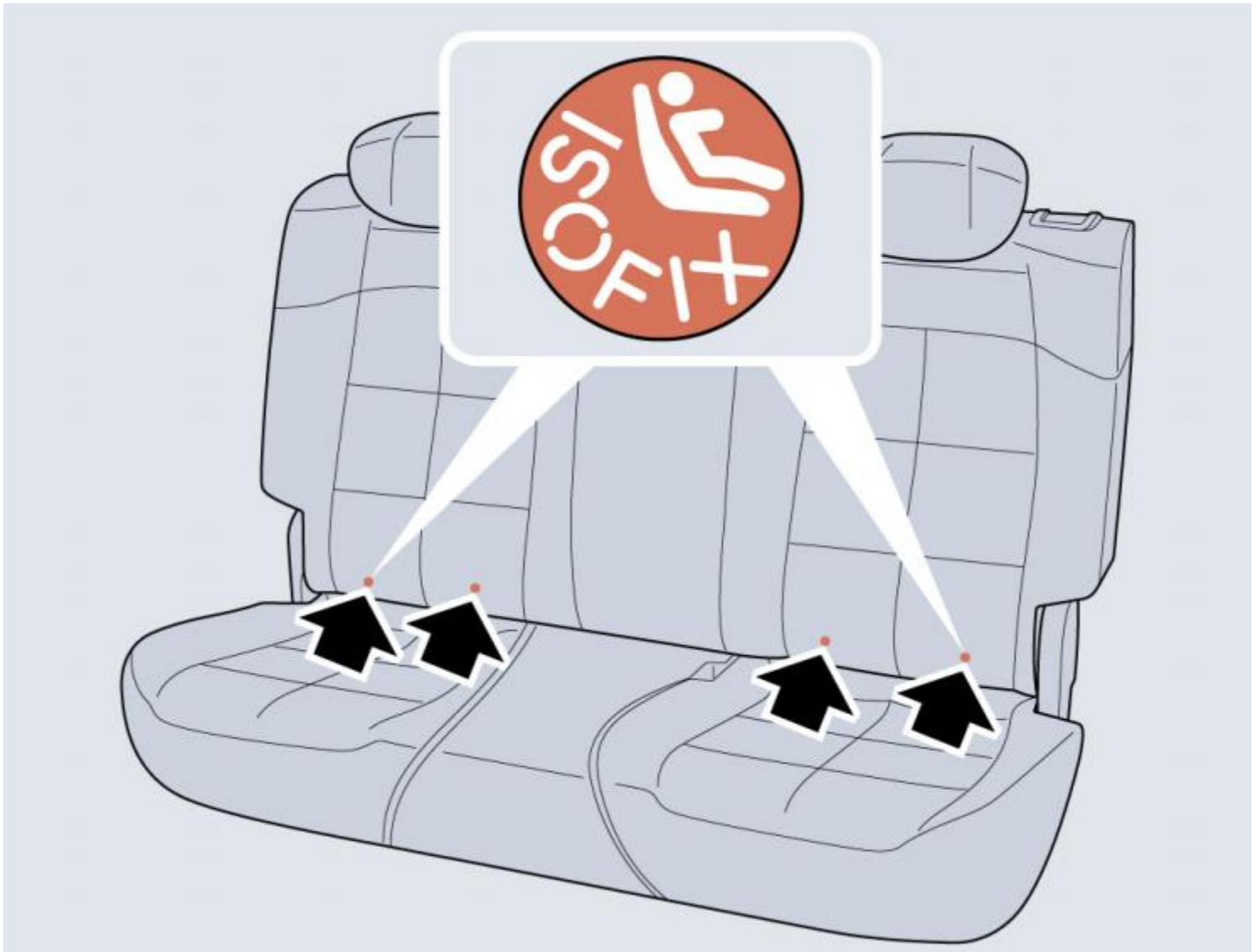

1. Insert the tapered plastic sleeve into ISOFIX anchor between the seat cushion and backrest.
2. Push the ISOFIX attachment of the child restraint into the tapered plastic sleeve already fitted, and snag it in the ISOFIX anchor.

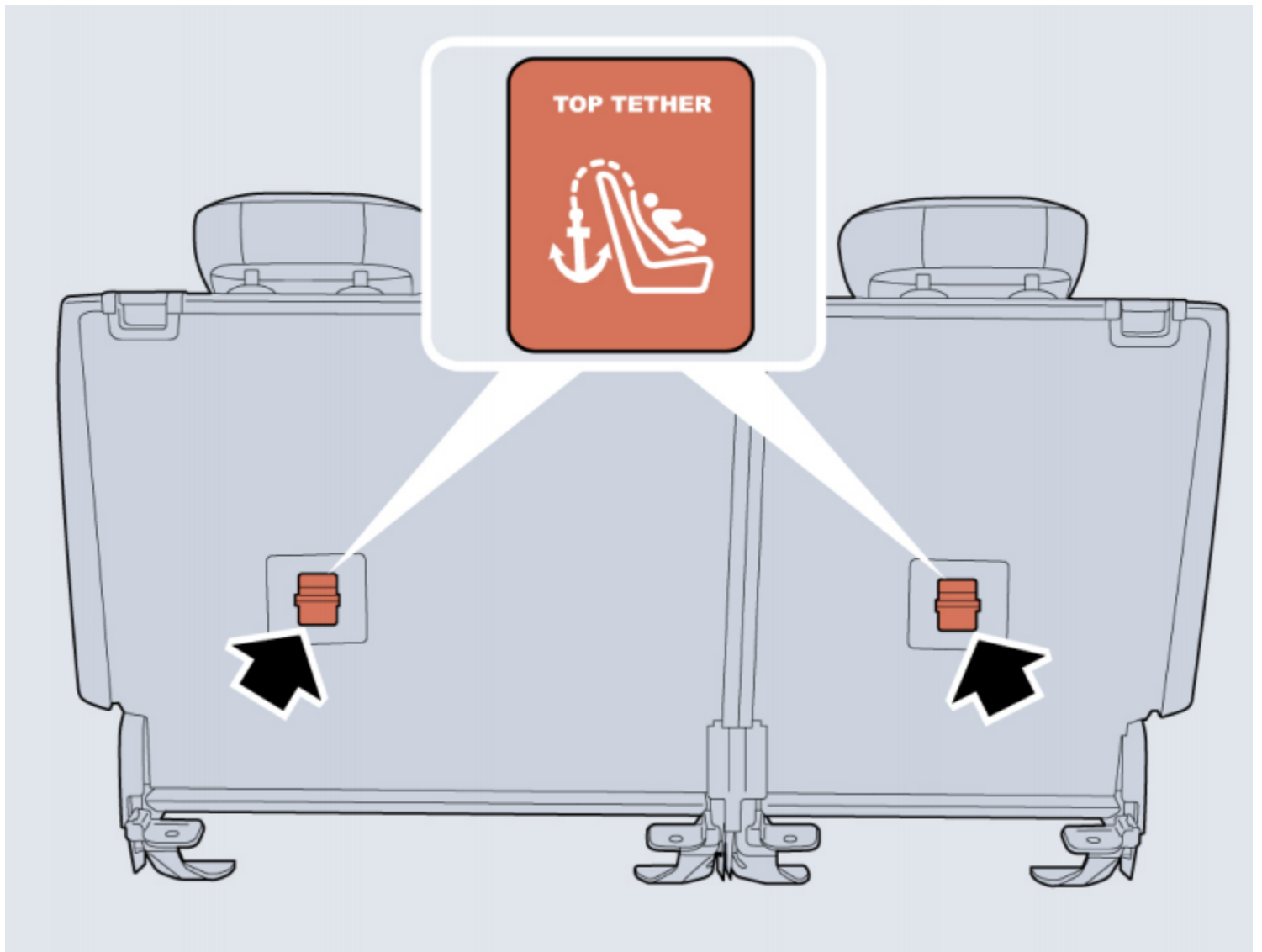

3. The top-tether (as arrowed in the figure above) for auxiliary fixation of the child restraint is provided at the back of the rear left seat backrest and at the bottom of the rear right seat.

Note: When installing a child restraint with top-tether, the top-tether must be connected with and fixed to the top-tether anchor.

4. After the installation, push or shake the child restraint with moderate force to confirm it is properly secured.

Gear Shift and Driving

Gear Shift

Warning: Do not press P gear button during driving.

Warning: During driving, do not move the shift lever from D to R or P gear, otherwise the damage to electric drive unit or dangerous accident may occur.

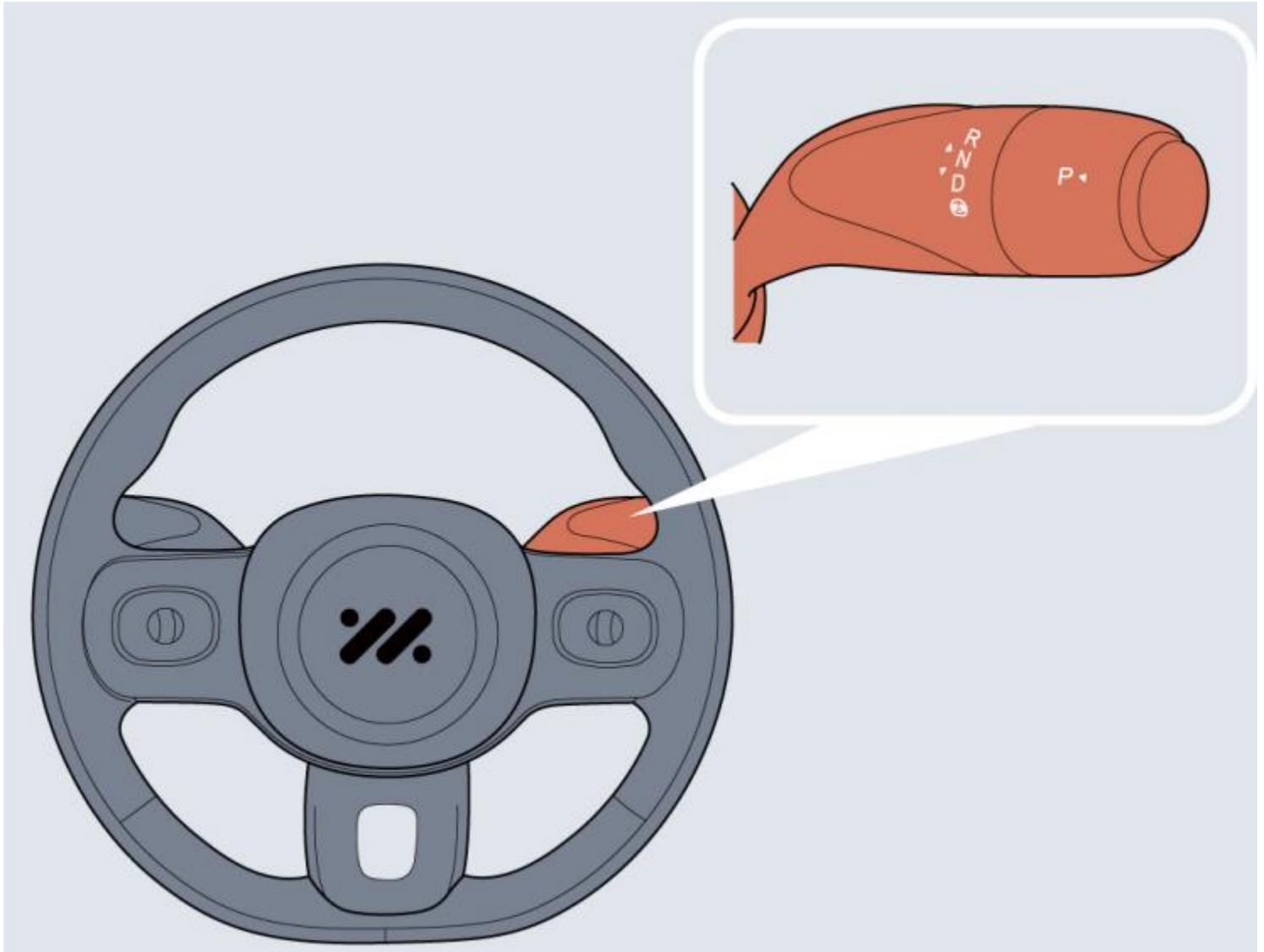

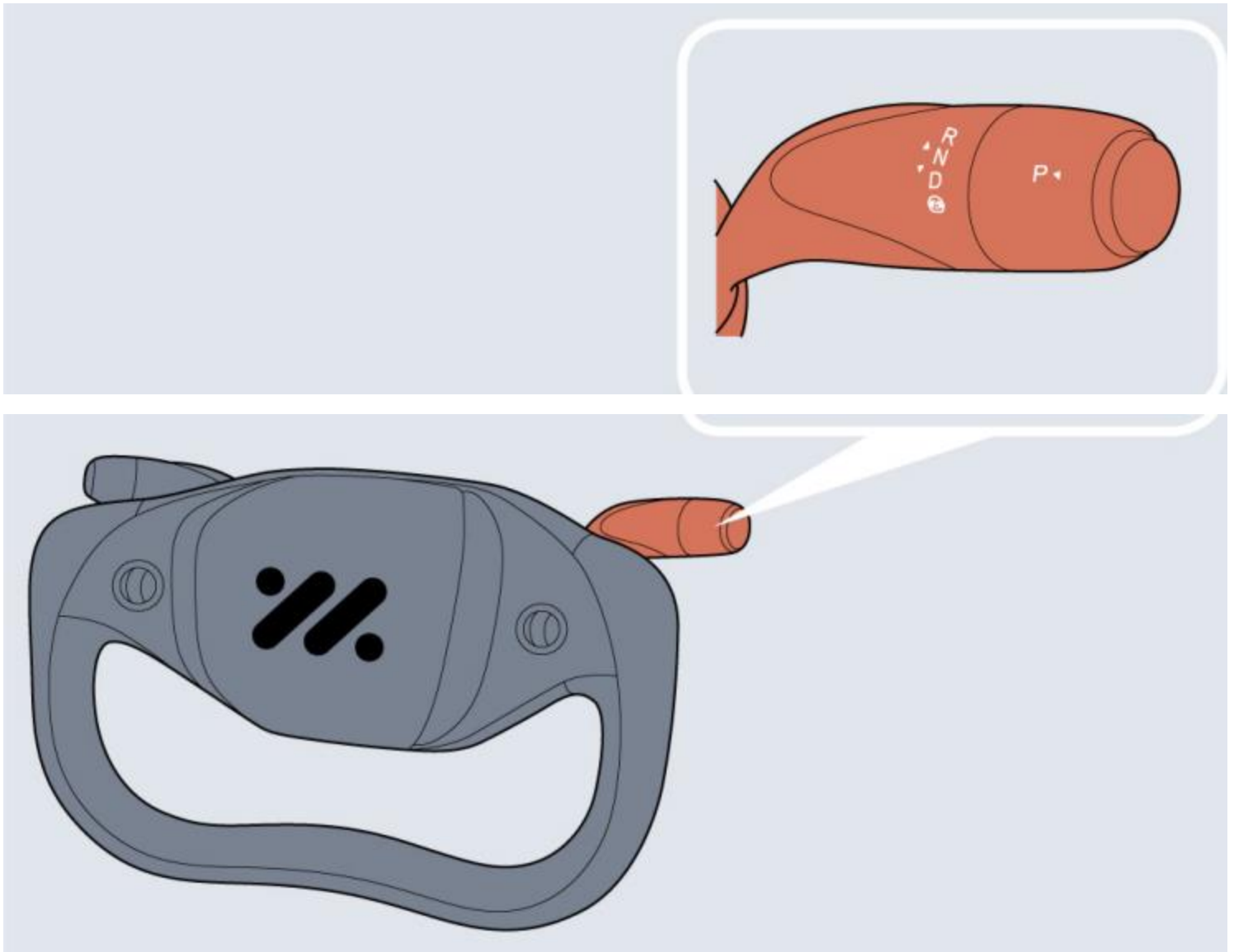

The shift lever is in the middle steady-state position, and shifting up or down will provide two non-steady-state positions.

P: Park

In this position, the vehicle will be locked. Please select this gear when the vehicle is stationary.

- Press the P gear button at the top of the shift lever to shift into P gear.
- Turn off the power supply, and the vehicle will automatically shift into P gear.
- With the brake pedal released, the driver seat belt unfastened and the driver's door open, the vehicle will shift to P gear automatically.

The initial gear after the vehicle is started is the P gear. When switching to R, D and N gears, the brake pedal needs to be depressed.

R: Reverse

This gear is selected only when the vehicle is completely stationary and the driver has a willingness to drive backwards.

Depress the brake pedal, turn the shift lever up to the end, and the vehicle will shift into Reverse gear.

N: Neutral

Select this gear when the vehicle is stationary (for example, waiting for traffic lights).

- With the vehicle in P gear, depress the brake pedal, turn the shift lever up or down to the first non-steady state position, and the vehicle will shift into Neutral gear.
 - With the vehicle in D gear, turn the shift lever up to the first non-steady state position, and the vehicle will shift into Neutral gear.
- Note: When the speed is more than a certain value, and the vehicle is switched from D gear to N gear, it shall be kept in N gear for 1s to shift into N gear.

- With the vehicle in R gear, turn the shift lever down to the first non-steady state position, and the vehicle will shift into Neutral gear.

D: Drive

It is used for normal running.

- With the vehicle in P/R/N gear, depress the brake pedal, turn the shift lever down to the end, and the vehicle will shift into Drive gear.

Energy Recovery during Coasting

Warning: Deceleration caused by energy recovery is not a substitute for braking required for safety. Always prepare for braking to ensure safe driving.

When the vehicle is in coasting state, the energy recovery function will be activated, and the motor will convert part of the kinetic energy of the vehicle into electric energy, which is then stored in the high-voltage battery.

Energy cannot be regenerated or the regeneration is restricted under the following conditions:

- The vehicle is in N gear (It is recommended not coasting in N gear while driving);
- During torque intervention (gear shifting, tyre skidding, etc.);
- High-voltage battery is fully charged;
- High-voltage battery temperature is too high or too low.

Through Central Screen - Settings - Controls - Energy Recovery or Central Screen - Settings - Driving - Energy Recovery, you can set the following 3 energy recovery modes in the coasting state.

OFF: Energy recovery is turned off.

LOW: Less energy is regenerated, with long coasting distance.

STANDARD: More energy is regenerated, with short coasting distance.

Driving Mode

Warning: Switching the driving mode when the vehicle is in motion can divert driver's attention from road conditions and may result in accidents.

Driving mode enables different tuning modes for power, brake, steering, suspension, instrument style, ambient light, active intake grille, etc.

Through Central Screen - Settings - Driving, you can select Comfort Mode, and Energy-saving Mode, Sport Mode, Snow Mode* and Personalized Mode*.

- Comfort Mode: It combines economy, power and comfort, and meets the daily driving needs of users.
- Energy-saving Mode: It runs with optimal energy consumption and extends driving range.

Note: In Energy-saving Mode, the vehicle offers the option of Super Energy Saving Mode, which allows for longer driving range by limiting intelligent drive, A/C power, turning off electrical appliances such as ambient lights, multimedia and displays.

- Sport Mode: The vehicle obtains more power and improves riding ability in complex conditions.
- Snow Mode*: The vehicle runs under AWD to provide more stable driving feel in combination with the systems.
- Personalized Mode*: The user can customize power, brake, steering, suspension and other systems.

When the vehicle is in Drive gear, the powertrain will switch between 2WD and 4WD modes according to the actual conditions and the selected driving mode. In Energy-saving Mode, 2WD is preferred; in Sport Mode, 4WD is preferred.

Environmental-friendly Driving

Running-in

The brake and tyres need time to 'bed-in' and adjust to the demands of everyday motoring. To enhance the long-term operation performance, try to avoid rapid acceleration or emergency braking during the first 1,500km.

Economical Driving and Maintenance

Environmental Protection

Your vehicle has been designed with the latest technology in order to minimize hazards to the environment.

Economic Driving

The way in which you drive your car has a significant bearing on the life span of the car, as well as affecting the electricity consumption:

Drive Smoothly

Traveling at a suitable constant speed is more electricity saving than frequent braking and acceleration. Avoid making hard acceleration, sudden start-off and emergency brake. Steady acceleration or deceleration uses less electricity than rapid acceleration or emergency braking, and minimizes the wear to mechanical components.

Avoid Driving at Maximum Speed

Both electricity consumption and noise levels increase significantly at high speeds.

Drive Foreseeingly

Avoid roads with traffic congestion or traffic jams. Foresee road congestion as early as possible and keep enough distance to the front car during driving, and slow down in time. Avoid stamping on the brake pedal for a long time if there is no braking need, which will cause friction plate premature wear.

Proper Use of Auxiliary Electrical Equipment in Car

Although it is essential to keep comfortable interior environment, the use of interior auxiliary electrical equipment will increase electricity consumption.

Check Tyre Pressures Regularly

Over or under-inflated tyres wear out more rapidly and also have a detrimental effect on the car's handling characteristics. Under-inflated tyres increase the rolling resistance of the car which, in turn, increases electricity consumption.

Do not Carry Unnecessary Loads

The accessories' weight and unnecessary loads consume more electricity, especially in stop/start conditions where the car is frequently required to set off from stationary. Avoid sticking mud, etc. to vehicle chassis, which not only will reduce body weight, but also can prevent body corrosion.

Maintain Correct Four-Wheel Alignment

Avoid collision with the kerb and reduce speed on uneven road surfaces. Incorrect four-wheel alignment not only will cause premature tyre wear, but also will increase power load and electricity consumption.

Driving in Special Environment

Driving in Rainy or Snowy Days

Warning: Emergency braking, acceleration and sudden turns on slippery roads will lead to tyre slip and reduce vehicle controllability to cause accidents.

- Because the visibility is poor in rainy or snowy days, please drive carefully. If the windows are fogged, please use the air-conditioning defog function.
- Because the roads are slippery in raining, please slow down and drive carefully.
- Try to avoid driving at high speed in rainy or snowy days, because a water film will be formed between tyre and road surface to affect steering and braking performance.

Driving on Waterlogged Roads

Minimize driving on waterlogged roads or streams. After driving through puddles, please slightly depress the brake pedal to confirm the braking performance is normal. Wet brake pads cannot brake normally. If only brake pad at one side can brake normally, steering control may be affected to cause accidents. Moreover, the electrical system of the vehicle may be seriously damaged due to excessive moisture.

Braking and Parking

Integrated Braking System (IBS)

Pay attention to the followings during use of the integrated braking system (IBS) equipped on the vehicle:

1. The IBS only functions with the power system in READY mode or operational. NEVER allow the vehicle to freewheel with the power system turned off.
2. If the power system is turned off while driving, you should firmly press the brake pedal, and stop the vehicle as quickly as traffic safely permits. If necessary, please contact the Authorised Repairer for service.
3. If the IBS performance degrades due to a low battery or other reasons, you need to apply more force, usual to the brake pedal to brake effectively.
4. When driving on waterlogged roads or in heavy rain, a water film may form on the surface of brake disc, which easily reduces the braking efficiency and extends braking distance. In this case, keep a safe distance from other vehicles and intermittently apply the brake pedal to keep the brake disc surface dry.
5. If the braking efficiency decreases due to vehicle failure, please contact an Authorised Repairer for service as soon as possible.

Brake response mode

The system provides three brake pedal forces. When the vehicle is stationary, the user can customize the corresponding brake mode on the central screen as required.

1. Comfort: The braking response is moderate and the pedal feel is moderate.
2. Moderate: The braking response is normal and the pedal feel is normal.
3. Sport: The braking response is sensitive and the pedal feel is sensitive.

IMPORTANT

If the brake pedal is pressed or one of the Stability Control System (SCS)/Anti-lock Brake System (ABS)/Traction Control System (TCS) is triggered, the switching of braking response modes cannot be completed immediately.

Brake energy recovery

IBS supports brake energy recovery. When the brake pedal is pressed for braking, the system will determine the driver's demand for braking force. The drive motor will convert the vehicle's kinetic energy into electrical energy, which is stored in the high voltage battery for vehicle deceleration. This process can improve the range of the vehicle.

Parking Brake System - Electronic Parking Brake (EPB)

Warning: When EPB cannot be released due to failure, DO NOT move the vehicle with rear wheels in contact with the road surface, otherwise it may cause damage!

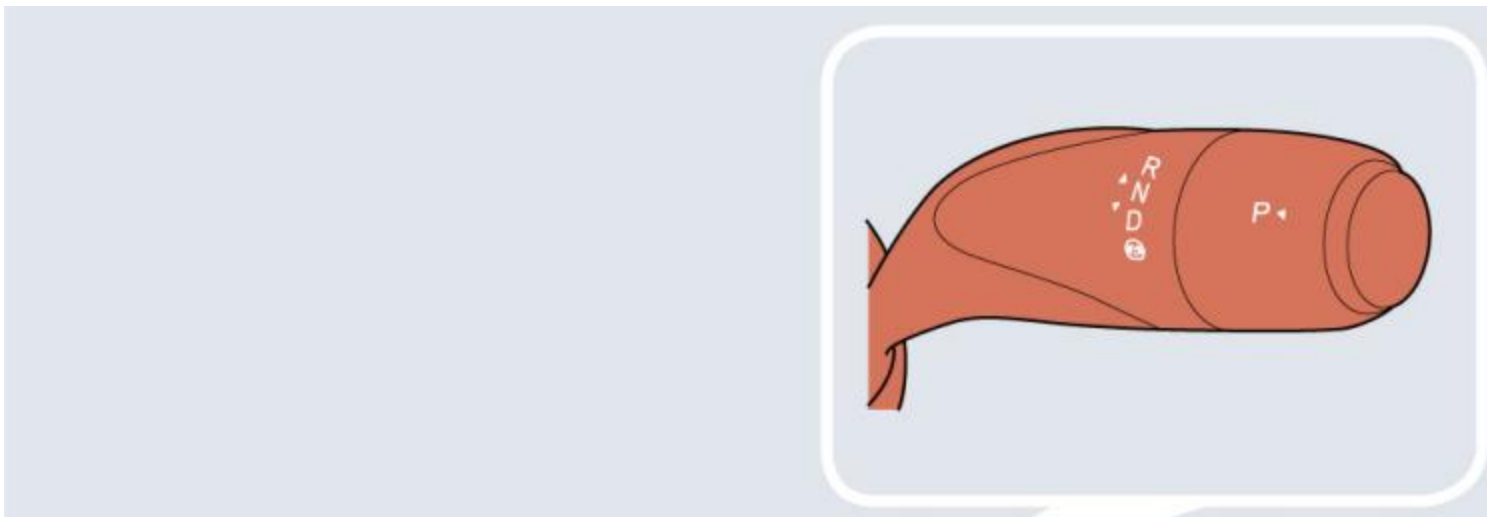
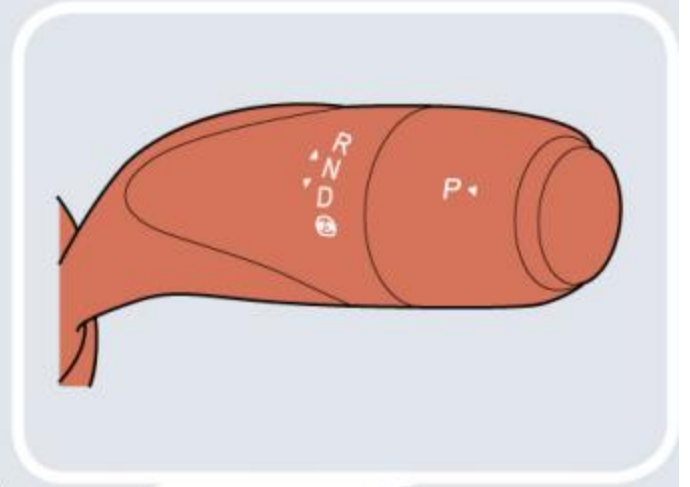
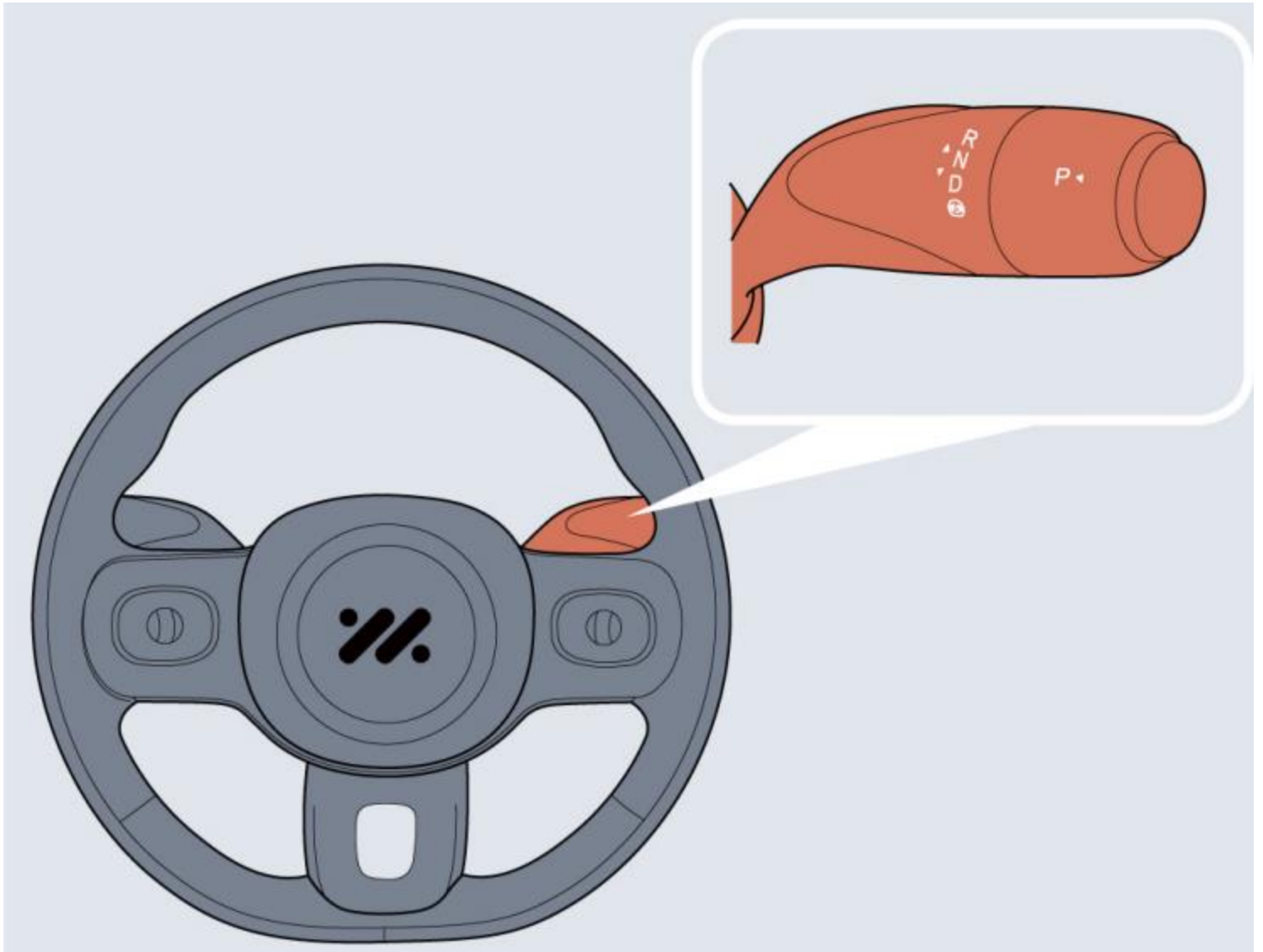

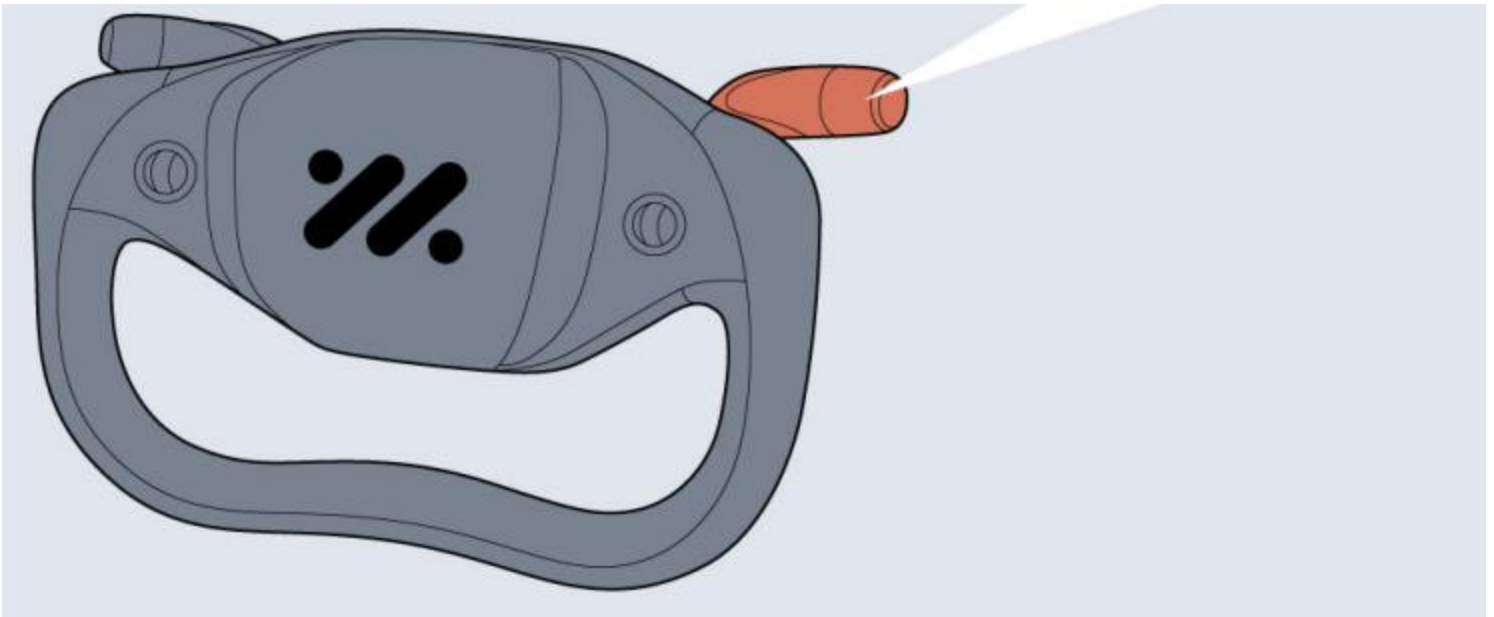

P gear for parking and EPB are triggered by the same switch. The motor noise may be heard when applying or releasing the EPB. When the vehicle is stationary, press the EPB switch to enable EPB. With EPB enabled, press the brake pedal to shift from P gear to other gears, and the EPB will be disabled. With EPB enabled and the vehicle not engaged in P gear, when the driver fastens seat belt, shifts to D or R gear, and depresses the accelerator pedal, the EPB will be disabled.

Note: Always turn on the EPB system every time you leave the vehicle.

IMPORTANT

- The EPB cannot be released when the vehicle fails to shift from initial P gear to other gears.
- In the event of a flat battery, it is not possible to apply or release the EPB. In such a case, a jumper cable shall be used for emergency vehicle start. Please refer to 'Jump Start' in 'Emergency Information' section.

Emergency Braking with EPB

Warning: Inappropriate use of the EPB for emergency braking may lead to accidents and injuries. Do not apply the EPB for braking the running vehicle, unless in emergency.

Warning: During emergency braking using the EPB, DO NOT switch off the power system, this could result in serious injury.

When the car is in motion, in case of any emergency, such as the car cannot be stopped by the brake pedal, it can be decelerated by long pressing the EPB switch.

Continuous audible warning will be heard during emergency brake for deceleration by long pressing the EPB switch. To cancel the emergency brake process, release the EPB switch.

Body Stabilization System (SCS)

The body stabilization system includes Dynamic Stability Control System (SCS) and Traction Control System (TCS).

SCS is designed to assist the driver in control of driving direction. When SCS detects that the vehicle is not moving in the intended direction, it will intervene by applying brake force to selected wheels or through the power system to prevent sliding and stabilise the driving direction by correcting the under-steering or over-steering.

TCS contributes to maintaining the control to the vehicle by improving the vehicle's traction trafficability and driving stability. TCS monitors the driving speed of each wheel individually. If spin is detected on one wheel, the system automatically brakes that wheel, transferring torque to the opposite, non-spinning wheel. If the driving wheels are spinning, the system will reduce the output torque of the power system in order to regulate wheel rotation until traction is regained.

Switching on/off

SCS and TCS are automatically enabled. In Driving Settings interface of the central screen, click the SCS button to enable SCS and TCS.

Note: Disabling SCS and TCS will not affect the normal operation of ABS. Always disable SCS and TCS when driving with anti-skid chains fitted.

Anti-lock Brake System (ABS)

Warning: The ability of ABS to quickly stop the vehicle will be limited at high speed or on road conditions with risk of coasting (such as waterlogged roads that prevent adequate contact between the tyres and the road surface). In all cases, it remains the driver's responsibility to drive within normal safety margins.

Warning: DO NOT pump the brake pedal at any time; this will interrupt the operation of ABS and may increase the braking distance. The ABS is mainly used to automatically adjust the braking force of the brake when braking to prevent the wheels from being locked, thus avoiding dangerous situations such as loss of direction or side slip during emergency braking.

This system enables the driver to maintain control over the steering in case of emergency braking, keeps the vehicle stable, and improves the safety factor.

Under normal braking conditions, ABS will not be triggered. However, if the braking force exceeds the adhesion of the tyres to the road surface, causing the wheels to lock, the ABS will automatically come into operation. This will be recognisable by a rapid pulsation felt through the brake pedal.

If emergency braking is required, the driver should apply full braking effort to trigger the ABS even when the road surface is slippery. ABS can ensure that the wheels cannot be locked.

Note: On loose gravel, loose soil or snow roads, the characteristics of the ABS system may extend the braking distance and even increase the steering force.

IMPORTANT

- Although ABS can greatly improve the driving safety, the real safety still depends on the driver's own standard driving behavior.
- The non-operation of the braking anti-lock brake system (ABS) in part or in whole will not affect the operation of the ordinary brake system.

Auto Hold

Warning: The auto hold system cannot necessarily stabilize the vehicle when starting off on the hill, or brake the vehicle when driving down the hill (such as on a slippery or icy road).

Warning: When auto hold stops the vehicle, but for some reasons such as shutting down the power system, unfastening the seat belt or pressing the auto hold switch, the electronic parking brake is applied. It cannot be guaranteed that the vehicle will be stabilised in all cases. For example, the rear wheels are on an icy, snowy or slippery road surface, or the slope of parking is high. Please make sure that the vehicle is safely stabilised prior to exiting.

Warning: The driver should pay full attention and observe the surroundings even if the vehicle is equipped with auto hold system.

Warning: Auto hold cannot guarantee the electronic parking brake operation in all cases where the power system is shut down. Please ensure the electronic parking brake is applied and the vehicle is stabilised prior to exiting the vehicle.

Warning: The Auto Hold must be switched off before the use of car wash device for automatic car washes, otherwise the EPB may suddenly apply and cause vehicle damage.

If the vehicle is required to stop frequently for long periods while driving (such as wait at the traffic lights, stop on a slope or in urban stop-and-go conditions), the Auto Hold function can assist you in stabilising the vehicle and prevent it from moving, enabling you to remove your foot from the brake pedal when the vehicle is stationary.

Auto Hold has three states as follows:

1. Standby: With the driver's seat belt fastened, the driver's door closed and the vehicle in READY state, press the Auto Hold button on the central screen to enter Standby state.
2. Operating: When the vehicle is moving forward, press the brake pedal to stop the vehicle, and then firmly press the brake pedal to switch the Auto Hold function from Standby to Parking state. The Auto Hold will exit the parking state if the brake pedal is firmly pressed again. When the Auto Hold is in parking state, it will exit the parking state according to the slope if D or R gear is selected and the accelerator pedal is pressed.
3. Press Auto Hold button on the central screen again to disable the function.

Note: If the vehicle is stopped by firmly pressing the brake pedal, the Auto Hold function will directly enter the parking state.

The Auto Hold will exit the parking state when the EPB switch is pressed with the brake pedal pressed.

The Auto Hold will exit the parking state under some circumstances such as releasing the seat belt, turning off the power system, remaining static for a length of time or touching the Auto Hold switch. At this time, the EPB will be applied.

Hill Hold Control (HHC)

Warning: It is impossible for HHC to hold the car when going uphill in any cases (such as wet, slippery or icy surfaces, etc.). The driver must always pay attention to the vehicle conditions.

Warning: DO NOT exit the vehicle with HHC applied, otherwise it may lead to a serious accident.

Warning: When starting on stop-and-go uphill conditions, please fully depress the brake pedal for a few seconds before each start-off. HHC assists the driver by holding the vehicle during hill starts. If the driver releases the brake pedal, the HHC will hold the vehicle stationary for a short time.

HHC will be activated when the following conditions are met at the same time:

1. Close the driver side door and fasten the seat belt.
2. The vehicle is stably parked on the road surface with certain slope.
3. SCS is fault free.
4. EPB is released and fault free.
5. The vehicle is READY.
6. The vehicle is in D or R gear.
7. Sufficient force has been applied on the brake pedal before start-off.

Note: When the vehicle is reversing upward on the slope, the HHC also works.

Emergency Hazard Warning Strobe (HAZ)

If the driver makes an emergency braking manoeuvre and certain conditions are met while driving, the brake lamp will automatically strobe to alert the drivers behind, thereby reducing the occurrence of rear-end collisions.

Note: With the hazard warning lamp turned on, the hazard warning strobe (HAZ) will not function.

After the HAZ is activated, when the emergency braking manoeuvre is exited, the HAZ will be switched off after a few seconds.

Note: If the vehicle speed is less than 10 km/h when the brake light strobe stops, the hazard warning lamp will illuminate automatically.

Short press the hazard warning lamp switch or speed up to above 20 km/h for more than 5s to turn off the hazard warning lamp.

Auxiliary Brake System

The auxiliary brake system consists of Electronic Brake Force Distribution System (EBD) and Electronic Brake Assistance System (EBA).

The EBD system can automatically distribute the braking force between the front and rear axles, so that the vehicle can have good braking performance under different load conditions.

When the brake pedal is depressed for emergency braking, the EBA will increase the braking force applied on each wheel while assisting the driver in quickly triggering ABS, thereby shortening the braking distance.

Hill Descent Control (HDC)

Warning: HDC is just an auxiliary function, and cannot ensure the vehicle drives down the steep slope at a low speed in all conditions, such as slippery ground, snowy road surface or steep slope, etc.

Warning: Even when HDC is in use, the driver still has to pay close attention to the driving state of the vehicle, and take active control when necessary. Because in certain cases, HDC may remove itself from the operating state temporarily.

Warning: Under some driving conditions on downhill surfaces (e.g. driving down a slope with high speed, small slope, etc.), HDC is inoperative, so the driver shall be required to control the heating the speed by depressing the brake pedal to ensure the safe driving.

HDC system is an auxiliary function designed for vehicles running on acute downhill surface. It reduces the speed by applying the brake force, thus assists the driver to drive on acute downhill surface smoothly.

Note: When the HDC is working, it is normal for the brake system to generate slight vibration or working noise.

Note: When the HDC is working, do not shift to N gear, since this operation will deactivate the HDC function.

HDC is off by default. After the vehicle is powered on, the function can be enabled by using the HDC button on the entertainment display.

HDC system has four states as follows:

1. **Standby:** touch HDC button to enable the function and enter into standby state.
2. **Operating:** In Standby mode, when the vehicle drives on the acute downhill surface at low speed, if the driver does not depress the brake pedal or the accelerator pedal, HDC automatically enters the Operating state. Meanwhile it may be accompanied by the working noise of the brake system, and the vehicle drives down the acute downhill surface smoothly.
3. **Temporary Deactivation:** Depress the accelerator pedal or brake pedal to a certain extent in Operating state, HDC will temporarily remove itself from the operating state.
4. **OFF:** Touch HDC button again to disable HDC.

Note: When the vehicle steers suddenly on the hill with a certain gradient, HDC may switch from Standby state to Operating state.

Digital Video Recorder (DVR)

Instructions for Use

- 1 When using it, please clean the windscreen first to ensure the quality of video recording.
- 2 In bad weather (such as rain, snow, fog, smoke, dust, haze, frost, etc.), when visibility is low, the quality of recorded image may deteriorate.
- 3 DO NOT operate the digital video recorder (DVR) or watch the video when the vehicle is running, so as not to affect the driving safety.
- 4 DO NOT use the DVR for a long time when the vehicle is not started, otherwise the battery may become flat and you will not be able to start the vehicle.
- 5 DO NOT insert/remove the memory card in charged state, otherwise the videos may be lost or even the memory card may be damaged.
- 6 When the memory card contains excessive data, resulting in insufficient capacity, the read/write rate may decrease. It is recommended to back up data and format the card via the head unit.
- 7 If there is excessive user data (not used by DVR) in the memory card, the DVR may not recognize the card. This DVR is compatible with high speed Micro SD card, and the recommended capacity is 64GB and above.

Overview

The vehicle is equipped with a digital video recorder (DVR), and the DVR camera is installed in the multi-function sensor cover of windscreen. The system records all images of the vehicle on the road, and can provide the image data in a quick, true and accurate manner to assist the traffic police in dealing with traffic accidents fairly, justly and reasonably, and protect the rights and interests of drivers from being infringed.

The information recorded by the camera is stored in a memory card, which needs to be inserted into the memory card jack next to the front console power socket to enable the DVR.

The system supports the real-time monitoring of the health state of the memory card. Click the Settings icon in the upper right corner of the DVR interface on the central screen to enter the Settings interface, where you can format the SD card, enable and disable the DVR.

Note: When using a memory card for the first time, please format the card through the head unit.

Loop Recording

When the vehicle is powered on, the system will automatically start high-definition loop recording, and overwrite the earliest videos after a period of time.

Live Preview

Touch [DVR] on the central screen to view the live preview.
Note: There may be a slight delay in preview and playback.

Emergency Recording

In the event of an emergency, a 12-second video will be captured into a separate video file and saved under the Emergency Video tag.

Intelligent Drive System*

Intelligent Drive Camera and Radar

Intelligent Drive Camera

The vehicle is equipped with the following cameras: surround-view camera and periscopic-view camera.

- The periscopic-view camera provides detection information for driver assistance system.
- The surround-view camera provides detection information for parking system.

The camera recognizes targets in visual form, providing recognition information for relevant functions after recognizing the targets around the vehicle.

Installation Position of Camera

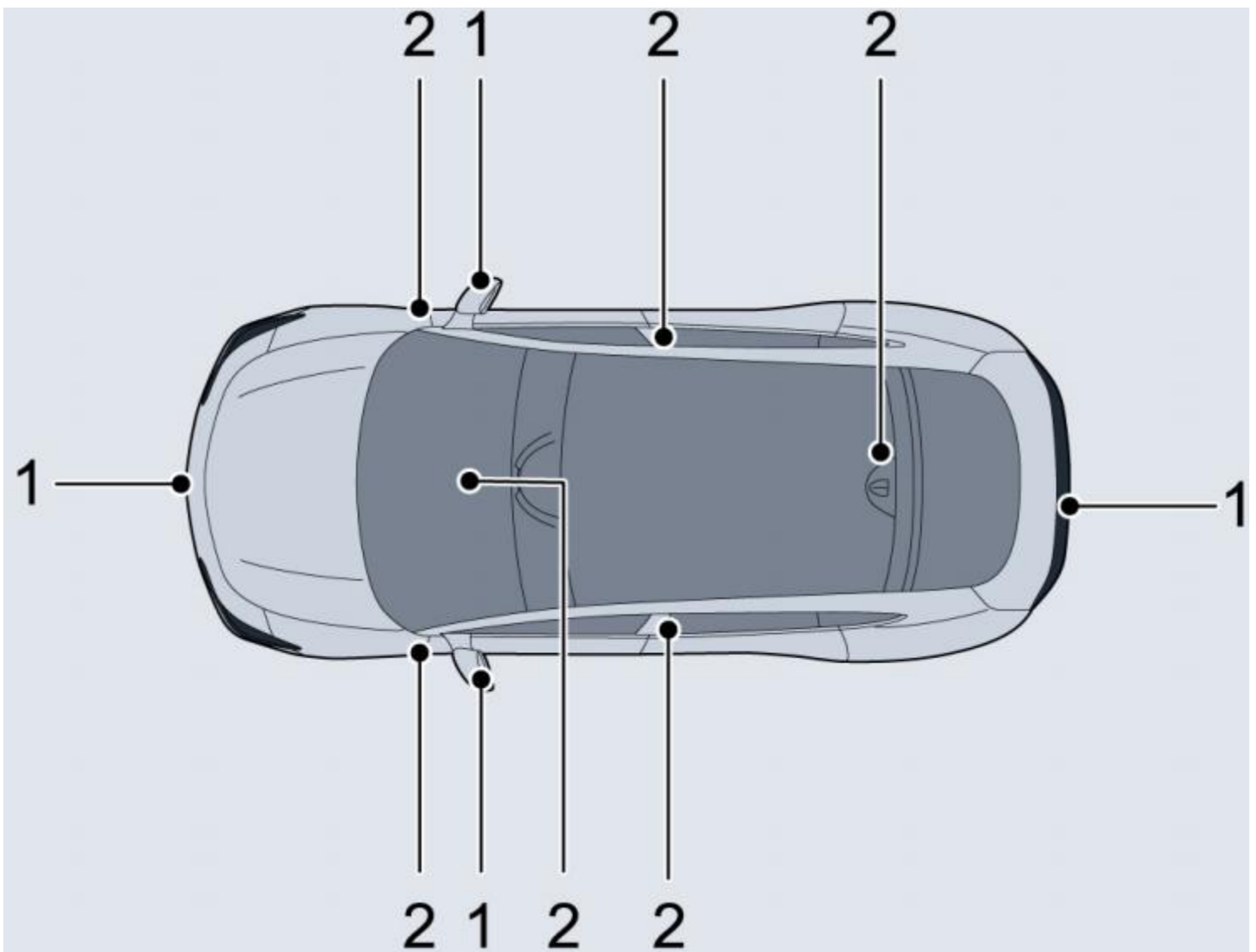

1. Surround-view camera
2. Periscopic-view camera

Intelligent Drive Radar

The vehicle is equipped with three types of radar: ultrasonic sensor radar, millimeter-wave radar and laser radar.

- The ultrasonic sensor radar provides detection information for parking system.
- The millimeter-wave radar and laser radar provide detection information for driver assistance system.

The radar is only used to detect targets around the vehicle, providing detection information for relevant functions.

Installation Position of Radar

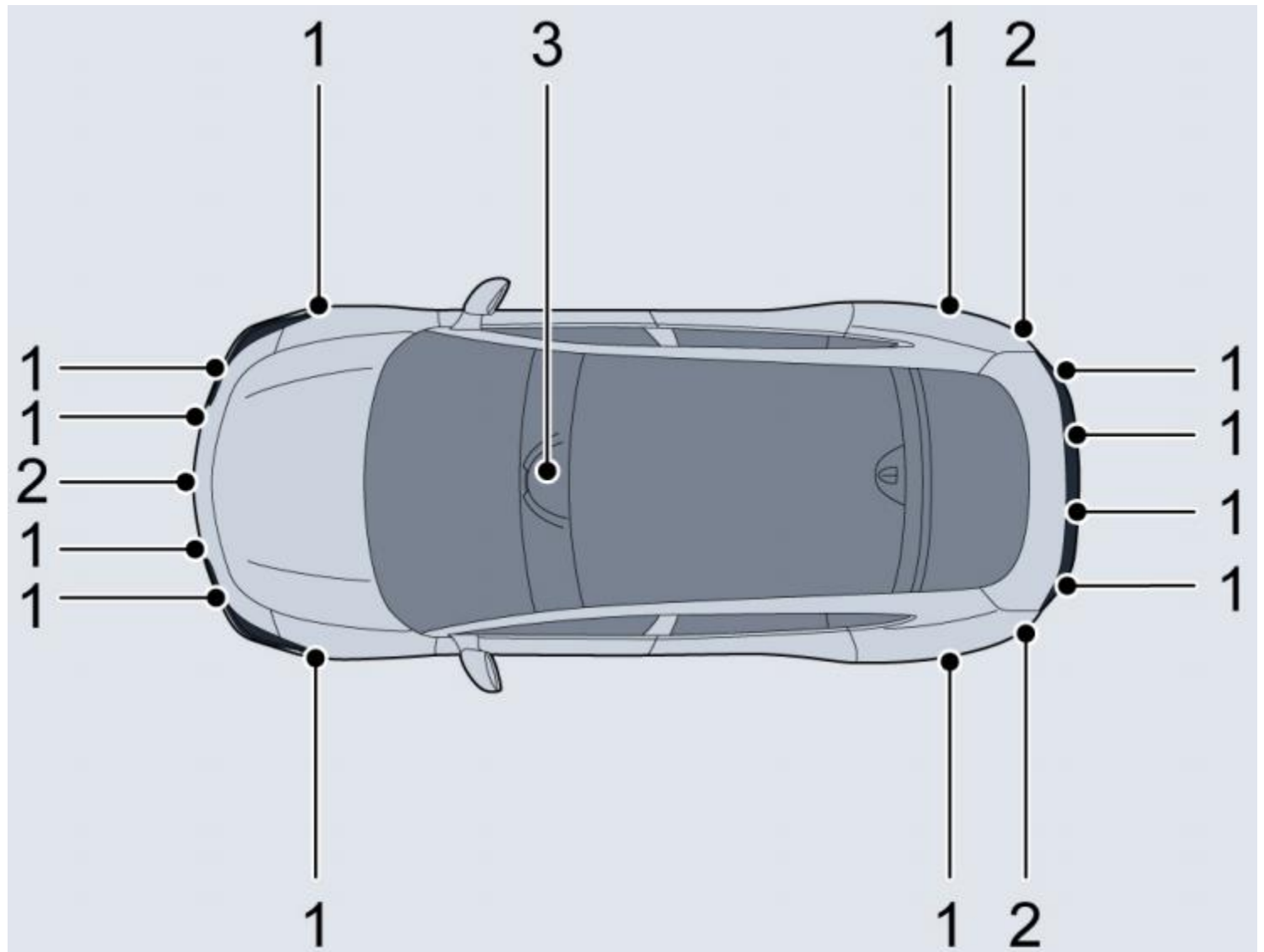

1. Ultrasonic radar
2. Millimeter-wave radar
3. Laser radar

Maintenance of Camera and Radar

Camera Maintenance

To ensure the normal operation of the camera, keep the camera clean and free of foreign objects such as snow, ice, water, and dust.

To ensure the normal operation of the camera, keep the windscreen in front of the camera clean and remove any objects blocking between the camera and the windscreen.

Wipe with soft cloth or wash with water (low pressure) the foreign objects on the camera surface. Do not flush the camera with high pressure water jet, or clean the camera with abrasive or sharp objects.

Radar Maintenance

To ensure the normal operation of the radar, keep the radar clean and free of foreign objects such as snow, ice, water, and dust.

Wipe with soft cloth or wash with water (low pressure) the foreign objects on the radar surface. Do not flush the radar with high pressure water jet, or clean the radar with abrasive or sharp objects.

Precautions of Intelligent Drive

The camera and radar cannot work normally in all driving situations or traffic, weather and road conditions. When the vehicle is in a complex or poor environment, you should drive cautiously and always be responsible for driving safety.

When the radar or camera is abnormal or damaged, please contact Authorised Repairer for replacement or repair.

The front and rear millimeter-wave radars are installed in the front and rear bumpers, respectively. Therefore, to avoid affecting the performance of the millimeter-wave radars, it is strictly prohibited to paint, retrofit and encircle the bumper.

Calibration of Visual Camera

The visual camera must be re-calibrated in the following situations:

- The visual camera is removed/installed;
- The assembly parts of the visual camera are removed/installed, such as the left and right rearview mirrors, front and rear bumpers, fender molding assembly, pillar B trim panel assembly, etc

Note: The visual camera shall be calibrated with the expertises and tools. Please contact the Authorised Repairer when calibration is required.

Calibration of Millimeter-wave Radar

The millimeter-wave radar must be re-calibrated in the following situations:

- The radar has a maladjustment failure, for example the position of the forward detection radar has changed;
- The radar or radar bracket is removed/installed;
- The front anti-collision beam is removed/installed;
- The four-wheel alignment parameters have changed.

Calibration of Laser Radar

The laser radar must be re-calibrated in the following situations:

- The radar has a maladjustment failure, for example the position has changed;
- The radar or radar bracket is removed/installed;

Note: After the radar suffers from strong vibration or slight impact, its installation position needs to be checked and re-calibrated if necessary.

Note: The radar shall be calibrated with the expertises and tools. Please contact the Authorised Repairer when calibration is required.

In the following situations, the detection performance of the visual camera will be affected:

- Driving in bad weather, such as heavy fog, heavy rain, heavy snow, dust, sand storm, etc. which cause visibility reduction;
- Affected by the light, such as: in the night and under poor auxiliary lighting, backlighting in the view, direct light from the oncoming vehicles, quick bright/dark jump (tunnel entrance/exit), driving on the strong reflective road surface (road surface with water or snows in rainy or snowy days), in the tunnels, buildings, etc.;
- The car drives on the places with insufficient light, such as: in the evening, at night, in the tunnel, building, underground parking lot, etc.;
- The camera is partially or fully blocked by the obstacles, such as foreign objects, oil stains, dust, mud, snow, rain, frost or splashed water, etc.;
- The windscreen in view of the front view camera is broken;
- The camera is not calibrated after removal/installation;
- The camera is not secured in place.

The radar detection performance will be affected in the following cases

- When the radar is covered by mud, snow, heavy rain or splashed water;
- When the front and surrounding areas of the radar are covered by such objects as labels or auxiliary lighting device;
- When the radar is subject to strong vibration or slight impact;
- Some targets may affect and weaken the detection of the radar, such as road fences and tunnel entrances;
- When the radar is affected by the environment, such as under electromagnetic field interference or due to the target itself;
- Radar signals that are strongly reflected (e.g., in multi-storey car parks, tunnels, water jets from sprinklers, etc.) may degrade the function of the radar sensor.

Note: The snow on the radar can be removed with a brush, while the ice on it is better to be removed with deicing spray.

Note: Never bump into the radar, for example, bumping into the radar when moving the car, which causes its displacement or damage.

Parking Assist System

Parking Assist System

The ultrasonic radars on the front and rear bumpers monitor the front and rear areas of the vehicle to search for obstacles. If an obstacle is detected, the system will calculate its distance to the vehicle and warn the driver to avoid the collision with warning tone. The radar warning tone can be turned on and off through the 360 AVM Settings interface.

When the vehicle is running at a low speed, the parking assist system automatically starts to work. When the rear obstacle is detected, the driver screen will display the distance of the obstacle to remind the driver. The system is turned off when the speed is above 15km/h. Note: After R gear is selected, if the ultrasonic radar fault message pops up on the driver screen, it indicates a system failure, please contact the Authorised Repairer for service.

With the parking assist system function enabled, if an obstacle is detected, the system will give warning sounds in different frequencies. (there might be blind zones)

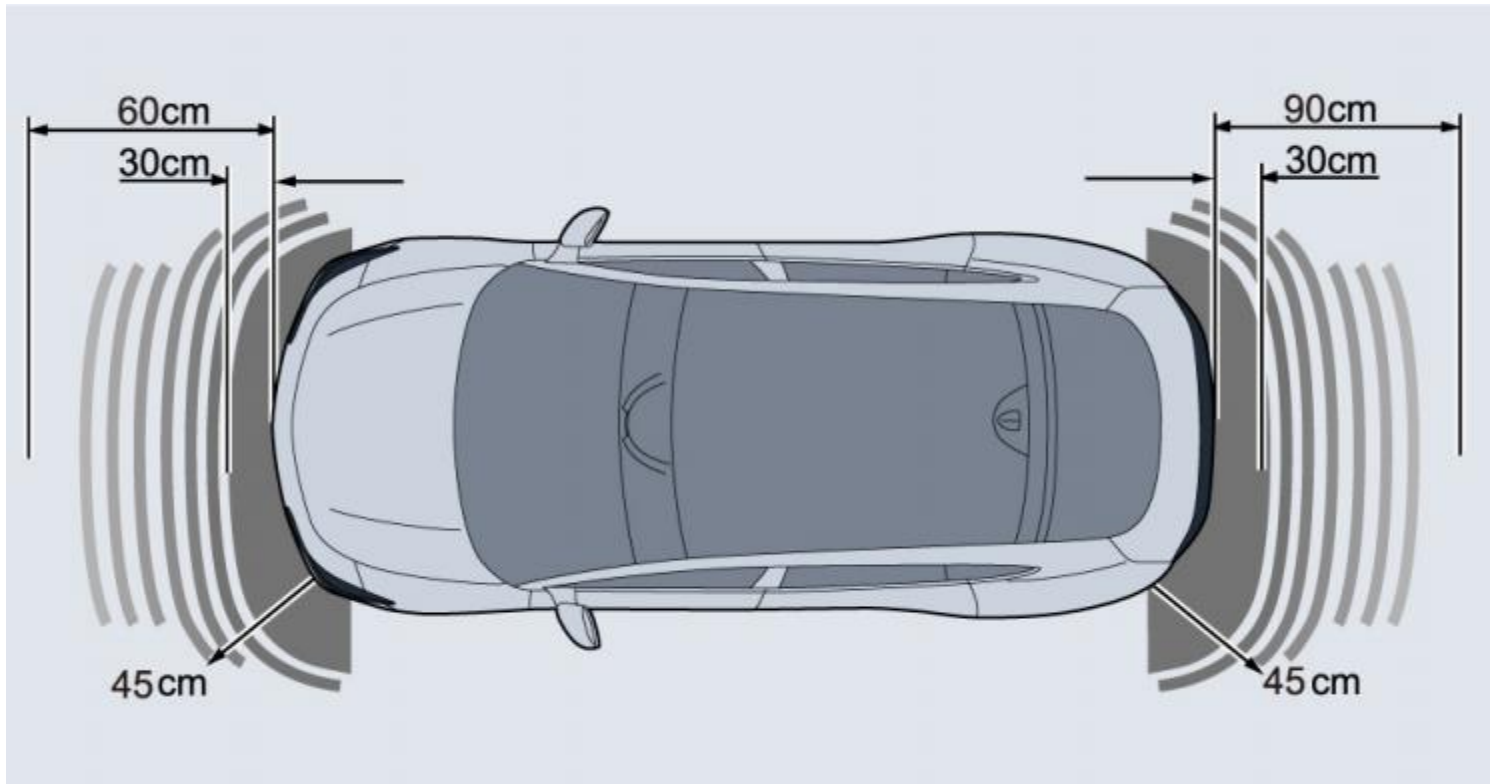

- If an obstacle is detected within 90 cm in the rear or within 45 cm at the corner, the warning sound commences. As the car moves closer to the obstacle, the warning sounds are transmitted more rapidly.
- If an obstacle is detected within 60 cm in the front or within 45 cm at the corner, the warning sound commences. As the car moves closer to the obstacle, the warning sounds are transmitted more rapidly.
- Once the obstacle is within 30 cm of the front and rear bumpers, the warning sounds will merge into a continuous sound. If both the vehicle and the obstacle are stationary, the warning sound will stop 3s later.

Important Instructions for Using Parking Assist System

Warning: The purpose of the parking assist system is only to assist the driver during parking! The ultrasonic radar may not be able to detect certain types of obstacles, such as thin posts, small objects close to the ground, objects above the tailgate and some objects with low reflectivity.

Warning: Due to the different material, shape and reflectivity of obstacles, the ultrasonic radar may provide inaccurate measurement distance, missing alarms and false alarms, therefore, it only serves as a driver assistance function and can not be completely relied on when used.

Warning: When the speed is above 5km/h, the output distance of ultrasonic radar may be delayed, please drive safely.

Image Assist

360 Around View Monitor (AVM)

With the 360 around view monitor (AVM) system working, the driver interface will show 360 around view of the vehicle to facilitate the observation of surrounding environment and make the driving environment much safer. You can touch buttons on the display to view images from different perspectives around the vehicle.



When the speed is less than 20km/h and not in R gear, you can enter the 360 AVM system by the following operations:

- Select R gear;
- Turn on the 360 soft switch on APP list;
- Open the set steering wheel to customize 360 shortcuts;
- Start the vehicle in the Settings options to enable the AVM function, with the vehicle powered on and shifted to "D" gear for the first time.

Note: When the shift lever is placed in D position, in no case can 360 AVM be enabled as long as the vehicle speed exceeds or equals to 20 km/h.

In 360 AVM Display interface, perform personalized setting for the relevant system functions.

The transparent chassis of 360 AVM is a technology that makes the image collected by the camera in advance show transparent effect after technical processing, and transmits it to the entertainment display, which is convenient for the driver to see the road conditions in the car.

Note: The transparent chassis of 360 AVM cannot recognize the possible changes beneath the vehicle when the vehicle is stationary.

Please drive with caution when using this function, and pay attention to actual environment to avoid damage to the vehicle.

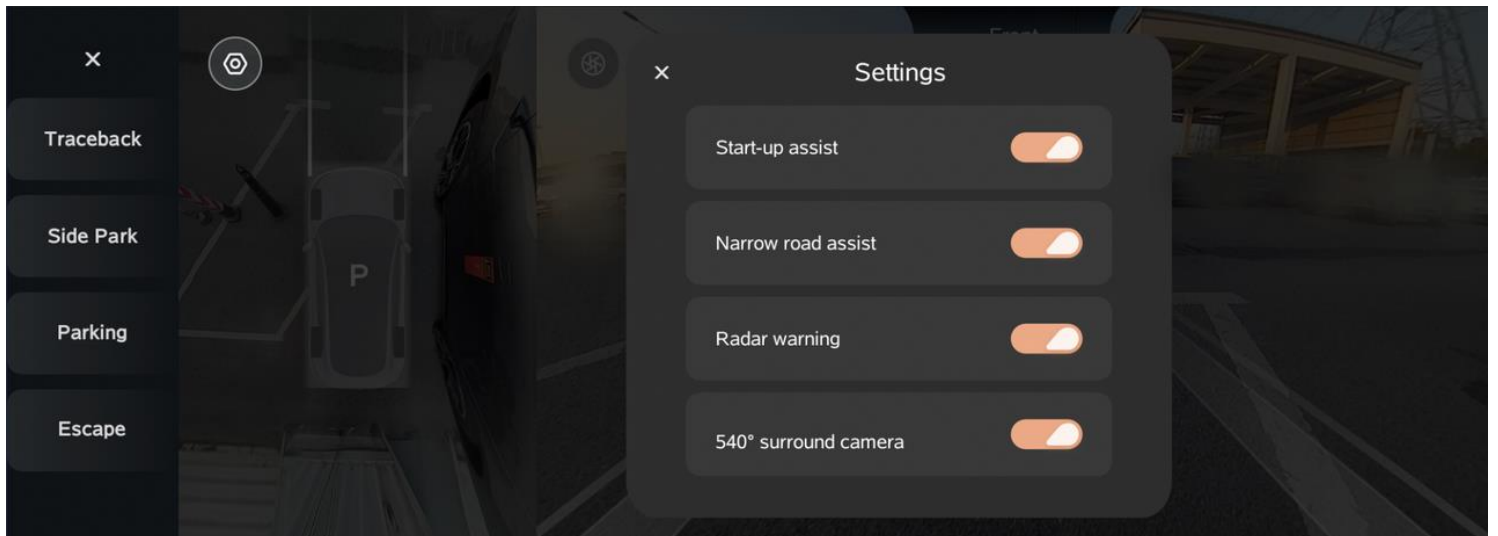

Blind Spot Detection

Rearview Blind Spot Detection

The rearview blind spot detection function transfers the images taken by the camera directly behind the vehicle to the driver screen to provide a wider and clearer field of vision than interior rearview mirrors. This function is enabled and disabled by controlling the roller on the right of the steering wheel upward and downward, respectively. The display length of rearview blind spot image can be set in Central Screen - Vehicle Settings - Intelligent Drive Page.

After the intelligent rearview blind spot detection switch is turned on, the rearview blind spot detection will be enabled in the following scenarios:

- Automatic emergency braking is triggered;
- The backward expression function of Digital Light Processing is enabled (giving a like, making a finger heart, etc.).

Side Blind Spot Detection

Turn on the side blind spot detection function switch, and turn on the turn signal lamp when the speed is lower than 150km/h, and the driver screen will display the real-time image of the blind spot behind the steering side.

The side blind spot image cannot be displayed in the following scenarios:

- Around View Monitor is enabled;
- In Super Energy Saving Mode;
- In half screen;
- The intelligent Pillar A blind spot detection switch is turned on and the speed is lower than 20km/h (the rear left blind spot image cannot be displayed);
- The vehicle just starts

Intelligent Pillar A Blind Spot Detection

Turn on the intelligent Pillar A blind spot detection function switch, and turn on the left turn signal lamp when the speed is lower than 20km/h, and the left driver screen will display the real-time image of the front left blind spot.

The Pillar A blind spot image cannot be displayed in the following scenarios:

- Around View Monitor is enabled;
- In Super Energy Saving Mode;
- In half screen;
- The vehicle just starts.

Important Instructions for Using Image Assist

Warning: The image assist system only plays a role of assistance! The camera has limited field of view and limited display of the image assist, and cannot detect obstructions outside the field of view.

Warning: Please still pay attention to the current actual road conditions for your driving safety.

S-APA with Fusion

Shiftless Automatic Parking Assist System with Fusion (S-APA with Fusion)

The S-APA with Fusion can assist the driver in automatically parking the car into a parking slot recognized by the system that has lines on the ground or is unoccupied beside any car.

The system supports intelligent parking-in function to perpendicular or horizontal parking slot. If the parking slot has a clear marking line and enjoys good lighting conditions, the system can also complete the detection of the parking slot without using reference objects on both sides of the parking slot.

When a system failure is detected, the system function is unavailable, and the vehicle will give a corresponding prompt.

System Operation

During parking, please follow the prompts on the central screen.

Make sure the following conditions are met before parking:

- No system failure is detected;
- Four doors and two covers are closed.

Note: After clicking “Start Parking”, please do not release the brake pedal before the system prompts “Please Release Brake”.

Parking-in Operation

1. When the speed is less than 20 km/h, enable the automatic parking assist function through the "One Touch Parking" in the main interface of the central screen, and the system begins to search for parking slot.
2. After a parking slot is found, you can depress the brake pedal to stop the car safely. You may select the parking slot as needed on the central screen, and start automatic parking after confirmation.
3. The system prompts successful parking.

Note: After the system finds a parking slot, if the vehicle continues to travel out of range, the system will search for the parking slot again.

Interruption or Exit

- In the process of searching for parking slots, when the speed is above 25 km/h, the system will skip to the APA main interface.
- During the parking process, if you intervene with the steering wheel, the system will exit.
- During the parking process, if you intervene with the gear, the system will exit.
- During the parking process, if you open the door, the system interrupts; after the door is closed, you may operate on the central screen to resume parking.
- During the parking process, if you intervene with the braking, the system interrupts; after the brake is released, you may operate on the central screen to resume parking.
- During the parking process, if there is any other abnormalities, the system will exit.

Note: The system prompt messages shall be subject to real vehicle.

Silent Search

When you drive into any place such as special parking lot, road parking lot, non-parking lot without marking lines (temporary roadside parking area, temporary parking area in open space), and when the speed is lower than 15km/h in D-gear mode, the silent search function can automatically start to silently look for nearby parking spaces without any operation from you. A parking space icon will be displayed on the instrument screen when an available parking space is found.

Tip: The parking space icon is displayed only when the parking space complies with the S-APA with Fusion [APA] functional dimensions and space requirements, and the vehicle position and surroundings also meet the APA requirements.



Tip: In R-gear mode, when the reverse speed is lower than 8km/h, the silent search function may also automatically look for available parking spaces around (In R-gear mode, the silent search function only supports perpendicular parking space with clear marking lines and spacial perpendicular parking space without clear marking lines).

You may use the silent search function to complete parking by the following steps:

1. When a parking space icon is displayed on the instrument screen, if you want to park into one of the parking spaces, you should brake and stop the vehicle, observe if the selected parking space and its surroundings are suitable and safe for parking, and determine the target space is suitable for parking.

2. The APA can be enabled quickly in the following methods

Method 1: Engage in R gear if currently not in this gear to quickly enable APA, and the APA interface will appear in the central screen;

Tip: Method 1 is available only when the "Quick One Touch Parking" setting button is set to be On, which is in "Settings" on APA interface.

Method 2: Click the "One Touch Parking" button on the HOME interface of the central screen to quickly enable and go to the APA interface;

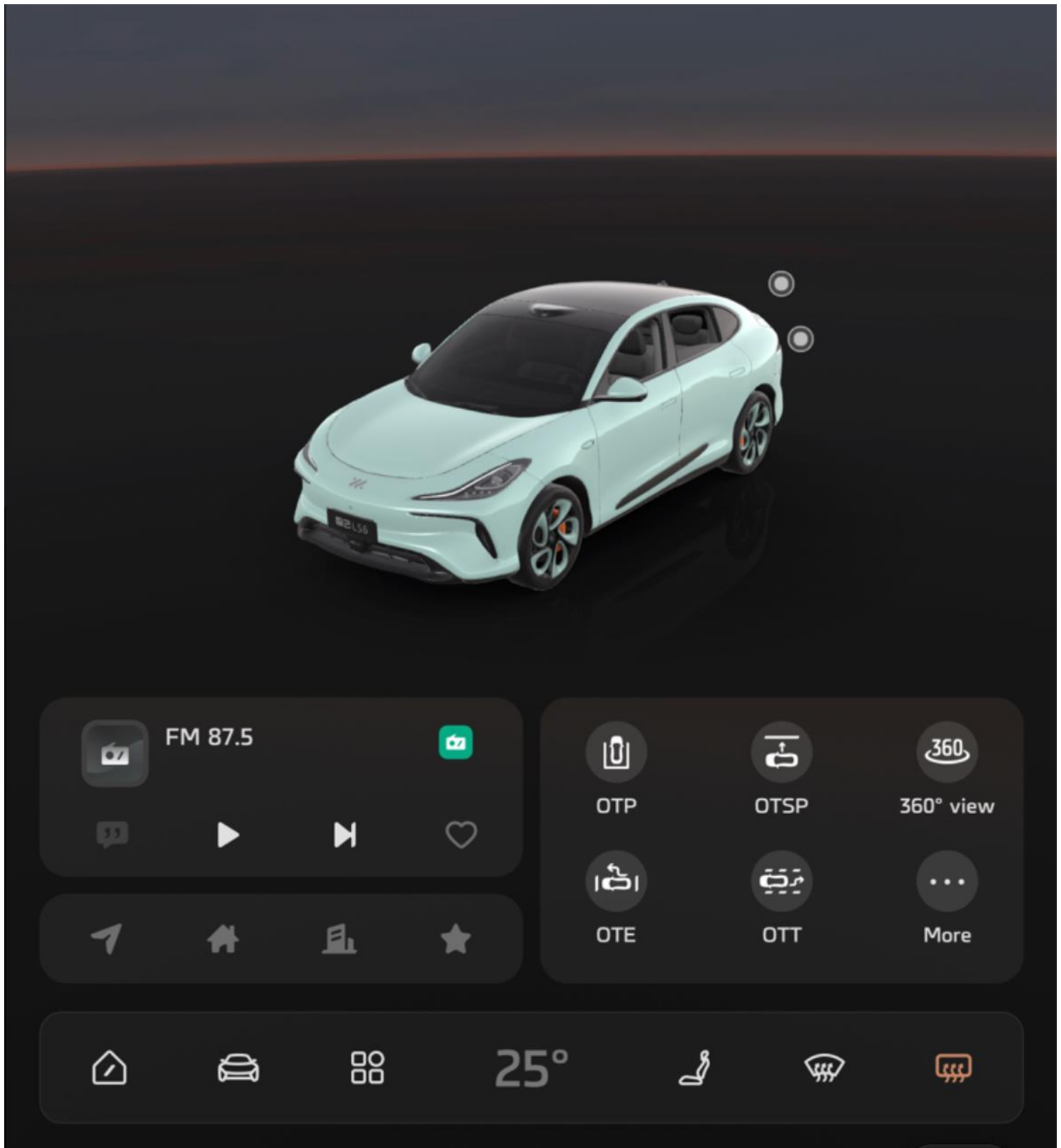

Method 3: Click the “OTP” button in One Touch iAD on the APP menu interface of the central screen to quickly enable and go to the APA interface;



Method 4: Click the “Parking” button on the 360 interface to quickly enable and go to the APA interface.



3. After selecting and determining the target parking space, click “Start Parking”

After entering APA interface, select and determine the target parking space, and click “Start Parking” to use the APA to assist in parking the vehicle into the target parking space.

For detailed use guidance, warnings and important notes, please refer to the Instructions for Use of [S-APA with Fusion Function].

Function Limitation and Errors:

1. Dark or low-light environments will significantly reduce the sensor's perception capability, which can affect the smooth operation of the function.
2. Rainy, foggy, snowy or extremely cold or hot and other adverse/severe weather environments will significantly interfere sensor's perception capability, which can affect the proper operation of the sensor.
3. When other intelligent driver assistance functions are working, the silent search function cannot be enabled.
4. When the vehicle speed is higher than 15km/h, the silent search function will be automatically exited.
5. The silent search function does not work when driving on ramps.
6. The opening of the door or the hood or trunk causes the silent search function to exit.

The warnings, limitations, or error examples above do not cover all of the conditions that may affect the proper operation of the silent search function, therefore the driver must remain attentive when using the function, always prepare to take over, and take full responsibility for the safety of vehicle and surroundings at all times.

Important Instructions for Using S-APA with Fusion

Warning: You should understand that this system is only designed to assist the driver in parking, and the driver is still the main operator, and should comply with national and local traffic safety regulations, and be responsible for the safety of the entire parking process. You should judge the use of the system based on the overall environment (such as weather, geographical environment, etc.), and assume the corresponding responsibility for your judgment.

- You should ensure that the system is used in good light, suitable weather conditions, flat road with no significant slope, compliance with the requirements for safe driving and sufficient electricity. When the system is in use, the exterior rearview mirror should be kept unfolded, and the front, rear, left and right cameras are in normal working state.
- Keep the rearview mirror unfolded when using the function to ensure that the left/right camera correctly identifies the marking line.
- If the surface of the camera is stained or blocked, the perception capability will be affected, resulting in failure to identify parking slots. Please clean the camera in time.
- If no parking slot can be found, please drive as close to the parking slots as possible to find a parking slot faster.
- You must always check and confirm that the parking slots found by the system is safe and suitable for parking, and never rely on the system to find a suitable parking slot. The system may misidentify a parking slot on the road, at the entrance of the passageway, in bushes, etc., in which case you have to determine the rationality of the parking slot. The system cannot determine whether the parking slot found is legal or not, thus you have to confirm that the parking slot is legal before starting the parking process.
- The system only displays the parking slots that can be parked according to its capability. The availability of parking will vary with the environment, not just with the size of the parking slot. If an obstacle suddenly appears around the vehicle during parking, please take over in advance, because the system may not be able to brake in time.
- Due to the surrounding environment, the system may complete the parking in advance, and you shall adjust the vehicle position as appropriate.
- When running on a ramp, the APA may not work as expected and you need to use it with caution.
- The system performance depends on the ability of ultrasonic sensor and surround view cameras to detect and recognize the environment. The sensor is limited in recognition ability and range, and it cannot recognize obstacles that are suspended, and small in both volume and width. When there are similar objects in the parking environment, please watch out and ensure that the environment is suitable and safe, and be ready to intervene at any time to take over the vehicle to avoid a collision.
- Always alert of collision risks, and watch out surrounding trees, iron poles, fire hydrants, fire hydrant pipes, stone piers, low steps or stools, low curbs, protruding objects on surrounding vehicles or open doors, roadside fences, flower pots & plants, flowerbed bushes, overhangs, overhanging warning lines and other unrecognized obstacles to avoid collision.
- If the luggage racks or bicycles and other objects are placed on the roof, please pay attention to not rubbing space objects (such as A/C ventilation pipes, etc.) during use.
- During automatic parking, the driver can judge the distance information of obstacles through the parking radar assist alarm function to avoid collision risks.
- Although the system has the ability to automatically pause to avoid obstacles, due to the limitations of the sensor, you should maintain an intense concentration to observe obstacles, pedestrians, vehicles and other potential threats around the vehicle, and be ready to brake to avoid vehicles, pedestrians and objects. Assumes no liabilities for any accidents, bumps, scratches, etc. due to sudden changes in the surrounding environment or the driver's non-compliant operations.
- The APA is recommended for scenarios with standard lined parking slots, and not for mechanical garages, irregular diagonal lines, or the places that cannot be recognized due to perception limitations.
- The parking slots on narrow streets, or narrow parking slots are not always available as the necessary operating space may be insufficient.
- The parking may fail in too narrow parking slot (about 2.75m and below) or due to space limitations.
- Please try to avoid parking in micro-parking slots, which, due to insufficient parking space, may cause collision risks when the wheels cross the chocks.

One Touch Escape (OTE)

One Touch Escape (OTE)

When you park in vehicle and engage in P gear using the S-APA with Fusion, you can use the intelligent parking-out function as long as you have not moved the vehicle. The parking-out function can automatically control the steering and speed, help you drive the vehicle out of the parking space, and what you have to do is to take over the vehicle and drive it forward.

Note: The current version only supports the parking out from the horizontal parking lot, and the intelligent parking-out function for perpendicular parking lot will be iterated and launched later.

Tip:

1. When there is no obstacle near the front of your car, you can easily park out, in this case, the intelligent parking-out function will be unavailable for use;
2. The available space length without obstacles before and after the vehicle must be not less than 1.5 meters to ensure smooth parking out.

The intelligent parking-out function is completed by the following steps:

1. The intelligent parking-out function can be enabled in the following methods:

Method 1: Click the "Escape" button on the 360 interface to enable the intelligent parking-out function, and enter the intelligent parking-out function interface;

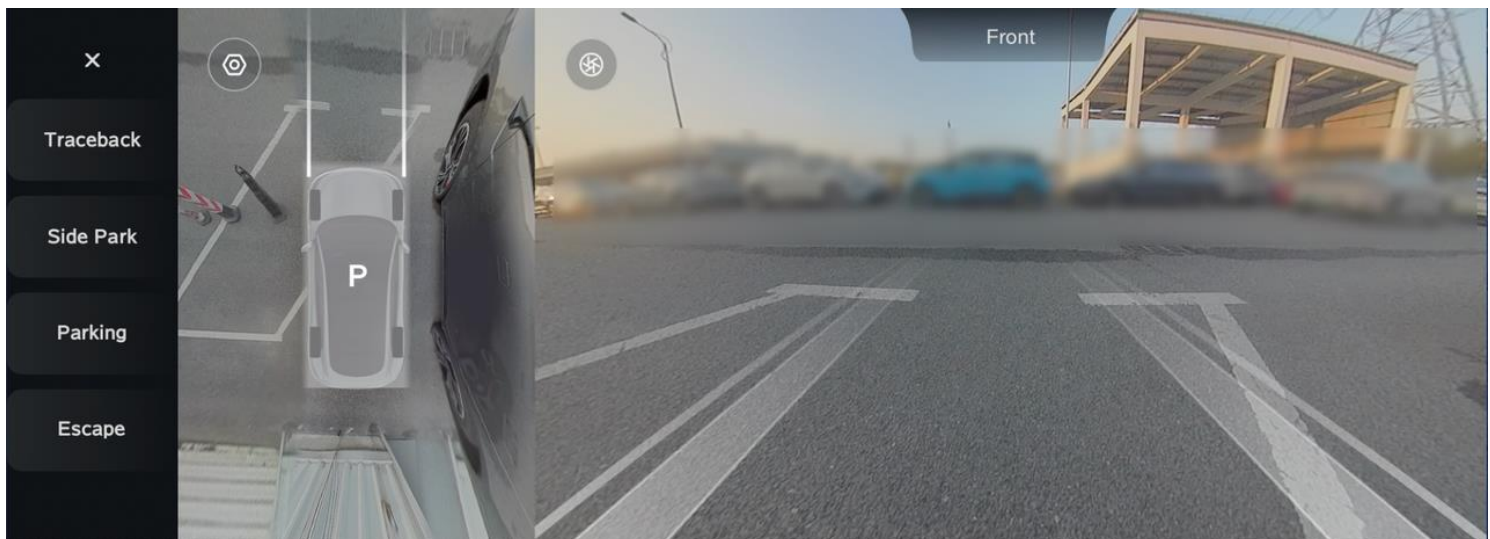

Method 2: Click the "OTE" button on the HOME interface of the central screen to enable the intelligent parking-out function, and enter the intelligent parking-out function interface;

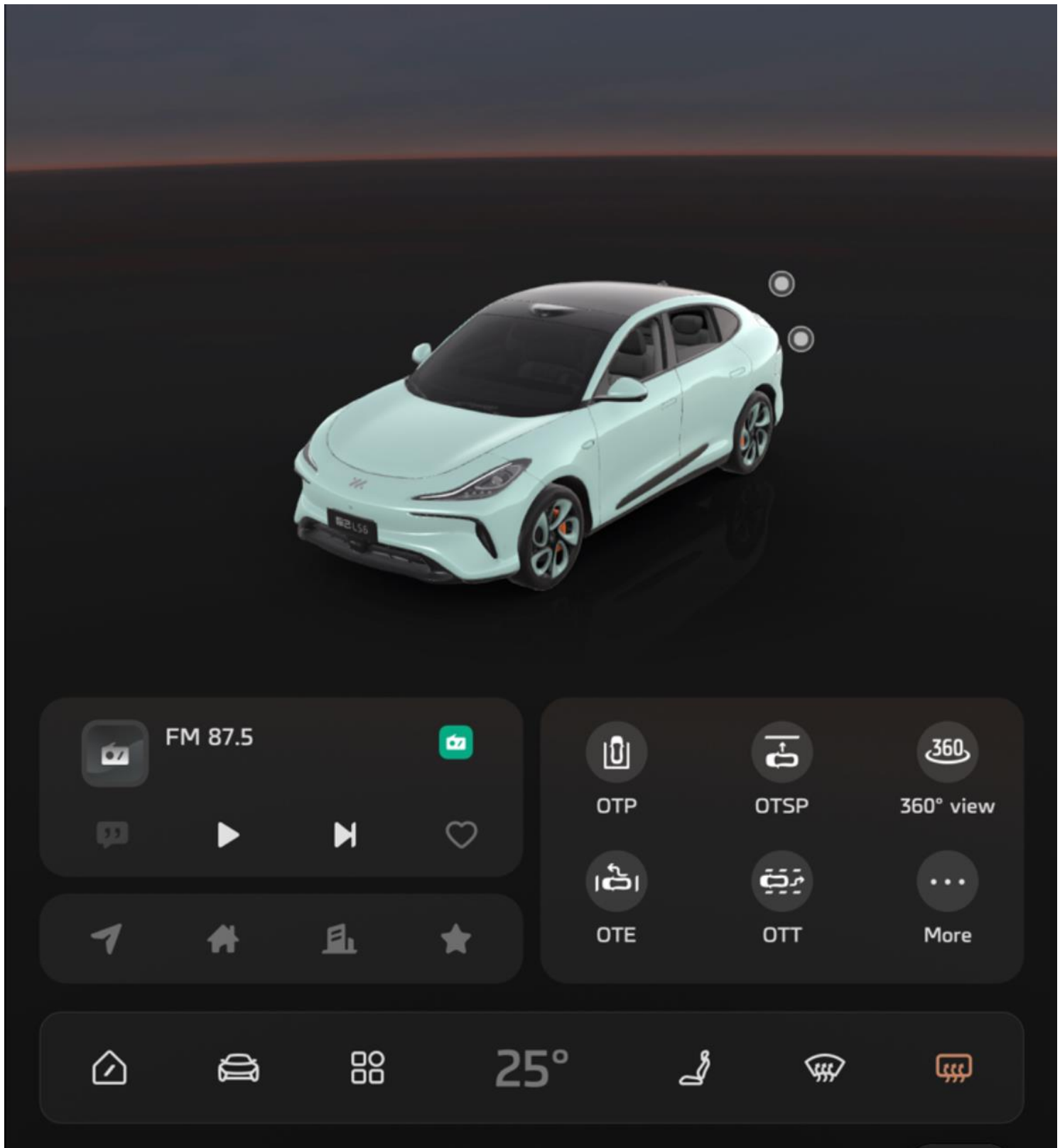

Method 3: Click the “Escape” button in One Touch I AD on the APP menu interface of the central screen to enable the intelligent parking-out function, and enter the intelligent parking-out function interface;



2. Select and confirm the parking-out direction

This function will automatically detect and display the available parking-out directions to the front left and front right; click the direction button, and you can switch to select the desired direction. When this function determines that a direction is not suitable for parking out due to obstacles, this direction will not be available for selection.

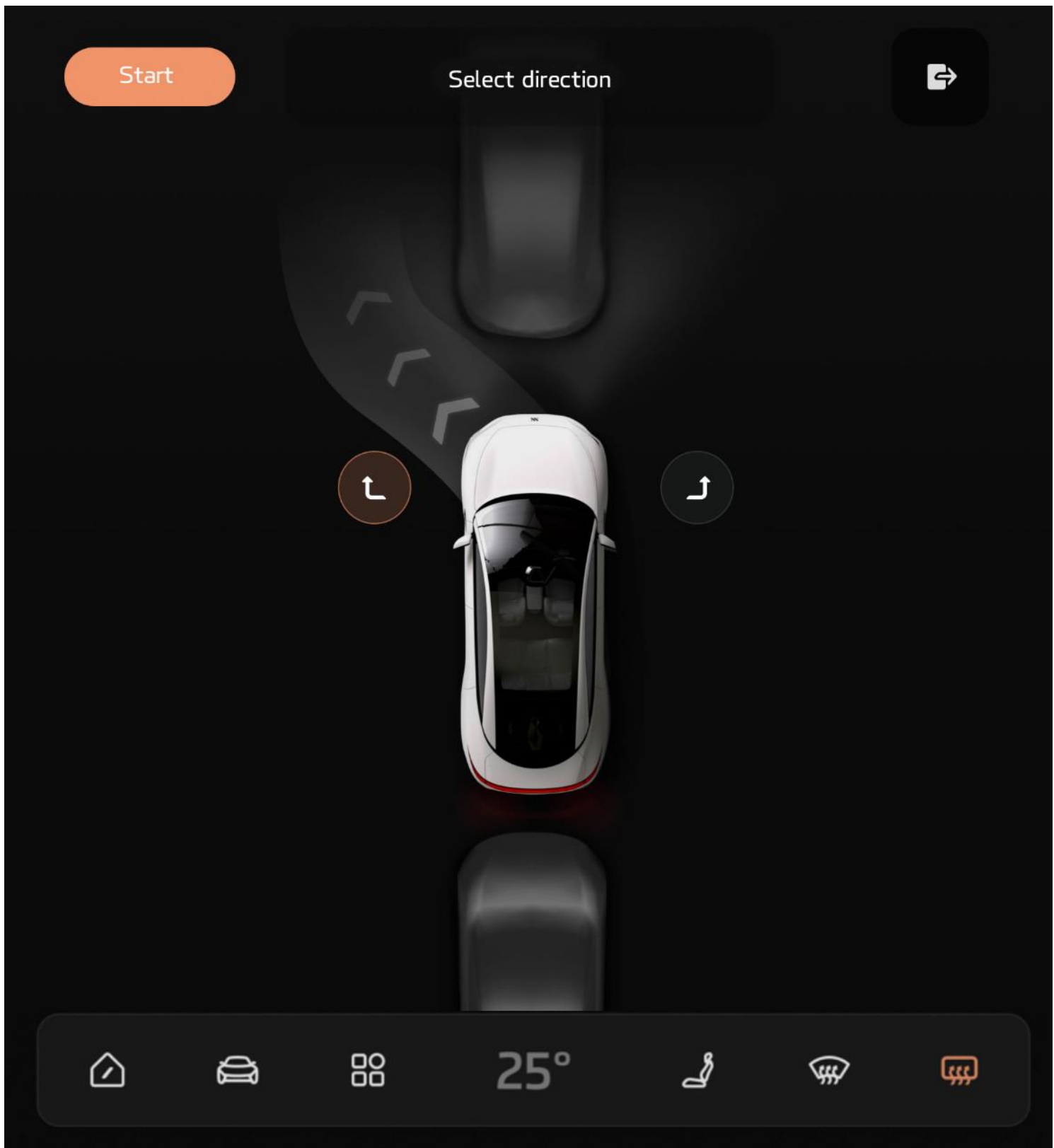

In general, this function will default to recommend and select the direction that you used the APA for parking in the last time; however, when the function determines that this direction is not suitable for parking out, it will not recommend it for you.

Note: Sometimes this function cannot make direction recommendations because the system may fail to recognize or remember a clear parking-in direction.

When you select a parking-out direction, the function will display the path range that the parking-out process will go through. Please make sure that there are no objects in this range such as obstacles that cause scratches or collisions, and follow the operation prompts on the function interface to start the parking-out operation.

3. Operate the intelligent parking-out function

During intelligent parking-out operation, the interface will display the change of the relative position relationship between the current vehicle and the parking space in real time. This function will automatically control the steering and speed of the vehicle, but you still need to keep an eye on the surroundings to ensure the safe parking-out process.

4. Complete parking out

After this function is completed, it will automatically engage your vehicle in P gear, and prompt: Parking Out Completed.

Pause and exit of the function:

1. The intelligent parking-out process will be paused in the following cases:

- ① Click [Pause] button in the function interface;
- ② Depress the brake or open the door;
- ③ The time from brake to stop exceeds a certain period of time due to obstacles.

After the function is paused for a certain period of time, you can click the [Continue] button in the function interface to continue the parking-out operation.

2. The parking-out process will be exited in the following cases:

- ① The driver intervenes with the driving;
 - Turn the steering wheel
 - Move the shift lever
- *The function has no response when the throttle is depressed
- ② Click [Exit] button in the function interface;
- ③ The function is paused for more than 1 minute due to obstacles;
- ④ Abnormalities such as system failure.

Instructions for Using One Touch Escape (OTE)

Warning: You should understand that this system is only designed to assist the driver in parking out, and the driver is still the main operator, and should comply with national and local traffic safety regulations, and be responsible for the safety of the entire parking-out process. You should judge the use of the system based on the overall environment (such as weather, geographical environment, etc.), and assume the corresponding responsibility for your judgment.

- The system performance depends on the ability of ultrasonic sensor and surround view cameras to detect and recognize the environment. The user is required to monitor the vehicle safety in real time, and take over the vehicle if necessary to ensure the safety of the vehicle and surroundings.
- Currently, the sensor cannot identify hanging, small, and narrow obstacles. If there are such obstacles in the environment, please watch out and ensure that the environment is suitable and safe, and be ready to intervene at any time to take over the vehicle to avoid a collision.
- Keep the rearview mirror unfolded when using the function to ensure that the left/right camera operates properly.
- If the surface of the camera is stained or blocked, the perception capability will be affected, resulting in failure to identify the surroundings. Please clean the camera in time.
- During the operation of the function, due to the blind spot of the perception system, it will not be able to timely detect and identify the vehicles passing in front and at the back or the pedestrians approaching quickly, resulting in failure to stop and avoid in time.

The warnings and important notes of S-APA with Fusion are also applicable to the intelligent parking-out function, refer to “Warnings and Important Notes of S-APA with Fusion”.

Function Limitation and Errors:

The parking-out function may not operate properly in the following scenarios

1. Dark or low environments will significantly reduce the sensor's perception capability, which can affect the smooth operation of the function.
2. Rainy, foggy, snowy or extremely cold or hot and other adverse weather environments will significantly interfere sensor's perception capability, which can affect the smooth operation of the function.
3. When other intelligent driver assistance functions are working, the intelligent parking-out function cannot be enabled.
4. Currently, the parking-out function is supported only from parallel parking space, rather than from the vertical, diagonal or irregular parking space.
5. Currently, the parking-out function is available only after you use the S-APA with Fusion function for parking in; for manual parking-in scenario, the parking-out function will not be available.
6. The function will not operate when the spatial length between the front and back of the vehicle is less than 1.5 meters.
7. When the system identifies that there is no obstacle within 4 meters in front of the vehicle, it will determine that you can easily park out, in this case, the intelligent parking-out function will not be available for use.
8. If the vehicle has moved since last parking in and engagement in P gear, then the function cannot be enabled.
9. When the system identifies that there are obstacles on both sides of the vehicle within a certain range, resulting in insufficient space required for parking out, the function cannot work.
10. The intelligent parking-out function does not work when driving on ramps.
11. The sensor cannot identify the road with height difference, so do not use the function on the road with cliffs and steps to avoid accidents.
12. When the steering wheel angle is too large, it will cause failure of the function to work, so please try to correct the steering wheel before enabling the function.

One Touch Side Parking (OTSP)

One Touch Side Parking (OTSP)

When the user stops the vehicle and the vehicle is in stationary state, the user can enable the one touch side parking function to make the vehicle complete a lateral translation to the left/right side one or more times at a fixed step of 15cm, until the vehicle is pulled over.

Tip:

The current one touch side parking function is designed for the scenes with reference objects such as curbs and walls. After the lateral translation and approaching of the vehicle to the left or right side at a fixed step of 15cm/time, the vehicle will be aligned and parallel to the reference object (If the angle between the rear and the reference object is about 18.3° or the angle between the front and the reference object is about 6.1° , the one touch side parking function can work normally); if there is no appropriate reference object, the lateral translation of the vehicle to the left or right side at a fixed step of 15cm/ time is carried out (the position of the body after the approaching is consistent with that before the approaching).

Before using the one touch side parking function, the user shall keep the body as parallel to the surrounding reference object (such as curbs and walls) as possible.

It is recommended to use the one touch side parking function when the distance is greater than 20cm from the curb and greater than 40cm from the wall, and the total distance (from the front of the vehicle to the vehicle ahead + from the rear of the vehicle to the vehicle behind) is greater than 1.5m.

1. Enable the function

Method 1: Click the “Side Parking” button on the 360 interface to enable the one touch side parking function, and enter the one touch side parking function interface.

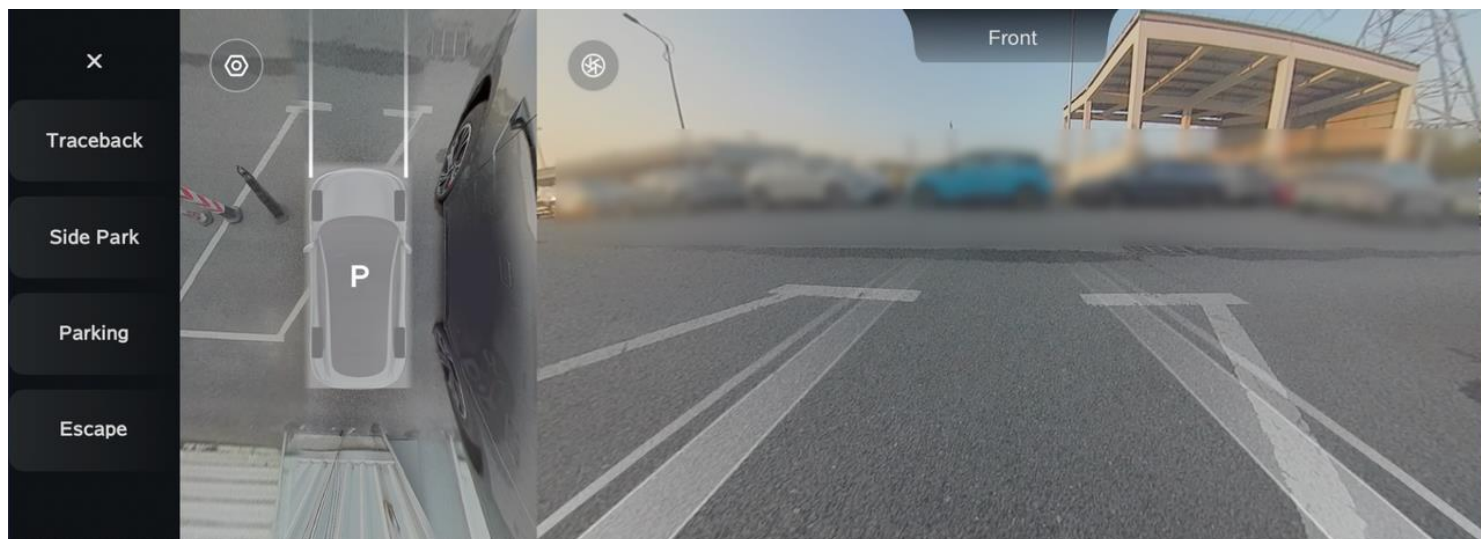

Method 2: Click the “OTSP” button on the HOME interface of the central screen to enable the one touch side parking, and enter the one touch side parking interface.

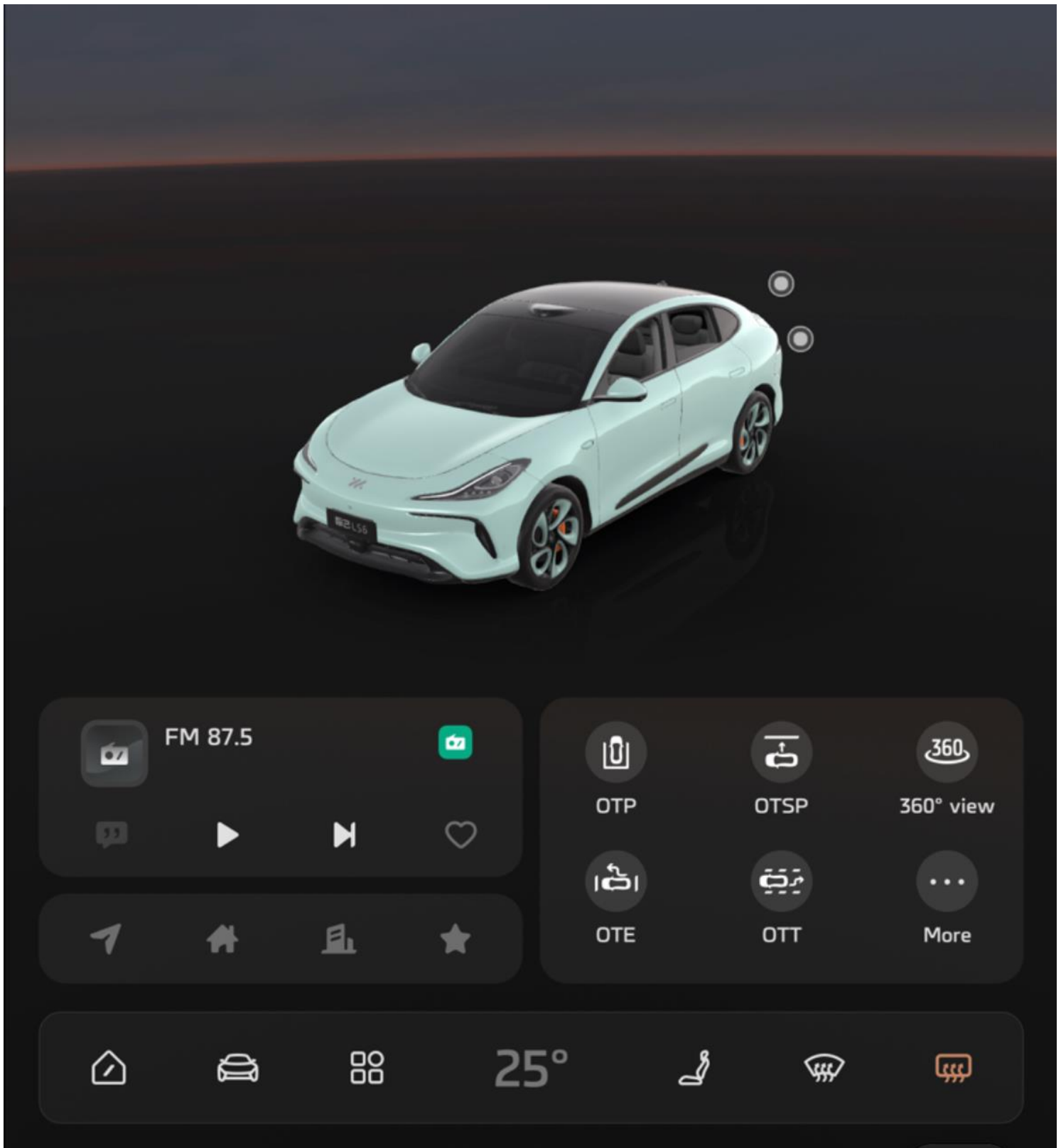

Method 3: Click the “Side Parking” button in One Touch iAD on the APP menu interface of the central screen to enable the one touch side parking, and enter the one touch side parking interface.



2. Activate the function

- ①After entering the “One Touch Side Parking” interface, the vehicle shall be in P gear or Auto Hold mode;
- ②Select the direction for one touch side parking;
- ③Read and confirm the Instructions for Use;
- ④Click “Start” button to carry out one touch side parking;
- ⑤During operation, the function will automatically control the vehicle to steer, move forward and backward, but the user is still required to always watch out the surroundings of the vehicle.

3. Complete the function

After function is completed, it will automatically engage your vehicle in P gear and prompt: One Touch Side Parking Completed.

4. Use the function again

After the one touch side parking function is completed, you can use the function again by clicking the "Side Parking" button on the large screen according to actual needs.

Pause and exit of the function:

1. The one touch side parking function will be paused in the following cases:

- ① Click [Pause] button in the large screen function interface;
- ② Depress the brake;
- ③ Open any door/hood/trunk;
- ④ Vehicle is braked to stop due to obstacles (within 60s after the pause of the function, the user can click [Continue] button in the large screen function interface to resume the one touch side parking function).

2. The one touch side parking function will be exited in the following cases:

- ① The driver's intervention
 - Turn the steering wheel
 - Move the shift lever
 - Power off the vehicle
- *The function has no response when the throttle is depressed;
- ② Click [Exit] button in large screen function interface (in Pause page);
- ③ The function pause is out of time (more than 60s) due to obstacles not removed;
- ④ Abnormalities such as system failure.

Instructions for Using One Touch Side Parking

Warning:

Currently, the sensor is unable to identify hanging or small obstacles. Therefore, do not use the function on cliffs and the side of roads with steps. If the function is used in the environment above, note to watch out and ensure that the environment is suitable and safe. In addition, always pay attention to the actual distance between the vehicle and the reference object, and be ready to take over the vehicle if necessary to avoid collisions and accidents.

Keep the exterior rearview mirror unfolded when using the function to ensure that the left/right surround view camera operates properly.

It is not recommended to use one touch side parking function when the vehicle runs on road with potholes, bumps, ditches, and slope angles of more than 5°, in dark or poor lighting environment, and in adverse weather environment such as rainy, foggy or snowy days.

If the surface of the surround view camera is stained or blocked, it will affect the sensor perception capability. Please check the surface status of the camera and clean it in time before using the function.

The warnings, limitations, or error examples above do not cover all of the conditions that may affect the proper operation of the one touch side parking function, therefore the user must remain attentive when using the function.

One Touch Traceback (OTT)

One Touch Traceback (OTT)

One touch traceback function (hereinafter referred to as: Tracking function) will automatically and silently remember the longest effective memory path of 50m when the speed is 0~25km/h without any operation from you. When you drive into difficult road conditions, such as meeting on narrow road, dead end street and other scenes that need to reverse, you can enable the tracking function, which can automatically control the steering and speed, and help you reverse according to the original path to relieve you from the difficult scene. Note: The tracking function can be used when the valid memory path length is more than 1 meter and the road width of the vehicle is greater than 3 meters.

Tip: When other intelligent driver assistance systems are running, the tracking function cannot silently remember the path, or the function cannot be used because of the unavailability of valid memory path.

The tracking function assists reversing by the following steps:

1. Methods to enable the function:

Method 1: Click the "Traceback" button on the 360 interface to enable the function and enter the function interface;

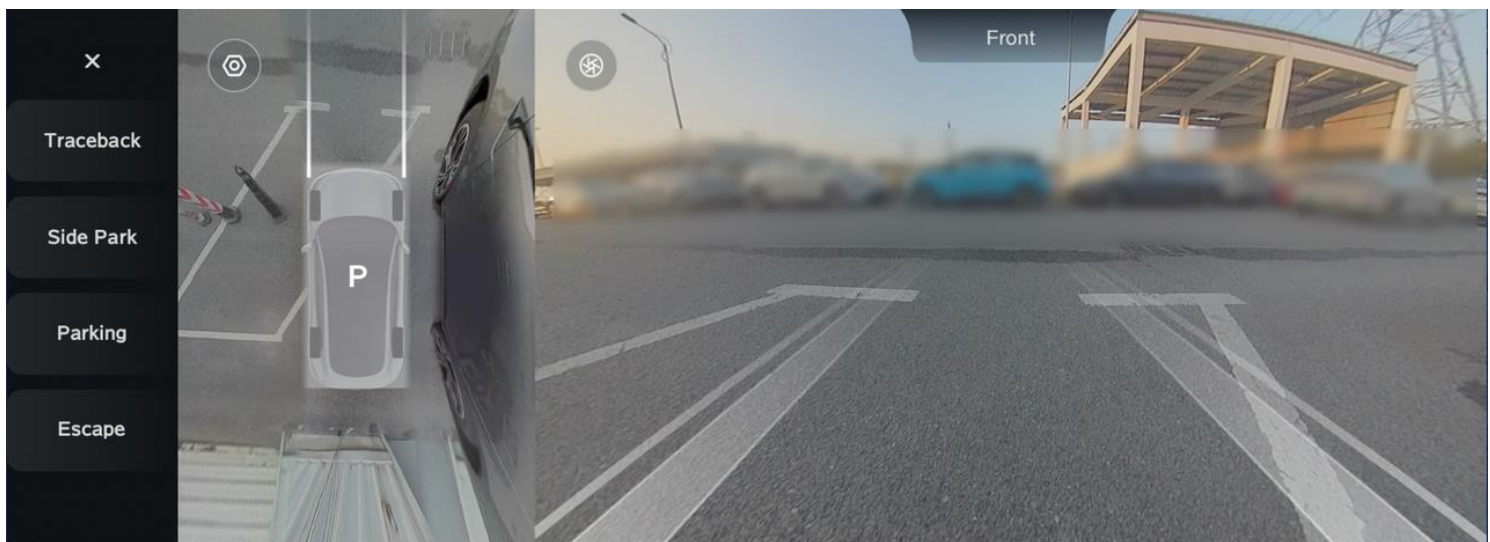

Method 2: Click the "OTT" button on the HOME interface of the central screen to enable the function and enter the function interface;

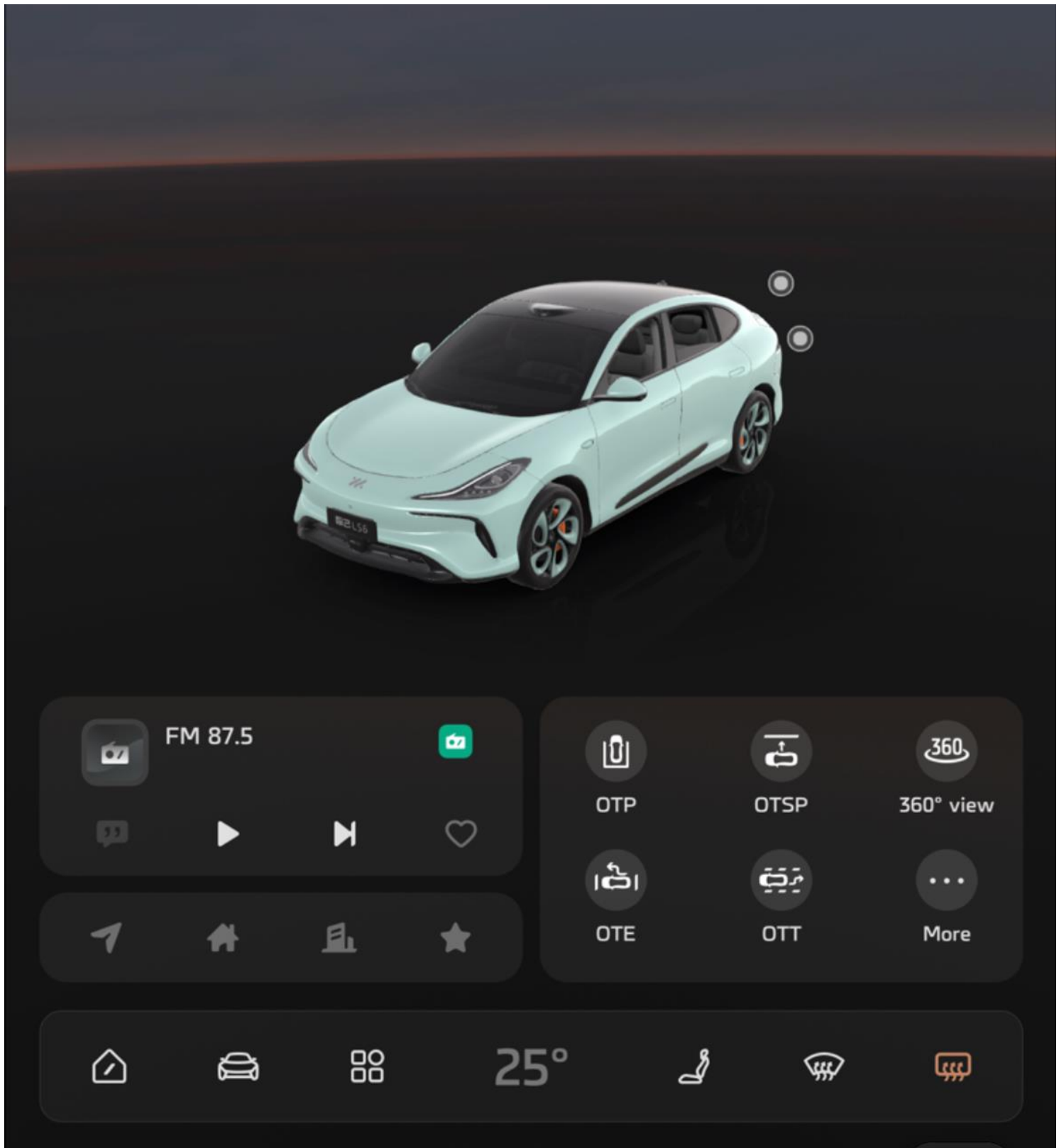

Method 3: Click the “Traceback ” button in One Touch iAD on the APP menu interface of the central screen to enable the function and enter the function interface.



After entering the tracking function interface, stop the vehicle and keep braking, then you can see the total length of the expected tracking process and click“Reverse”to follow the operation prompts on the interface.

2. Run the function:

During tracking, the remaining tracking distance will be displayed in real time. The function will automatically control the steering and speed of the vehicle, but you still need to keep an eye on the surroundings to be ready to take over and ensure the safe tracking. When it is about to reach the end of the tracking, the interface will prompt in advance: It is about to reach the end.

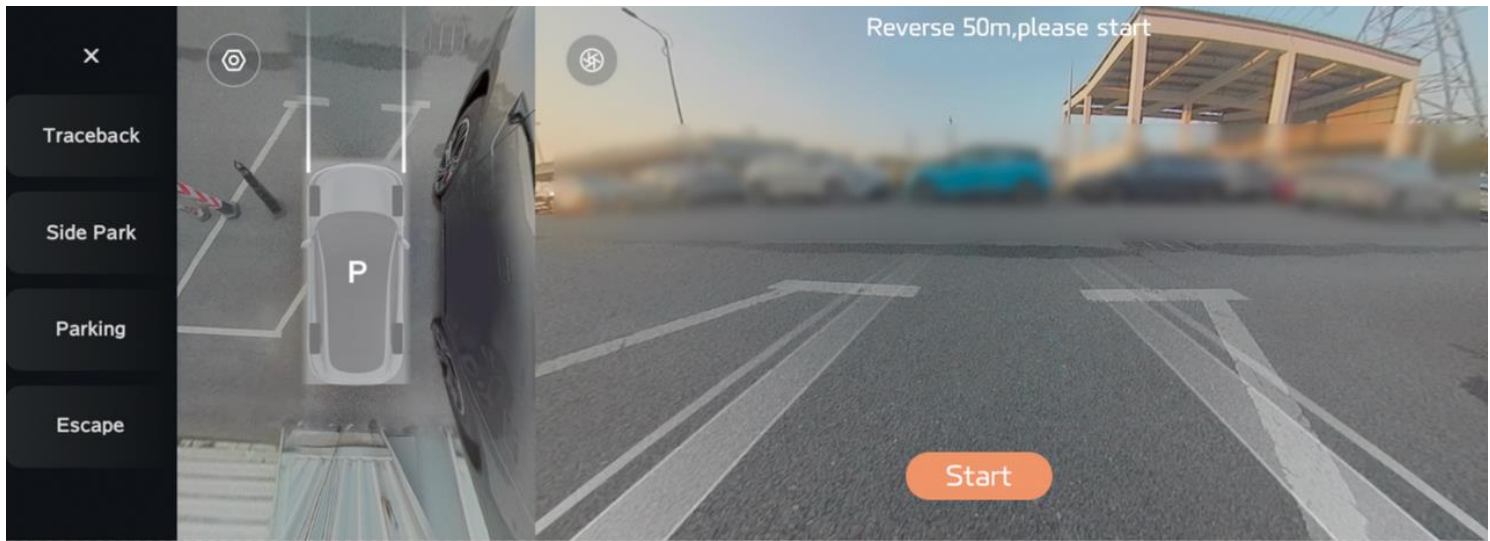

3. Complete the function:

The reverse by tracking is completed when the function controls the vehicle to automatically reverse to the end of memory path. After the function is completed, it will automatically engage your vehicle in P gear, and prompt: Tracking Completed.

Pause and exit of the function:

1. The tracking function will be paused in the following cases:

- ① Click [Pause] button in the function interface;
- ② Depress the brake or open the door;
- ③ The time from brake to stop exceeds a certain period of time due to obstacles.

After the function is paused for a certain period of time, you can still click the [Continue] button in the function interface to continue the tracking operation.

2. The tracking function will be exited in the following cases:

- ① The driver intervenes with the driving
 - Turn the steering wheel
 - Move the shift lever
- *The function has no response when the throttle is depressed;
- ② Click [Exit] button in function interface (available only when the function is paused);
 - ③ The function is paused for more than 1 minute due to obstacles;
 - ④ Abnormalities such as system failure.

Instructions for Using One Touch Traceback

Warning: You should understand that this system is only designed to assist the driver in reversing, and the driver is still the main operator, and should comply with national and local traffic safety regulations, and be responsible for the safety of the entire reversing process. You should judge the use of the system based on the overall environment (such as weather, geographical environment, etc.), and assume the corresponding responsibility for your judgment.

- The system performance depends on the ability of ultrasonic sensor and surround view cameras to detect and recognize the environment. The user is required to monitor the vehicle safety in real time, and take over the vehicle if necessary to ensure the safety of the vehicle and surroundings.
- Currently, the sensor cannot identify hanging, small, and narrow obstacles. If there are such obstacles in the environment, please watch out and ensure that the environment is suitable and safe, and be ready to intervene at any time to take over the vehicle to avoid a collision.
- Keep the rearview mirror unfolded when using the function to ensure that the left/right camera operates properly.
- If the surface of the camera is stained or blocked, the perception capability will be affected, resulting in failure to identify the surroundings. Please clean the camera in time.
- During the operation of the function, due to the blind spot of the perception system, it will not be able to timely detect and identify the vehicles passing in front and at the back or the pedestrians approaching quickly, resulting in failure to stop and avoid in time.
- There is a certain tracking deviation in the reversing process, which may deviate from the original driving path, in order to avoid the risk of scratch or collision, the user shall monitor the safety of the vehicle in real time, and take over if necessary to avoid scratch accidents between the vehicle and the surroundings.

Function Limitation and Errors:

The tracking function may not operate properly in the following cases

1. Dark or low environments will significantly reduce the sensor's perception capability, which can affect the smooth operation of the function.
2. Rainy, foggy, snowy or extremely cold or hot and other adverse weather environments will significantly interfere sensor's perception capability, which can affect the smooth operation of the function.
3. When other intelligent driver assistance functions are working, the tracking function cannot be enabled.
4. The obstacles within 30cm of the body are in the blind spot of perception. When there are obstacles within 30cm around the body, do not enable the function to avoid scratch accidents between the vehicle and the surroundings.
5. The operation of the function requires sufficient road width. Reversing in a road with a width less than 3 meters will cause the function to interrupt and exit.
6. The sensor cannot identify the road with height difference, so do not use the function on the road with cliffs and steps to avoid accidents.
7. The sensor cannot detect potholes, ditches, or uneven obstacles on the road. If such obstacles exist in the path for reversing, do not enable the function to avoid safety risks.
8. The function does not work when driving on ramps.
9. The function cannot work successfully and exit due to sharp turning curves or extreme small turning radius.
10. The function does not work when the valid memory path is less than 1 meter.
11. If the tracking function is exited in the middle, the system will clear the memorized route, and the function cannot be re-enabled to continue the remaining path.
12. The system will clear the path that has been memorized, resulting in failure to enable the function in the following cases, including but not limited to: driving at a speed greater than 25 km/h, the steering wheel angle is too large, the vehicle is powered off, and other intelligent driver assistance functions are activated.
13. When the steering wheel angle is too large, it will cause failure of the function to work, so please try to correct the steering wheel before enabling the function.

The warnings, limitations, or error examples above do not cover all of the conditions that may affect the proper operation of the tracking function, therefore the driver must remain attentive when using the function, and take full responsibility for the safety of vehicle and surroundings during the tracking at all times.

Rear Collision Assist System

Rear Collision Assist System

On the central screen, you can enable the rear driver assistance (RDA) system and set each sub-function.

Controls

Light

Lock

Adjustment

Driving

ADAS

Connection

Sound

Display

General

×

Rear Collision Assist

Rear Collision Assist



Blind Spot Warning



Door Open Warning



Rear Side Coming Assist

Off

Warning

Break

Off

Warn

Warn+Assist



25°



Blind Spot Warning

The blind spot warning includes two active safety assist functions, Blind Spot Detection (BSD) and Lane Change Assist (LCA), which are intended to alarm the driver, vehicles at the oblique rear and side of your vehicle, providing assistance in multi-lane co-direction traffic conditions.

The Blind Spot Detection (BSD) alarms the vehicles in the blind spot of your vehicle (1) the Lane Change Assist (LCA) alarms the vehicles approaching quickly with a potential collision risk in the adjacent (2).

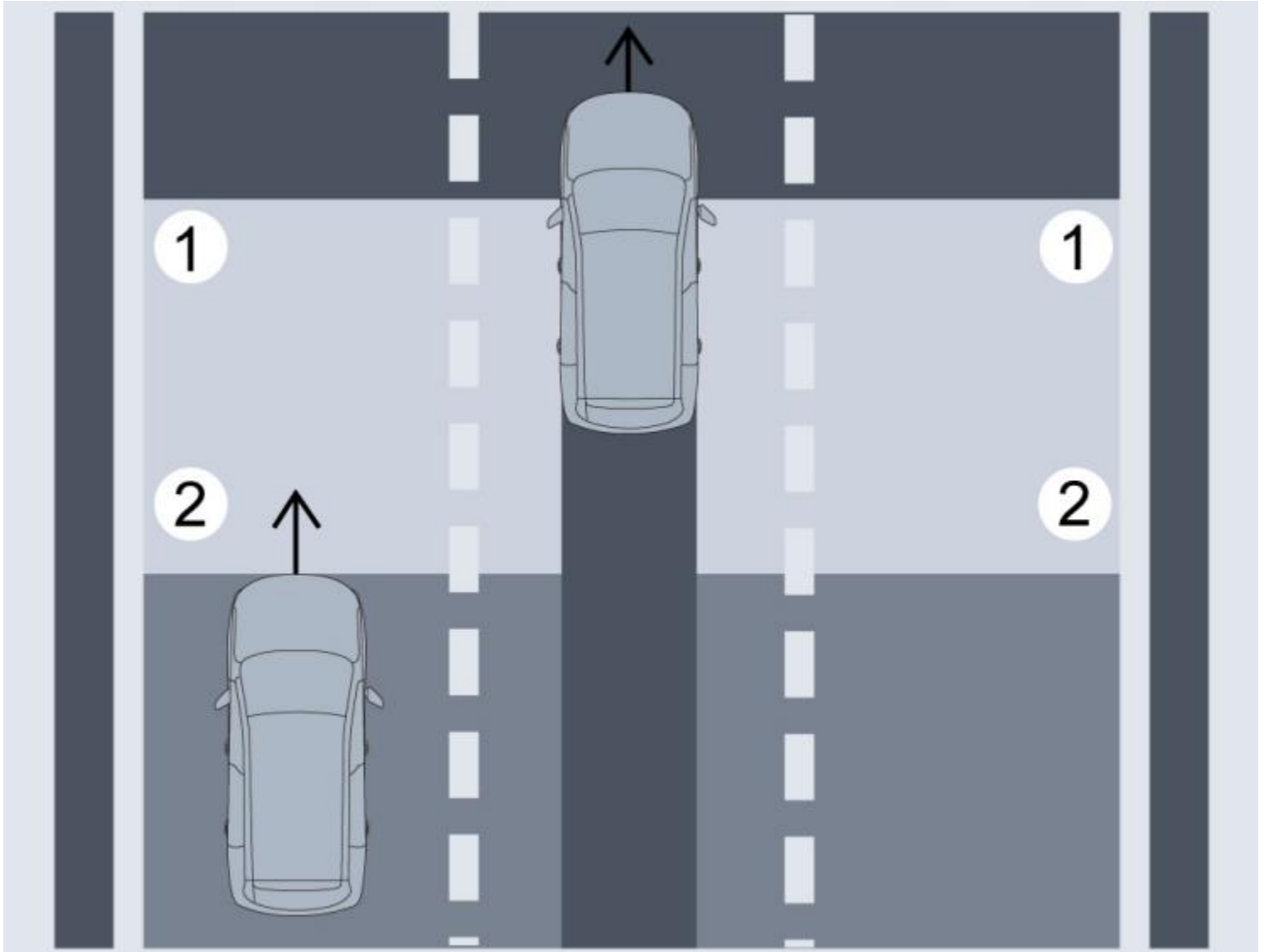

During driving (at a speed over 15 km/h), when the system detects a vehicle running in the blind spot of the rearview mirror of your vehicle or a vehicle approaching behind the adjacent lane, the breathing lamp at the corresponding side of driver A1 screen will illuminate. If the direction indicator lamp at the same side is turned on, the breathing lamp at the corresponding side of driver A1 screen will flash, warning the driver that it is dangerous to continue changing lanes.

Rear Side Coming Assist

Rear side coming assist includes Rear Cross Traffic Alarm (RCTA) and Rear Cross Traffic Brake (RCTB). During reversing, the RCTA monitors the vehicles approaching from the left, right and rear of your vehicle through a sensor, and gives alarms when there is a risk in reversing. The RCTB is an extended function of RCTA. In addition to giving alarms, the system will perform emergency brake to avoid the risk of collision if the driver fails to take safety measures.

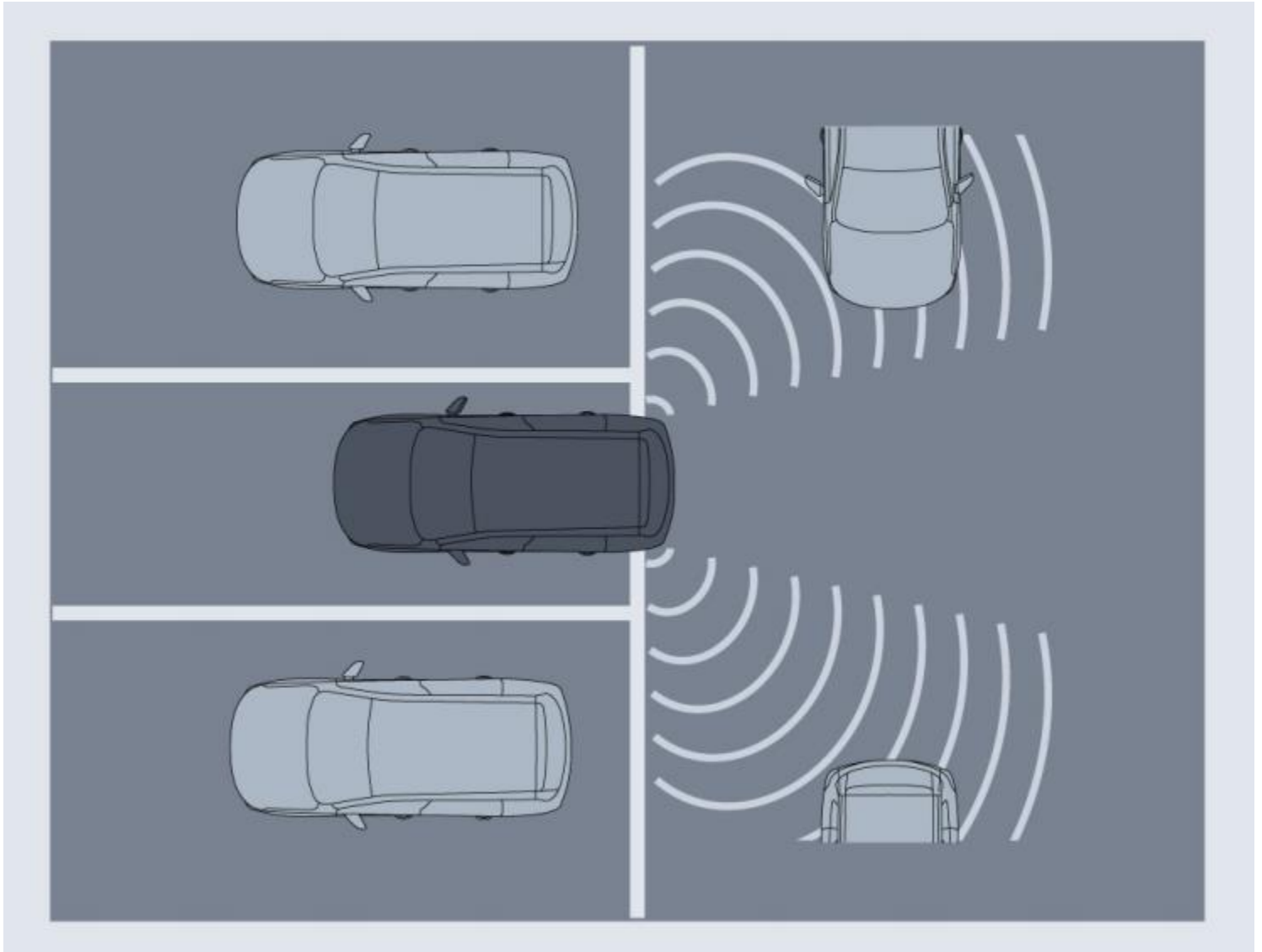

When there is a risk in reversing, the warning lamp at the corresponding side illuminates, with warning messages responded on the driver screen A2. If the driver fails to take safety measures, the system will perform emergency brake.

Door Open Warning

When opening the door, if there is a vehicle passing behind, Level 1 warning will be triggered before the door is opened, the breathing lamp at the corresponding side of driver A1 screen will illuminate; Level 2 warning will be triggered after the door is opened, and the breathing lamp at the corresponding side of driver A1 screen will flash.

Important Instructions for Using Rear Collision Assist System

- Specific roadside buildings (such as high or oblique guardrail), weather conditions, weight of loads on the vehicle, road conditions (such as road bumps or sharp turns), coverings on the car, etc. will affect the recognition effect of the rearward driver assistance system sensor, thus the false alarm may be issued.
- The system may not be able to warn the driver of the vehicles that are approaching very fast from the rear or warn the driver when the vehicle runs around the curve with small turning radius.
- The system cannot work properly when a towing device is attached.
- The rear driver assistance system can only assist the driver to observe the surrounding environment and the driver should always focus attention, observe the surroundings of the vehicle and drive safely.
- The radar sensor in the rear bumper may be misaligned or damaged by a collision, and the system may be affected or automatically turned off.
- Do not paste any object on the warning lamp to avoid affecting the warning function of the system.
- To ensure that the radar sensor works properly, the rear bumper should be kept free of snow and ice and must not be covered.
- The rear bumper is only allowed to use automotive paint certified, otherwise the system functions may be restricted or defective.

Smart Safety Assist

Speed Limit Information Function (SLIF)

Speed limit information function (SLIF) is an assist function of speed limit reminder. The system can recognize the road speed limit sign, and provide the current speed limit information to the driver through the instrument. If the vehicle exceeds the current road speed limit value, the system will alarm in time, in order to assist the driver for compliant driving.

SLIF interface is on the central screen: Enter the “Intelligent Drive” option, and roll over the pages to find the “SLIF Settings” interface.

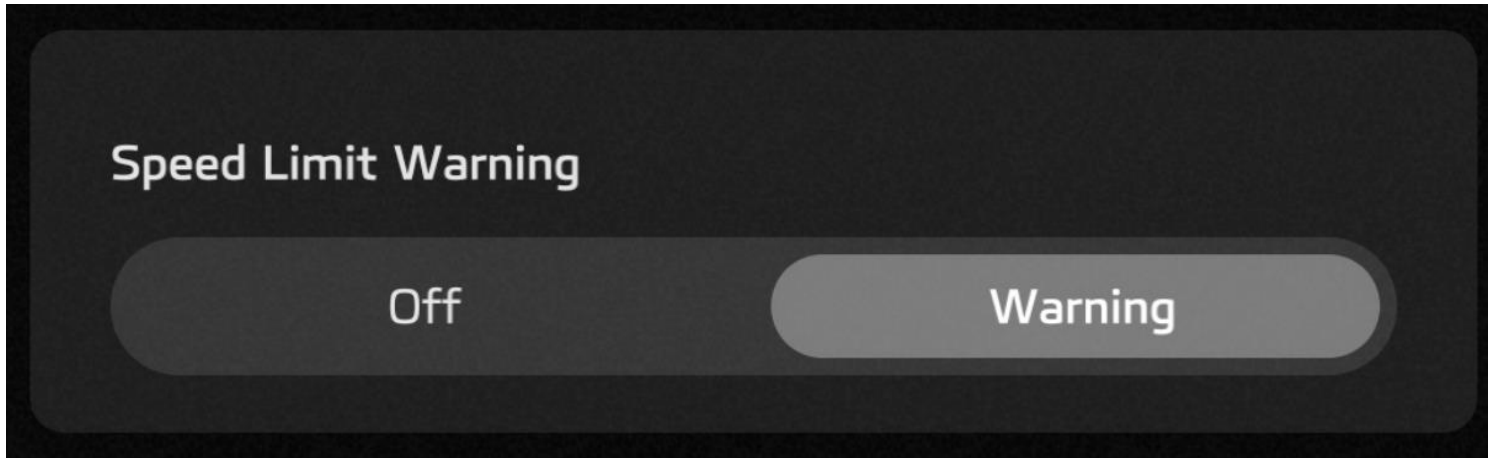

Important Instructions for Using SLIF

Warning: SLIF, as an assist function, may cause incorrect speed limit value or no speed limit value to be displayed on the instrument pack due to environmental factors or the system itself, so the driver still needs to observe the speed limit regulations of the road traffic and shall be prohibited from overspeed driving.

The use of SLIF may be limited in the following conditions, but not limited to:

- The vehicle is driven at a high speed;
- There are several speed limit signs set up over the road or at the roadside; Currently, the front view camera can only identify the speed limit signs for the lane the car drives on, different speed limit signs for different models, and the speed limit signs with additional information;
- The speed limit signs set up at the fork in the road, curve and on-ramp/off-ramp;
- Lane change, etc.
- Affected by poor lighting conditions, bad weather, non-standardized or sheltered speed limit signs or the camera's own restrictions, the camera may not recognize all speed limit signs or make error recognition (e.g., recognize the weight limit sign as a speed limit sign, recognize the minimum speed sign as the maximum speed sign).
- The camera cannot identify the texts provided below the speed limit sign, such as Auxiliary Lane, 100m Ahead, School Section, 7:00-10:00 etc.
- Some drastic and rapid steering operations of the driver may be judged as changing lane or turning around in the intersection by the system, resulting in the identified speed limit signs being cleared.

IMPORTANT

The front view camera cannot identify the speed limit signs painted on the road surface, so the driver still needs to observe the speed limit requirements on the road surface in real time. When the vehicle needs to change lane or make a turn or turn around in the intersection, if the driver turns on the turn signal light in advance and slows down, the original speed limit value on the instrument pack will be cleared till a new speed limit sign is detected; if such conditions are not met, the original speed limit value will be kept. The driver should make judgment at his/her discretion.

Full-speed Adaptive Cruise Control System

Full-speed Adaptive Cruise Control System

Depending on whether there is a vehicle ahead, the full-speed adaptive cruise control system can conduct automatic switching between constant speed cruise and car-following cruise.

With the full-speed adaptive cruise control system, the vehicle is allowed to conduct constant speed cruise within a certain speed range, or conduct car-following cruise by setting the distance between the vehicle and vehicles ahead.

If a vehicle is detected in your driving path, the full-speed adaptive cruise control system may apply moderate brakes or acceleration to maintain the selected following distance.

Activation of Adaptive Cruise Control

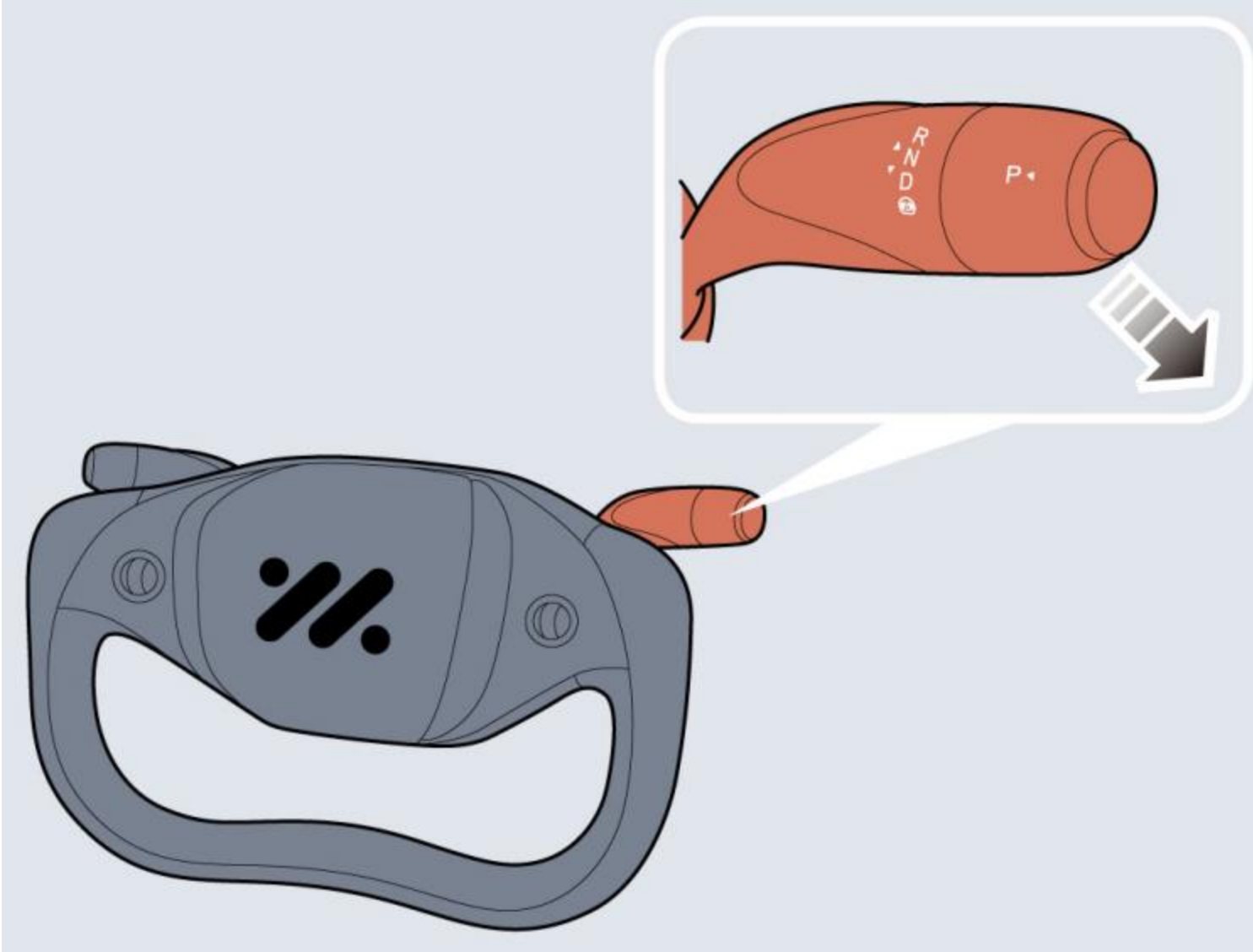

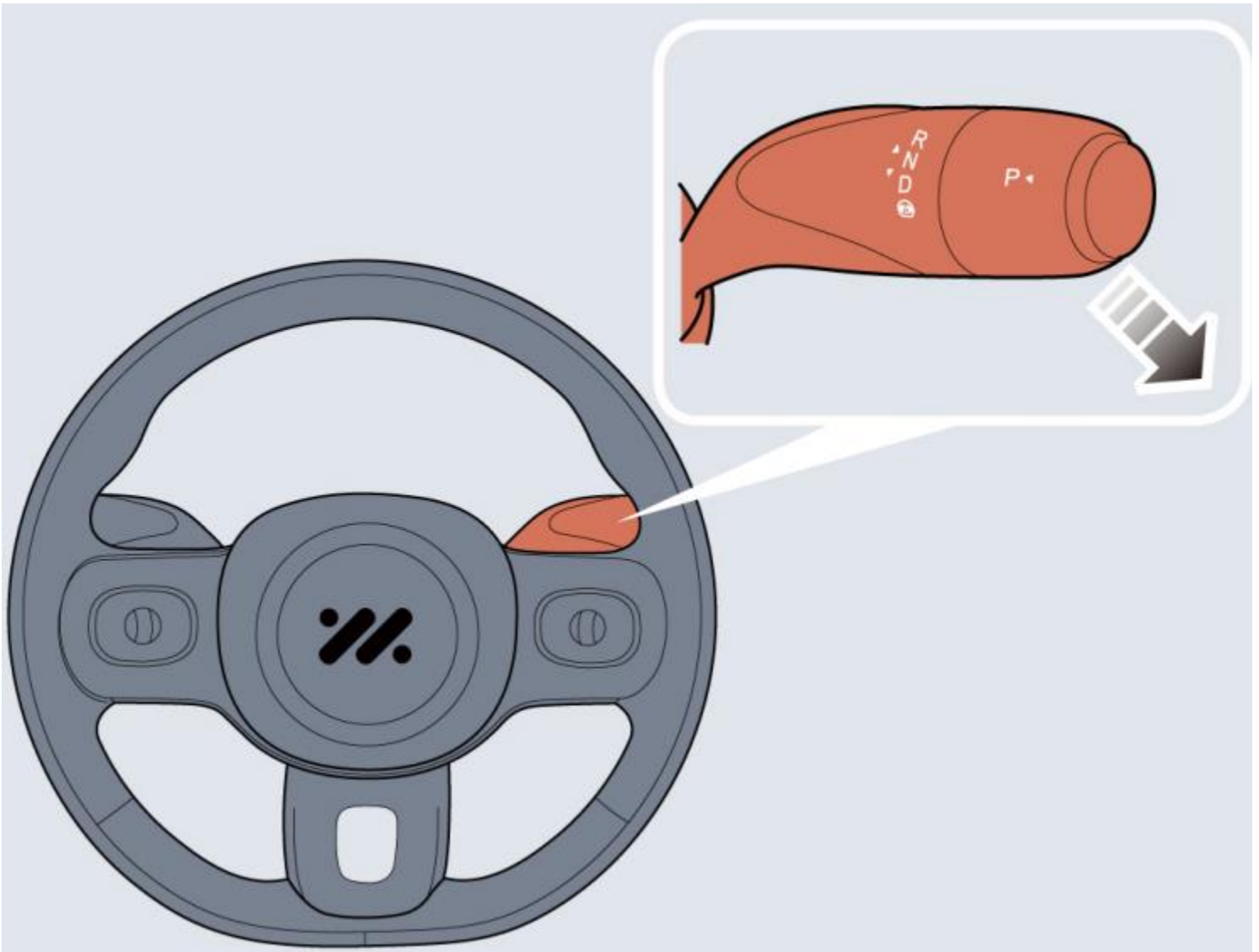

The adaptive cruise control system is activated by fully pulling down the shift level once when the following conditions are met:

1. The gear is in D;
2. The electronic parking brake is released;
3. Four doors and two covers are closed;
4. The seat belt is fastened;
5. The adaptive cruise control switch on the entertainment display is turned on;
6. The speed should be greater than 0 km/h if there is a vehicle ahead; the speed should be greater than 10 km/h if there is no vehicle ahead.

After successful activation, the indicator light of the adaptive cruise control system on the instrument pack will turn blue, its target speed is the actual speed at activation (if your vehicle speed is less than 30 km/h, the target speed of the system is set at 30 km/h), and the set speed range is 30 to 120 km/h. If the speed of the vehicle ahead is greater than the cruise target speed of your vehicle, your vehicle will maintain the target speed to conduct constant speed cruise; if the speed of the vehicle ahead is lower than the cruise target speed of your vehicle, it will enter the car-following cruise, and the tail schematics of the vehicle ahead is displayed on the instrument pack. In the car-following cruise, you can follow the vehicle ahead to a stop. If the stop time is less than 90 seconds, your vehicle will automatically start off to follow the vehicle ahead, otherwise the driver needs to restore the adaptive cruise control system according to the instrument prompt; if the car-following stop lasts for more than 10 minutes, the adaptive cruise control function will exit.

Adjustment of Target Speed

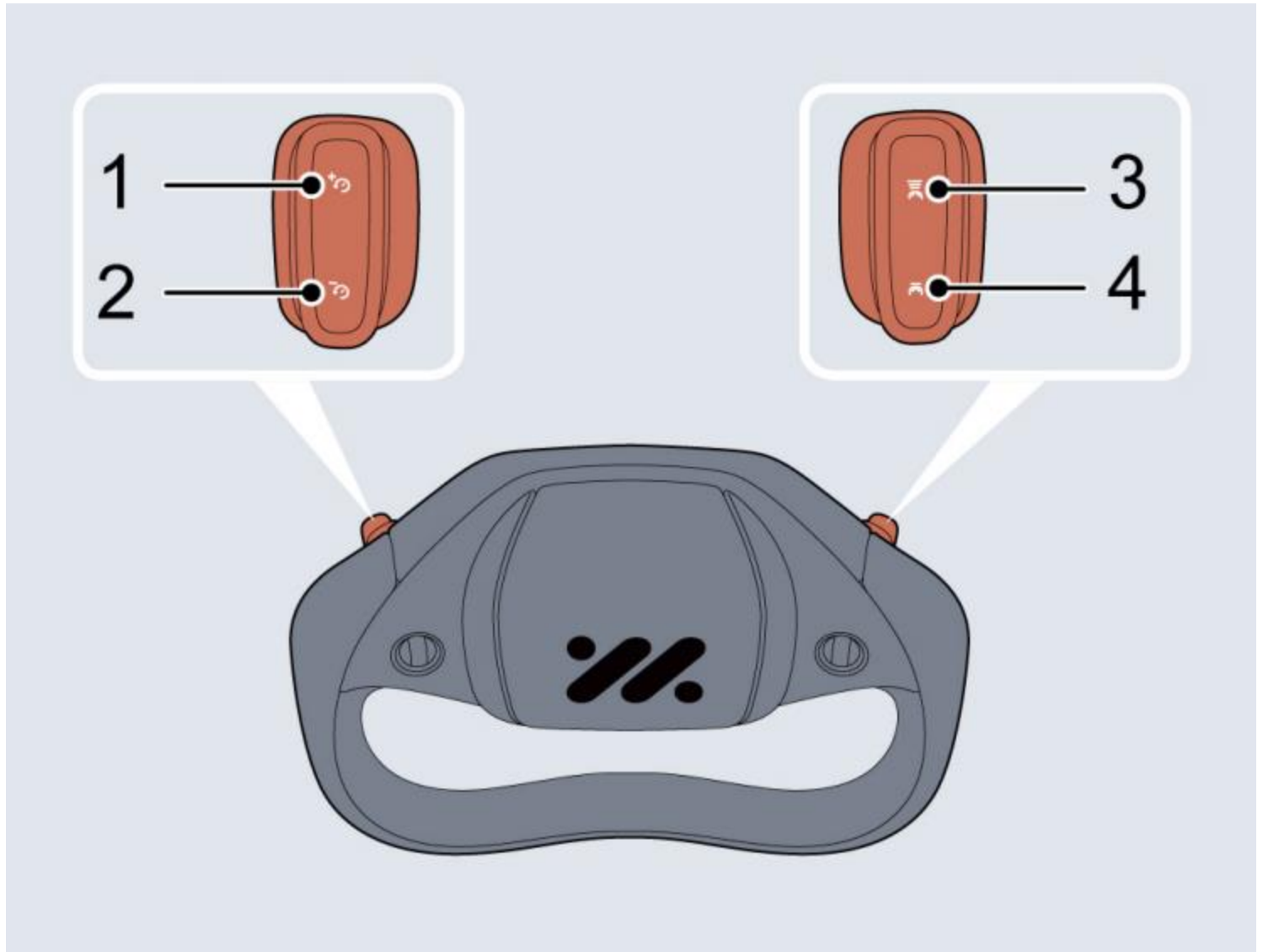

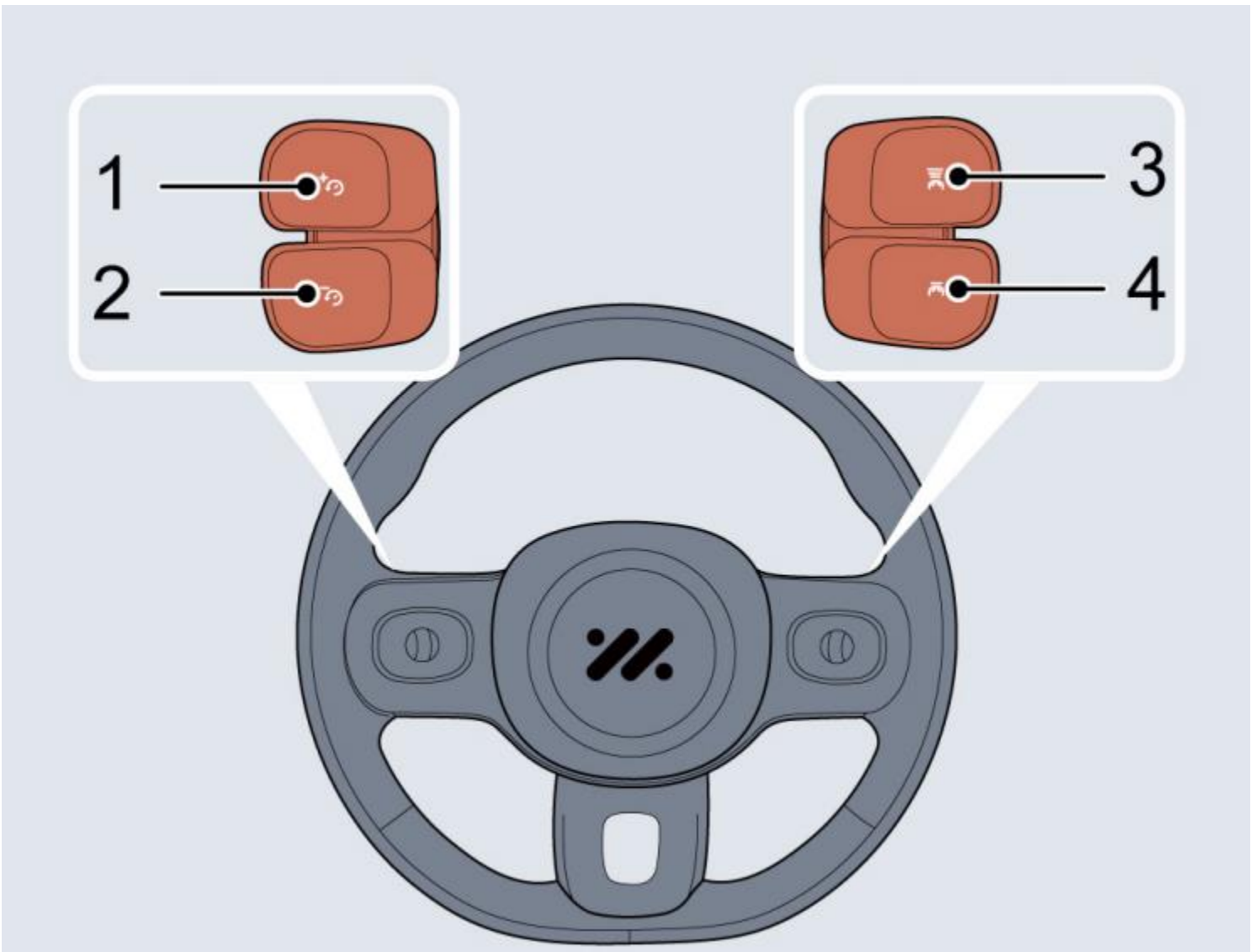

When the adaptive cruise control system is active:

- Use the accelerator pedal to reach the desired speed, and fully pull down the shift level, the vehicle will cruise at the desired speed.
- Move the upper adjustment paddle on the left of steering wheel (1) and hold, the target speed will increase until the desired set speed appears on the instrument pack, and then release the paddle. When it is confirmed that there is no vehicle ahead or the vehicle ahead is beyond the pre-selected following distance, the vehicle speed can be increased to the set speed.
- Move the lower adjustment paddle on the left of steering wheel (2) and hold, the target speed will decrease until the desired set speed appears on the instrument pack, then release the paddle, and the speed will decrease to the set speed.
- When adjusting the target speed with the adjustment paddle, the target speed is changed by 5 km/h each time the paddle is moved briefly; when moving the paddle and holding, the target speed will increase or decrease at a change rate of 1 km/h until the paddle is released.

Adjustment of Following Distance

When the adaptive cruise control system is activated, move the upper adjustment paddle (3, for increasing the distance) or lower adjustment paddle (4, for decreasing the distance) on the right of steering wheel to adjust the following distance, switch among 5 distance settings, and display it on the instrument pack.



The following distance is not constant and will change with the speed, which will become longer when the speed is high. Considering the traffic and weather conditions, the optional following distance range may not be suitable for all drivers and driving conditions.

Cancellation and Restoration of Adaptive Cruise Control

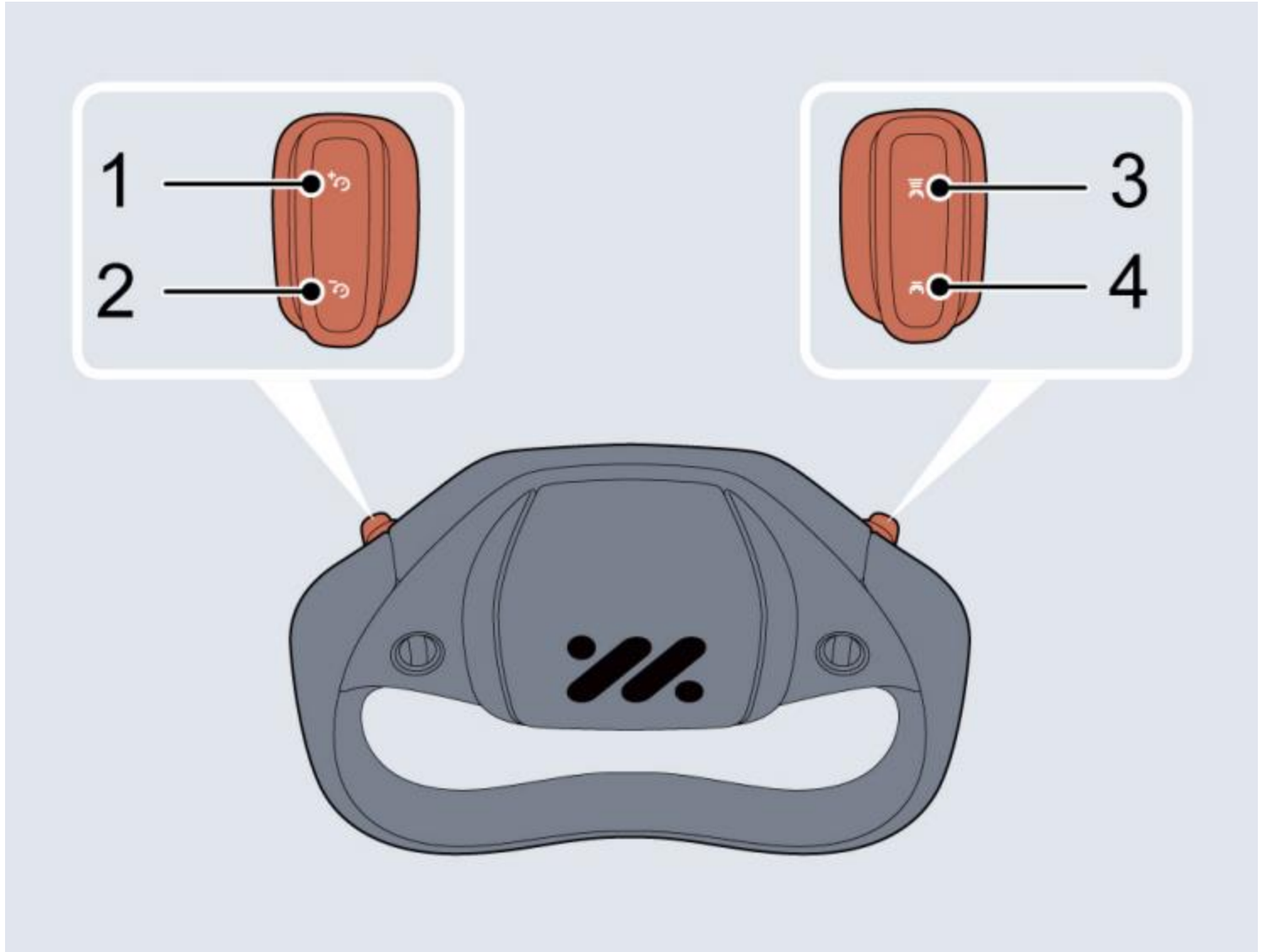

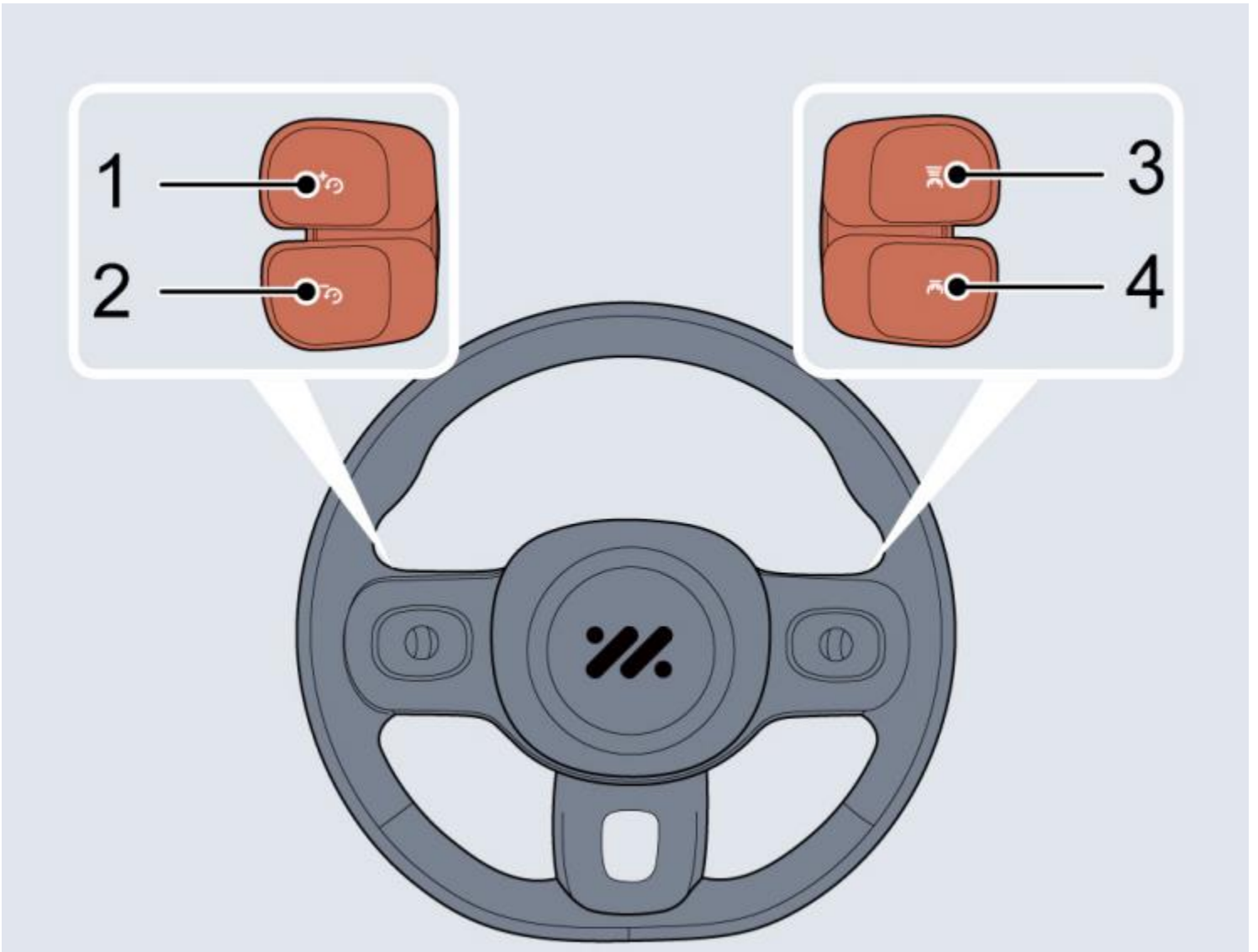

When the adaptive cruise control system is active, fully pull up the shift lever to cancel the function.

If the adaptive cruise control system is not activated for the first time within the vehicle start cycle, it may be reactivated by moving the upper adjustment knob (1) on the left of steering wheel. In this case, the target cruise speed is the target speed before exiting the adaptive cruise control system.

Automatic Deactivation of Adaptive Cruise Control

- Depress the brake pedal when the vehicle is not stationary;
- Move the shift lever to any gear other than Drive gear;
- The driver unfastens his/her seat belt;
- Depress the accelerator pedal for a long time;
- Any door or the bonnet/tailgate is opened while driving;
- Pull up the electronic parking brake switch;
- The vehicle is stopped for more than a certain time;
- The camera or radar is blocked, or surroundings trigger the safe exit mechanism of sensor, or the system fails.

Important Instructions for Using Adaptive Cruise Control

Warning: Adaptive cruise control system, designed for achieving the driving comfort, can provide assistance for the driver but cannot replace the driver in driving. When the adaptive cruise control system is applied, the driver should always pay full attention and prepare for taking measures at all times, otherwise the accident or personal injury may occur.

Warning: The adaptive cruise control system is suitable for using on the expressways and the roads in good condition, but not on the urban roads or mountain roads.

Warning: After following the vehicle ahead to a stop with the adaptive cruise control system, the driver must ensure that there are no obstacles or other traffic participants (such as pedestrians) directly in front of the vehicle before starting off to follow the vehicle ahead again.

Warning: During the car-following cruise, it is not recommended to put your foot on the accelerator pedal. If the accelerator pedal is depressed, the adaptive cruise control system cannot automatically apply the brake to the vehicle, since the vehicle is only controlled by the driver's manipulation of the accelerator pedal in this case, and the system does not work.

Warning: DO NOT leave the vehicle while it is kept stopped by the adaptive cruise control system. Before leaving the vehicle, always shift to P gear and turn off the Start switch.

Warning: The driver should pay full attention and be prepared to apply the brakes even if the vehicle is kept stopped by the adaptive cruise control system. Please note that the vehicle will no longer remain stationary and may move forward or slip on slope if the system is deactivated, turned off or canceled at this time.

Note: When driving on a curve, the adaptive cruise control system may actively reduce the vehicle speed to ensure driving safety.

Note: If the vehicle ahead makes harsh acceleration or deceleration frequently, the adaptive cruise control system may be unable to maintain the following distance accurately; in this case, the driver shall make appropriate operations such as depressing the brake pedal or changing the lane according to the surrounding traffic and road conditions.

Note: If the driver actively depresses the accelerator pedal when the adaptive cruise control is active, the speed will be controlled by the accelerator pedal, and the system will not automatically decrease the speed, requiring the driver to control a safe distance. With the accelerator pedal released, the adaptive cruise control system will resume to the preset target cruise speed.

The adaptive cruise control system is limited or does not work even if it is enabled in the following conditions:

- Encounter a vehicle or object which is stationary or traverses the lanes (including but not limited to traffic cones, water-filled barriers, construction warning signs, etc.);
- Approach the vehicle ahead so fast that the system cannot apply sufficient brakes;
- There is oncoming traffic or the vehicle ahead applies emergency braking;
- The vehicle ahead reverses;
- A vehicle suddenly cuts into the lane in front;
- Encounters a vehicle driving at a low speed;
- Encounters a vehicle with loaded items protruding from the body contour;
- Encounters a vehicle with a higher chassis (e.g., a truck);
- Encounters pedestrians, non-motor vehicles or animals;
- The vehicle is driving on an uneven road or a complex traffic road section;
- The vehicle makes a sharp turn;
- The vehicle is passing through a tunnel or driving in the tunnel;
- The vehicle is driving under the mottled tree shadow;
- Overload at the cargo area causes the vehicle head tilting upward.

Special driving environments:

If the adaptive cruise control system is used in the following special driving environments, the driver shall pay special attention to surroundings, select suitable speed and be prepared to take measures at all times:

- When turning at the intersection or driving into or out of the curve following the vehicle ahead, the adaptive cruise control system may be unable to detect the vehicle ahead on the same lane, or may respond to the vehicles in another lane.
- If the vehicle ahead changes the lane, but not driving into the new lane completely, the adaptive cruise control system may be unable to detect the vehicle.
- If the vehicle ahead changes the lane, but does not exit the original lane completely, the adaptive cruise control system may determine that the vehicle ahead has already left and accelerates.
- When driving on a steep slope, the adaptive cruise control system can not detect the vehicle in the same lane, so please do not use the adaptive cruise control system.
- When driving at a small body width overlap ratio with the vehicle ahead, the adaptive cruise control system may be unable to detect the vehicle.

Note: It is recommended to turn off the adaptive cruise control system in the following situations:

- Drive in bad weather;
- The surrounding ambient light is insufficient or excessively sufficient, or the front lighting of your car is poor;
- Drive on poor road section;
- Drive through road construction site;
- Driving on the low-friction road (the rapid change of the tyre traction may result in the excessive wheel slip).
- Driving on the entry-exit road or sharp curve.

Pilot

Pilot

The Pilot works on the basis of the adaptive cruise control system. If the lane lines ahead on both sides are clear, the system will assist the vehicle in driving within the lane lines; if there is a vehicle ahead and the lane lines are not clear, the system can assist the vehicle in following the track of the vehicle ahead.

IMPORTANT

The driver shall adjust the vehicle speed and the following distance according to the road visibility, weather and road conditions. The Pilot has reduced response to pedestrians, stationary vehicles, vehicles crossing the lane or oncoming vehicles in the same lane. If the Pilot cannot fully reduce the vehicle speed, the driver shall apply the brake by depressing the brake pedal. If another vehicle cuts into the current lane under congested conditions, the system may not brake timely due to the fact that the cut-in vehicle does not enter its detection range, and the driver shall actively apply the brake.

Activation and Deactivation of Pilot

When the following conditions are met:

- The Pilot switch on the entertainment display is on;
- The system recognizes clear lane lines on both sides;
- The vehicle is in Drive gear;
- The electronic parking brake is released;
- Four doors and two covers are closed;
- The seat belt is fastened;
- The brake pedal is not depressed;
- The relevant systems work normally;
- The speed should be greater than 0 km/h if there is a vehicle ahead; the speed should be greater than 10 km/h if there is no vehicle ahead.

The Pilot can be activated by fully pulling down the shift lever. After successful activation, the indicator light of the Pilot on the instrument pack will turn blue, and its target speed is the actual speed at activation (if your vehicle speed is less than 30 km/h, the target speed of the system is set at 30 km/h). If the speed of the vehicle ahead is greater than the target speed of your vehicle, your vehicle will maintain the target speed; if the speed of the vehicle ahead is less than the target speed of your vehicle, your vehicle will enter the car-following mode and follow the vehicle ahead to a stop. If the stop time is less than 90 seconds, your vehicle will automatically start off to follow the vehicle ahead, otherwise the driver needs to restore the Pilot according to the instrument prompt; if the car-following stop lasts for more than 10 minutes, the full-speed driver assistance function will exit.

When the system detects that the driver does not hold the steering wheel continuously in a certain period of time, it will give warnings to prompt the driver. If the steering wheel is not held for a certain period of time, the system will automatically exit and the seat belt will vibrate. If the Pilot needs to be activated again, please follow the prompts on the instrument pack.

Automatic Avoidance

If your vehicle detects a large vehicle in the adjacent lane of the current driving path, it can be controlled to perform a slight lateral avoidance in the current lane to increase the lateral safe distance.

Important Instructions for Using Pilot

Warning: The Pilot is an auxiliary system, which can provide assistance to the driver but cannot replace the driver in driving. Due to the limitations of system detection and control when using the Pilot, the driver must always hold the steering wheel, pay attention to the surrounding environment of the vehicle, and correct or take over the steering wheel control when necessary, otherwise accidents or personal injuries may be caused.

The Pilot will be limited or does not work in the following conditions:

- The driver presses the accelerator pedal rapidly, makes emergency steering or presses the brake pedal hard;
- The system recognizes that the driver does not manipulate the steering wheel for a period of time;
- When the system implements the control, the driver is manipulating the steering wheel;
- The lane line is too thin, damaged or fuzzy;
- The vehicle is driving on the curve with a small curvature radius or on too narrow or too wide road;
- The vehicle has just entered the road section with lanes or has passed the road section without lane lines;
- The driver actively controls the lane change or the lateral sway is too fast;
- When driving along the track of the vehicle ahead, the turning radius of the vehicle ahead is too small;
- The anti-lock brake system (ABS) and the dynamic stability control system (SCS) are activated;
- The anti-lock brake system (ABS), dynamic stability control system (SCS), electric power steering system (EPS), etc. fail.
- Encounter a vehicle or object which is stationary or traverses the lanes (including but not limited to traffic cones, water-filled barriers, construction warning signs, etc.);
- For other constraints, refer to the "Constraints of Adaptive Cruise Control Function" section.

Note: For the half-width steering wheel, please pay special attention to the hand position on the steering wheel, since the non-standard hand position will also be considered as unattended, limiting the use of full-speed driver assistance function. Please hold the steering wheel in the recommend hand position as much as possible to ensure safe driving and intelligent driving experience.

Non-recommended hand position



Recommended hand position



It is not recommended to use the Pilot in the following situations:

- Drive in sports style;
- Drive in bad weather;
- Drive on poor road section;
- Drive through road construction site;
- When driving the vehicle on a steep, meandering road or slippery road (such as snow and ice road, wet road, road with puddle);
- When driving off-road or on an unpaved road.

The driver should be prepared to take over the vehicle at any time in the following situations:

- In the case of increased lanes, lane merges, etc., the driver is required to take active control.
- In the case of complex traffic conditions (such as intersections, road sections with traffic congestion, etc.), the driver is required to take active control.
- When driving along the track of the vehicle ahead with the function on, the driver should pay attention to the status of vehicles on both sides and behind, and take over the vehicle at any time.

Commanded Lane Change

Commanded Lane Change

When the Pilot function is activated and the driver sends a lane change request through the steering lever, the system achieves automatic lane change by controlling the accelerator, steering, and brake, etc. when it judges that the lane change conditions are met.

Activation and Deactivation of Commanded Lane Change

When the following conditions are met, the commanded lane change system will enable the vehicle to drive into the adjacent lane in the direction indicated by the lane change indicator, and display the entire process of lane change on the instrument pack:

- The Pilot works normally;
- The direction indicator lamp has been turned on;
- There is no intervening obstacle in the target lane;
- The lane marking indicates that lane change is allowed (the lane line is white dashed line or white dashed and solid lines with the inside of the current lane being dashed line);
- The system can detect the outer lane line of the target lane;
- The driving speed is 30 km/h~130km/h;

If the system detects that there is an intervening obstacle in the target lane, or the lane line in the lane change direction is non-white dashed line or the curvature radius of the road is too small during the lane change, it will enter the lane change process until the lane change conditions are met.

If the following situations occur during the lane change (without crossing the original lane line), the lane change will be canceled and the vehicle will return to the original lane:

- The driver toggles back the turn signal light lever to cancel the lane change request;
- There is a risk of collision with the vehicle approaching from behind in the target lane;
- The lane line on the outside of the target lane cannot be detected;
- The curvature radius of the road is too small

Important Instructions for Using Commanded Lane Change

Warning: The commanded lane change system is an auxiliary system, which can provide assistance to the driver but cannot replace the driver in driving. Due to the limitations of system detection and control when using the commanded lane change system, the driver must always pay attention to the surrounding environment of the vehicle, and correct or take over the steering wheel control when necessary, otherwise accidents or personal injuries may be caused.

Note: The commanded lane change can assist in driving into one lane at a time. To change lanes again, the direction indicator lamp should be enabled again after completing the first lane change.

Note: If the driver operates the steering wheel or depresses the brake pedal during the lane change, the lane change will exit.

Note: If the light or visibility is poor at night or the lane lines are not clear, the lane change may not be activated.

Note: If the camera is blocked or dirty, the ambient brightness changes suddenly, the camera mounting position is changed, or the camera recognition disorder may be caused in bad weather such as heavy rain or snow, the lane change cannot be activated.

Note: The commanded lane change may not recognize special vehicles, such as vehicles with the rear blocked or with irregular shape, and may miss stationary or slow-moving vehicles. Special attention should be paid to special scenarios such as at night and in rainy days.

Human-machine Co-driving

Human-machine Co-driving

Overview: In order to improve the use experience of intelligent driver assistance function, the steering wheel control can support human-machine co-driving (human-led control or intelligent drive system-led control) when the full-speed driver assistance function (hereinafter referred to as Pilot) are activated. That is, the user can control the steering wheel by actively applying force moment to control the driving direction of the vehicle. When the user cancels the applied force moment, the steering wheel control automatically recovers to the intelligent drive system control.

Operating range:

Vehicle speed: 0-130km/h;

Operating mode: Pilot activated when cruising in the lane.

During the activation of Pilot, when you actively control the steering wheel, the system will display the following indicators, and prompt with sound and messages “You are controlling the vehicle, please watch out”.



When Pilot is active, and the user actively controls the steering wheel.

Instructions for Using Human-machine Co-driving

Precautions

1. When the user is actively controlling the steering wheel, if the vehicle deviates too much from the lane lines, the intelligent driver assistance function will automatically degrade to the adaptive cruise control (hereinafter referred to as ACC). In this case, the ACC will no longer actively control the steering wheel, and the user needs to keep attention in driving and control the driving direction of the vehicle. After the vehicle returns to the middle of the lane, the intelligent drive function is automatically upgraded to Pilot;
2. The system does not support human-machine co-driving when the vehicle changes lane by turning on lamp and turning lever if the Pilot function is active, or when it enters the autonomous lane change process. (That is, in the process of lane change with intelligent driver assistance, if the user actively controls the steering wheel, the intelligent driver assistance function will be automatically downgraded to ACC. In this case, ACC will no longer actively control the steering wheel, and the user needs to keep attention in driving and control the driving direction of the vehicle. After the vehicle returns to the middle of the lane, the intelligent drive function is automatically upgraded to Pilot;
3. The human-machine co-driving function determines whether to respond to the steering wheel control of the user or of the intelligent driver assistance function by detecting the hand force moment, and it will enter human-machine co-driving state due to misjudgment if the user's hands apply heavy force on the steering wheel. Therefore, you need to pay attention to the road conditions at all times to avoid accidents, and you are recommended to hold the steering wheel with both hands;
4. When the human-machine co-driving is activated, the steering wheel control fully responds to the user control, in which case it is necessary to pay great attention to the surrounding traffic safety.

Lane Keeping Assist (LKA)

Lane Departure Assist System

The lane departure assist system switch is located on the central screen. The system can be turned on/off in the appropriate interface under "Intelligent Drive", and the mode selection can be made.

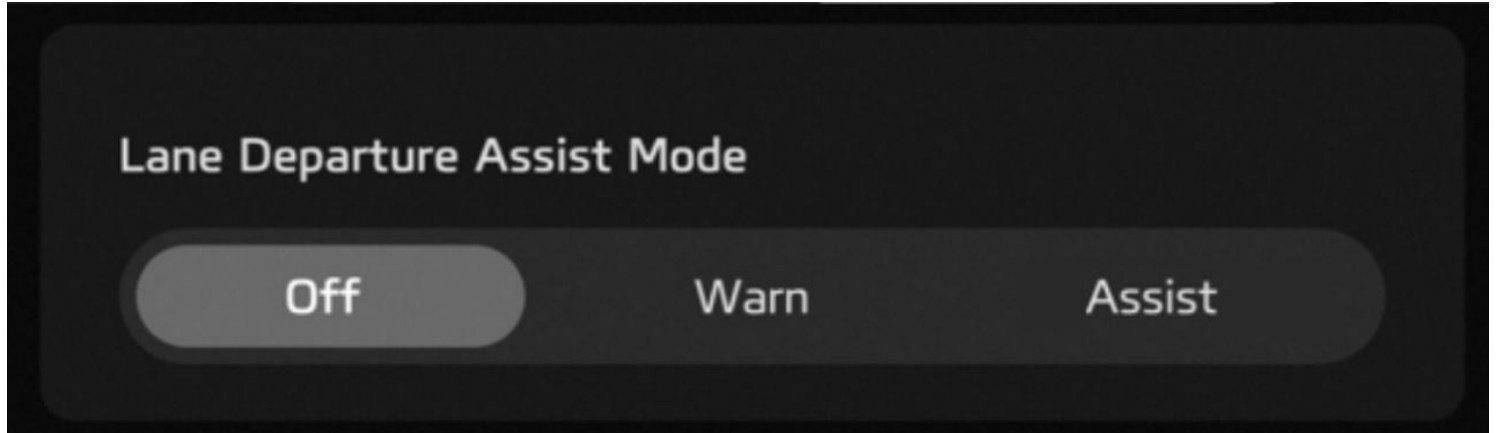

Warning

The system detects the lane lines ahead when the following detection conditions are met:

- The function is in ON state;
- The vehicle speed is above 60 km/h;
- The lane lines are clear, and the system detects the lane lines on both sides;

When the wheel is about to press the lane line or has already pressed the lane line, the system will give warnings to remind the driver to correct the direction in time and keep the vehicle running within the lane lines. The function will exit when the speed is less than 55 km/h.

Warning + Assistance

The system detects the lane lines ahead. When the following detection conditions are met:

- The function is in ON state;
- The vehicle speed is above 60 km/h;
- The lane lines are clear, and the system detects the lane lines on both sides;

If the vehicle is about to pass the lane line or run to the kerb, the system will assist the driver in keeping the vehicle running within the lane lines by applying corrective steering intervention and prompting. If the vehicle deviates too much from the lane line, the warning function will be triggered at the same time.

The function will exit when the speed is less than 55 km/h.

Important Instructions for Using Lane Departure Assist System

Warning: The lane departure assist system is an auxiliary system, which can provide assistance to the driver but cannot replace the driver in driving. When using the lane departure assist system, the driver should always pay full attention, hold the steering wheel, and be prepared to correct the steering wheel or take over the vehicle at all times, otherwise accidents or personal injuries may be caused.

Note: The lane departure assist system cannot always recognize the lane lines or kerbs, and sometimes may incorrectly recognize poor road surfaces, certain road structures or objects as lane lines or kerbs.

Note: In the case of increased lanes, lane merges, etc., the driver is required to take active control.

Note: In the case of complex traffic conditions (such as intersections, road sections with traffic congestion, etc.), the driver is required to take active control.

The lane departure assist system function will be limited or does not work in the following conditions:

- The driver turns on the turn signal lights at the side across the line;
- The driver turns on the hazard warning light;
- The driver presses the accelerator pedal rapidly, makes emergency steering or presses the brake pedal hard;
- The lane line is too thin, damaged or fuzzy;
- At night or poor light;
- The kerbs are irregular or damaged;
- The vehicle is driving on the curve with a small curvature radius or on too narrow or too wide road;
- The vehicle has just entered the road section with lanes or has passed the road section without lane lines;
- The vehicle makes rapid lane change or lateral sway;
- The vehicle speed is less than 55 km/h, or the speed is too high;
- The anti-lock brake system (ABS) and the dynamic stability control system (SCS) are activated;
- The anti-lock brake system (ABS), dynamic stability control system (SCS), electric power steering system (EPS), etc. fail.

It is recommended to turn off the lane departure assist system in the following situations:

- Drive in sports style;
- Drive in bad weather;
- Drive on poor road section;
- Drive through road construction site.

Forward Collision Assist System

Forward Collision Assist System

The forward collision assist system switch is located on the central screen. The system can be turned on/off in the appropriate interface under "Intelligent Drive", and the relevant settings can be made.

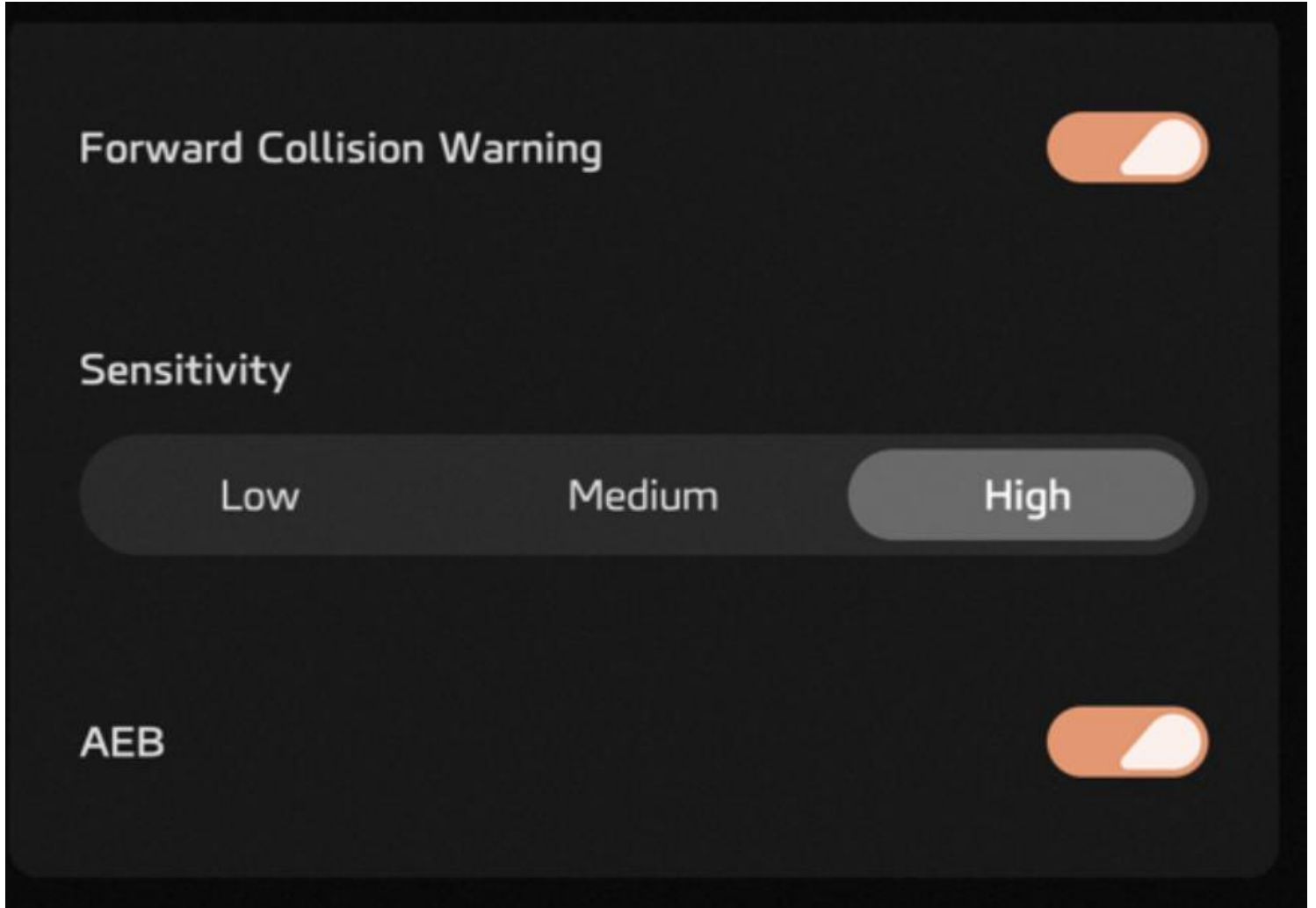

When the system detects a risk of collision between your vehicle and the vehicle ahead in the current lane or moving pedestrians, it will give an alarm to remind the driver to decelerate timely or automatically enable the brake system to slow down the vehicle to avoid collision or mitigate the damage of the collision. If the vehicle is braked to stop, it will keep stationary within a short time, then the control of the vehicle will be handed over to the driver.

Important Instructions for Using Forward Collision Assist System

Warning: The driver shall be responsible for the safety of the entire driving process, and must pay full attention and drive carefully even if the vehicle is equipped with forward collision assist system. As a driver assistance system, this system cannot prevent the accidents and avoid the collision in all situations. The driver should always observe the road conditions so as to avoid the accidents or emergency situations.

Warning: Emergency brake in the control state of forward collision assist system may cause injuries to the occupants, therefore, always drive with care and turn off the forward collision assist system when the vehicle is being towed with all occupants inside. If the system is enabled when the vehicle is being towed, adverse effects may be caused to your vehicle, the towing vehicle and the safety of the people around.

Warning: Never specially test the functions of forward collision assist system to avoid the occurrence of accidents.

The system will automatically slow down the vehicle only when the following conditions are met:

- The dynamic stability control system (SCS) and traction control system (TCS) are ON and failure-free;
- The vehicle is in Drive or Neutral gear;
- The airbags are not deployed.

Note: In some cases, the driver may not predict and does not want to apply the brake, but if the forward collision assist system is applying strong brake force, the driver can temporarily cancel the system by firmly depressing the accelerator pedal or turn the steering wheel if it is safe to do so.

The forward collision assist system function will be limited or does not work in the following conditions:

- There is oncoming traffic, the vehicle ahead drives across transversely or cuts in suddenly;
- The vehicle ahead does not follow the rules of driving (for example, driving across lanes) and parking (on the roads transversely);
- The vehicle ahead is not on the same lane of this vehicle or is partially blocked;
- The vehicle ahead is a non-standard motor vehicle (for example, a refitted vehicle);
- The vehicle ahead is a vehicle with high chassis.
- The vehicle ahead is a large vehicle and at a close distance (such as a tractor, a trailer, a towing vehicle, a mud-carrying vehicle and a sanitation truck);
- The vehicle ahead is some means of transportation rarely can be seen on the road (such as the ox cart, carriage or others);
- The vehicle ahead is a bicycle, motorbike or small wheeled object (such as suitcases, shopping carts or wheelchairs);
- The contour of the vehicle ahead is unclear due to the water sprayed by the wheels of the surrounding vehicles;
- The vehicle ahead does not turn on the tail lamps when driving at night or in the tunnel;
- The tail lamps of the vehicle ahead are all LED lamps or other home-made fairy lights;
- When driving on the boulevard, the road lamp flashes erratically;
- The pedestrian is not directly in front of the vehicle or not fully visible;
- The pedestrian does not stand upright or is a shorter child;
- A crowd of people or the pedestrian is in the tree shadow or in the dark;
- There is an animal ahead;
- There are foreign obstacles on the ground ahead (such as a roadblock, an isolation pile, an isolation strip, big rocks, other scattered objects, etc.);
- There are signs, guardrails, bridges, buildings, etc. ahead;
- The vehicle drives on a slope, the section coming on/off the bridge or curve;
- The vehicle is in Reverse gear;
- The vehicle is in braking or harsh acceleration state.

Break-down

Hazard Warning Device

Warning Triangle

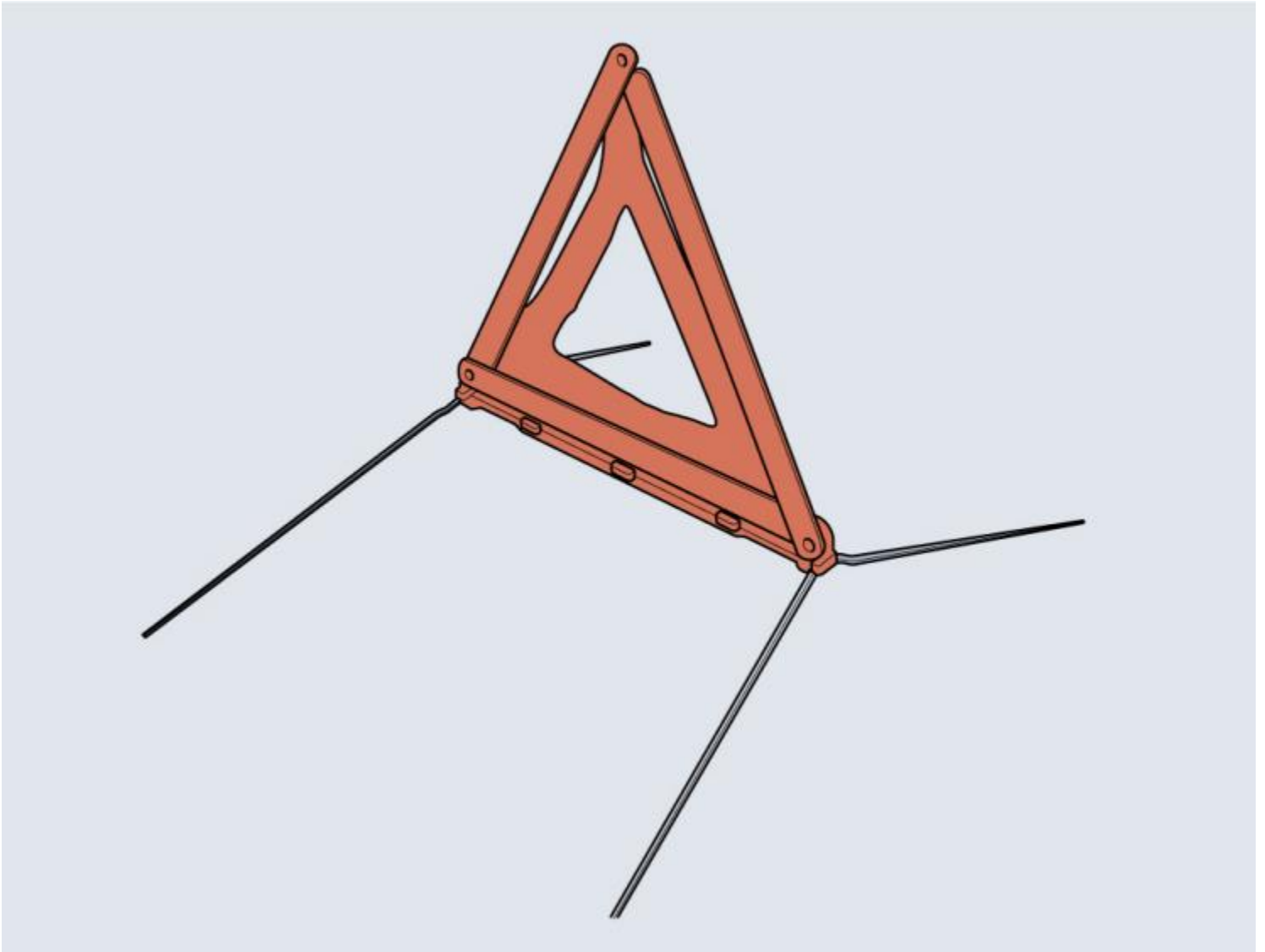

The warning triangle is placed in the trunk.

If you have to stop your vehicle on the roadside in an emergency, you must place a warning triangle approximately 50 to 150 metres behind the vehicle if possible, and press the hazard warning lamp button to warn other road users of your position.

Reflective Vest

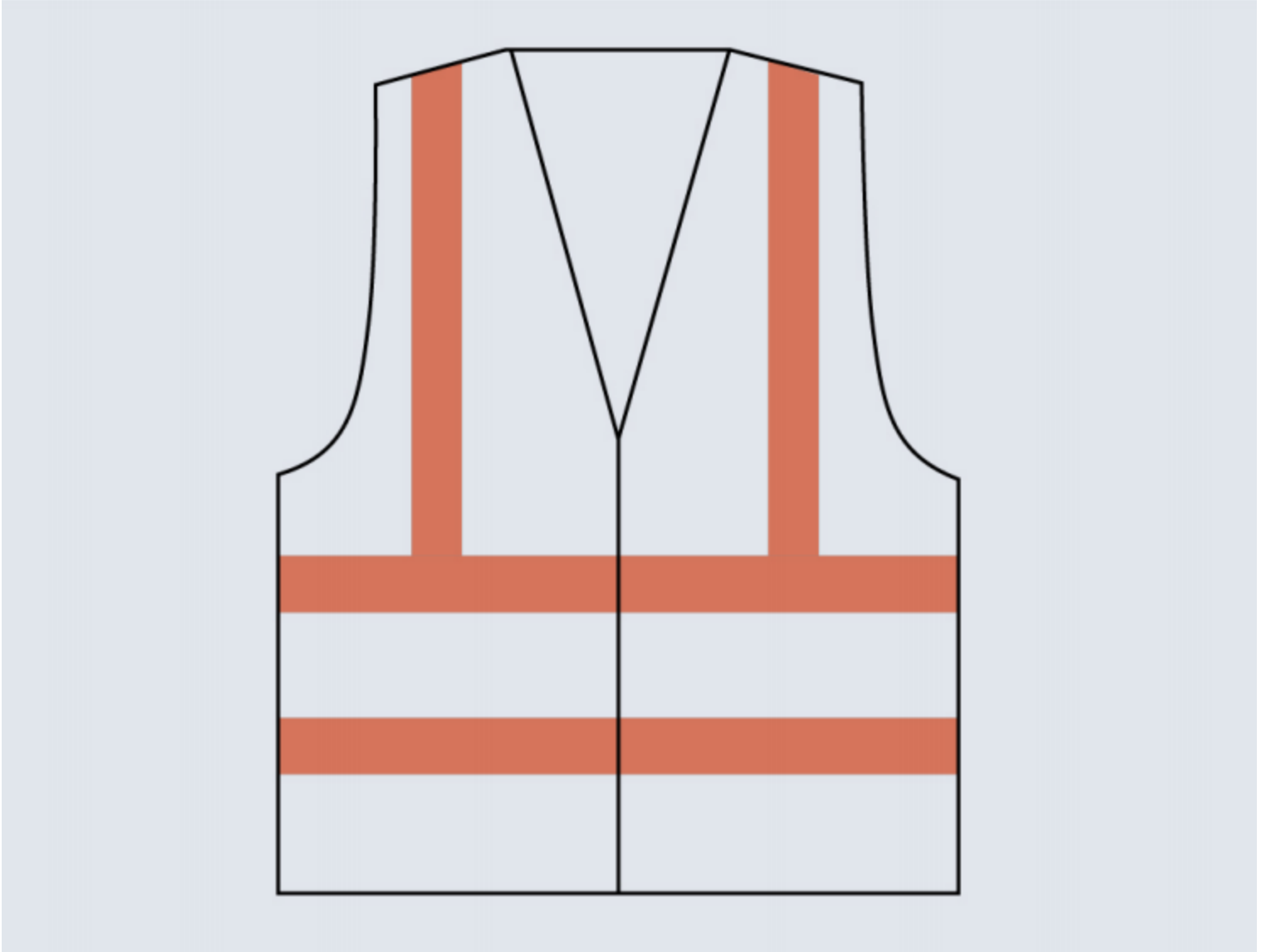

The reflective vest is placed in the centre console armrest box.

If you have to stop your vehicle on the roadside in an emergency and get out of for check, please take out the reflective vest from the centre console armrest box and wear it properly, then get out of the vehicle to check the details of the vehicle to ensure your safety.

Towing and Shipping

Towing hook

Warning: Do not tow the vehicle with all four wheels on the ground. Suspended towing or trailer may be used, and auxiliary wheels should be used to keep the wheels off the ground during suspended towing, otherwise the electric drive unit may be damaged. If pushing the vehicle is required in some cases, the speed shall be less than 5 km/h and the duration shall be less than 3 minutes.

Warning: When pushing or towing the vehicle with the towing hook, the driver side seat belt should be inserted into the buckle and maintained in this state, turn the shift knob to N and release the EPB, otherwise the vehicle may be damaged.

Warning: DO NOT use a twisted tow rope, otherwise the towing hook may be loosened.



Your car is equipped with 2 towing eyes (located at the front and the rear of the vehicle), which are used for fitting the towing hook in the trunk. To fit the towing hook, remove the small cover set into the bumper, first press one end of the small cover plate, open the small cover plate in the direction as shown after the other end is lifted, and then screw the towing hook via the small hole into the threaded hole in the bumper beam (as shown in the figure). Ensure the towing hook is fully tightened!

Note: The removed cover plate is connected to the bumper by a plastic strip.

In case your vehicle broke down or encountered an accident, you can use the towing hook to tow your vehicle, such as towing your vehicle onto the transporter. But they are not designed for towing other vehicles. It is recommended to tow the vehicle with a hard rod, and if it is not available, a soft rope may be used.

Suspended Towing

When suspending, auxiliary wheels should be used to keep the wheels off the ground, otherwise the electric drive unit and other components may be damaged due to the drive wheels on ground. When towing, the hazard warning lamp shall be turned on and no passengers shall be left in the vehicle being towed, otherwise the vehicle damage or personal injury may be caused.

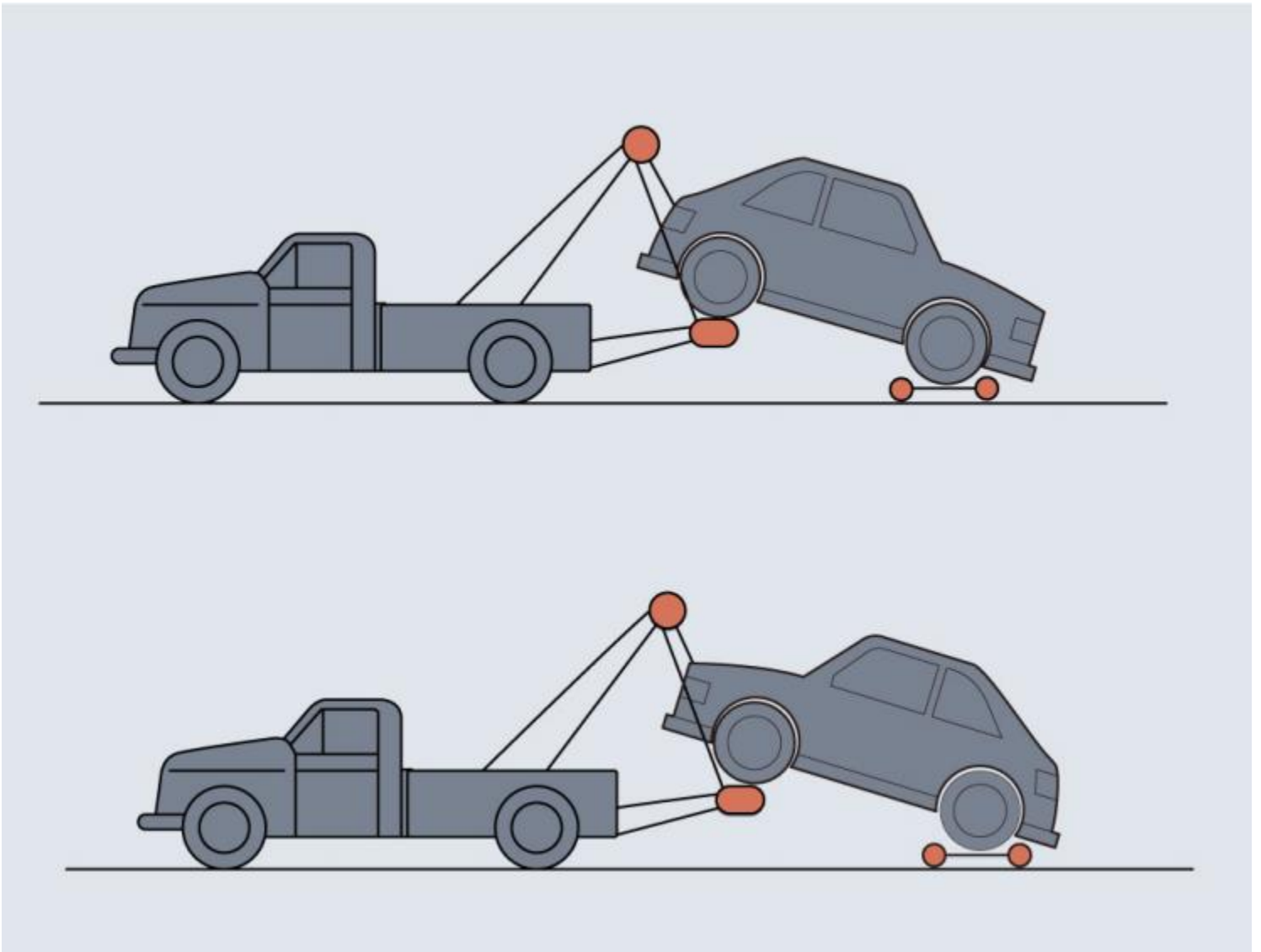

Vehicle Transport

If your vehicle needs to be transported, a special transporter is recommended. Secure the vehicle on the transporter as follows:

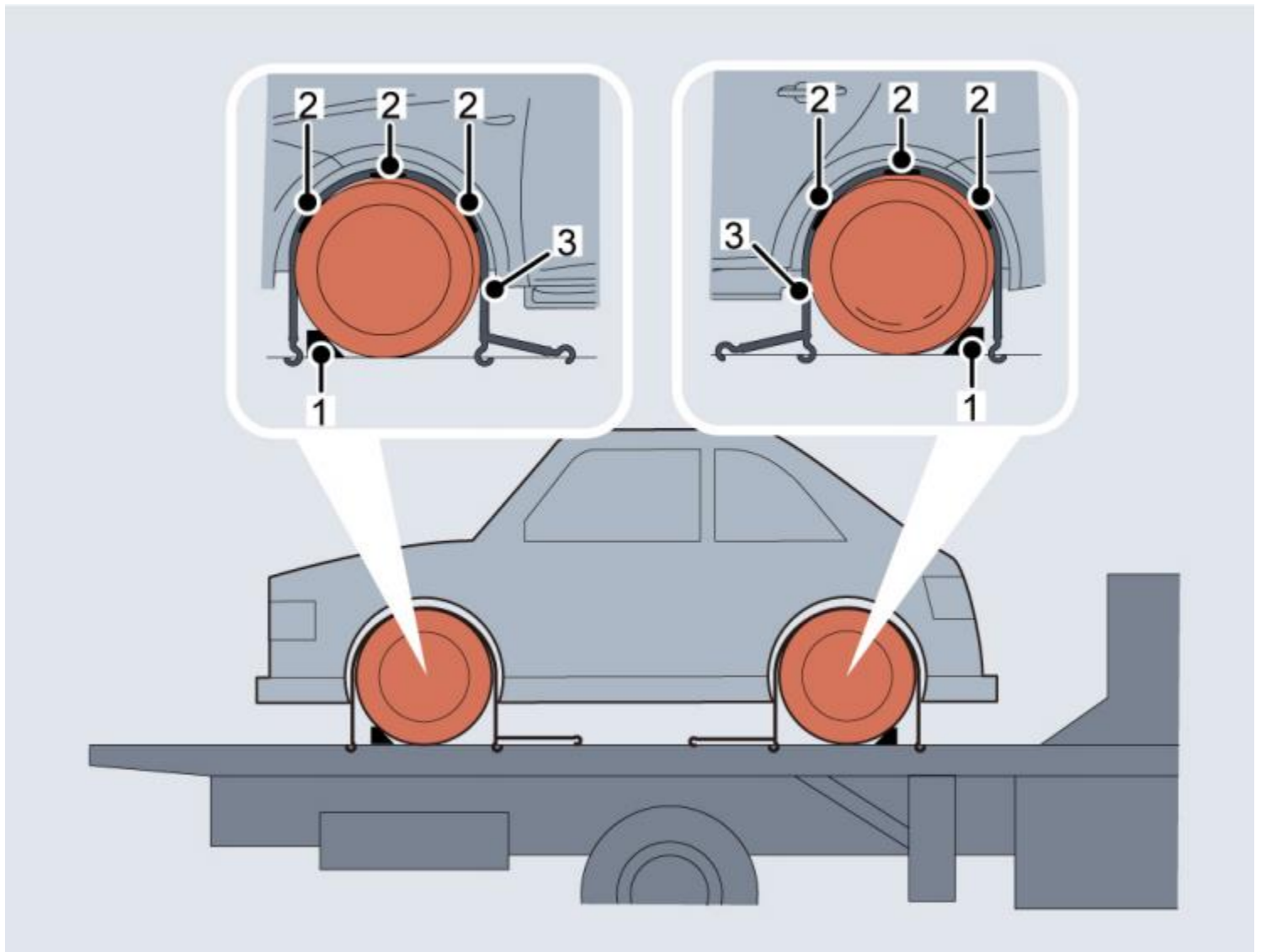

1. Before transporting the vehicle, make sure that the electronic parking brake system (EPB) is enabled. Refer to "Electronic Parking Brake System (EPB)" in "Braking and Parking" chapter for details.
2. Place the wheel chocks (1) as shown in the figure, and then position the anti-slip rubber blocks (2) around the wheel.
3. Fit the lashing straps (3) around the wheels and secure them on the trailer. Fasten the straps to secure the vehicle.

Fuse Replacement

Fuse

Fuses are simple circuit breakers which protect the car's electrical equipment by preventing the electrical circuits from being overloaded. A blown fuse indicates that the circuit under its protection fails and stops working.

If you suspect a fuse is faulty, you can take it out of the fuse box and inspect it to see if the wire in the fuse is blown.

It is recommended to carry spare fuses in the vehicle, which can be obtained from Authorised Repairer.

IMPORTANT

- NEVER attempt to repair a blown fuse. ALWAYS replace a fuse with one of the same rating, otherwise the fire may be caused due to electrical system damage or circuit overload.
- If the replaced fuse is blown immediately, please contact Authorised Repairer for service as soon as possible.

Fuse Box

The vehicle is equipped with 4 fuse boxes:

1. Front compartment fuse box (front left of the front compartment)
2. Passenger compartment fuse box (behind the driver side lower trim panel)
3. Battery fuse box (above the trunk battery)
4. Trunk fuse box (left side trim panel of the trunk)

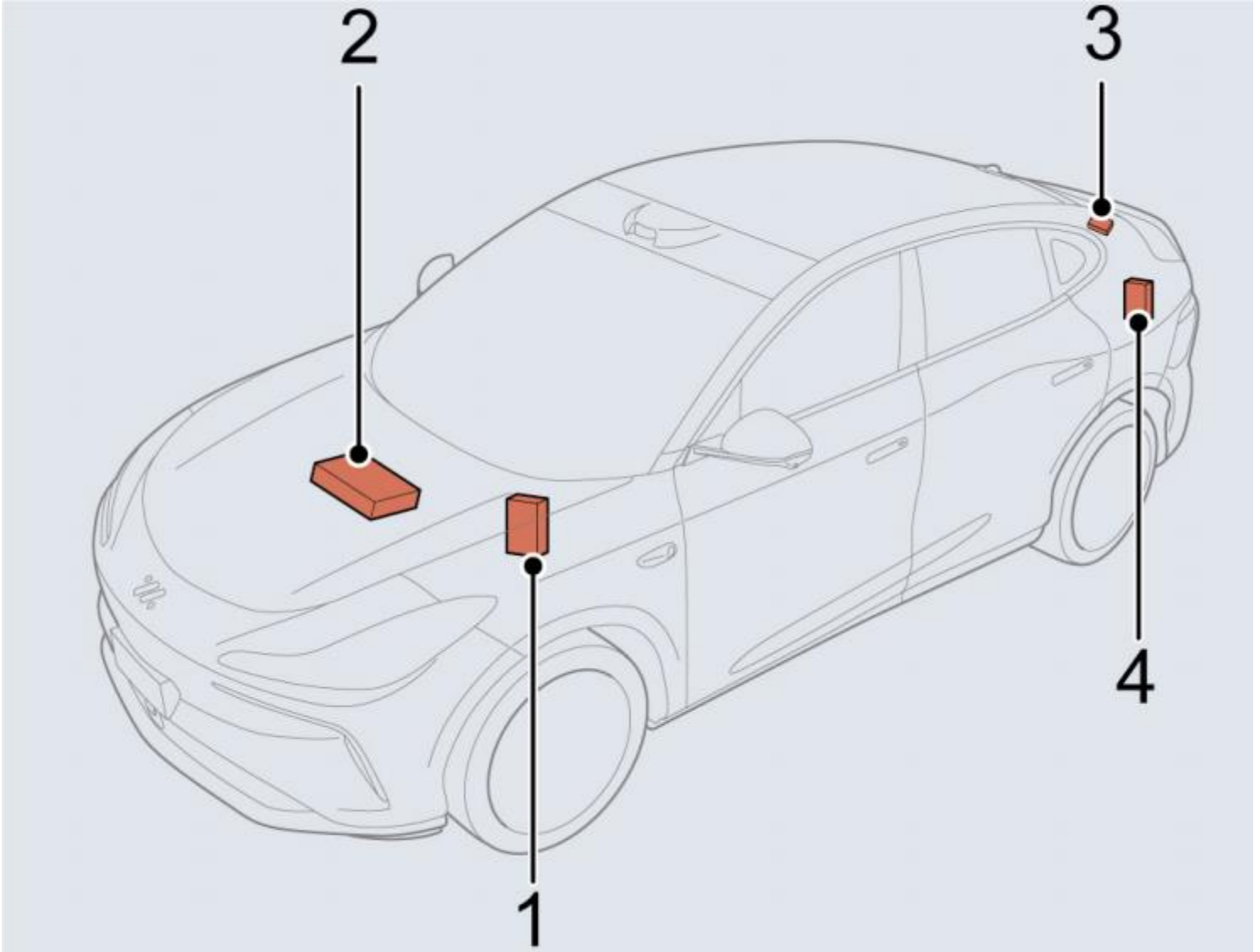

Front Compartment Fuse Box

Fuse Check or Replacement

1. Turn off the Start switch and all electrical appliances, and disconnect the negative battery cable.
2. Remove the front compartment trim cover, and open the upper cover of the fuse box.
3. Hold the fuse head with a fuse extractor, pull and remove the fuse. Check if any fuse is blown.
4. If a fuse is blown, replace it with another fuse of the same ampere value.

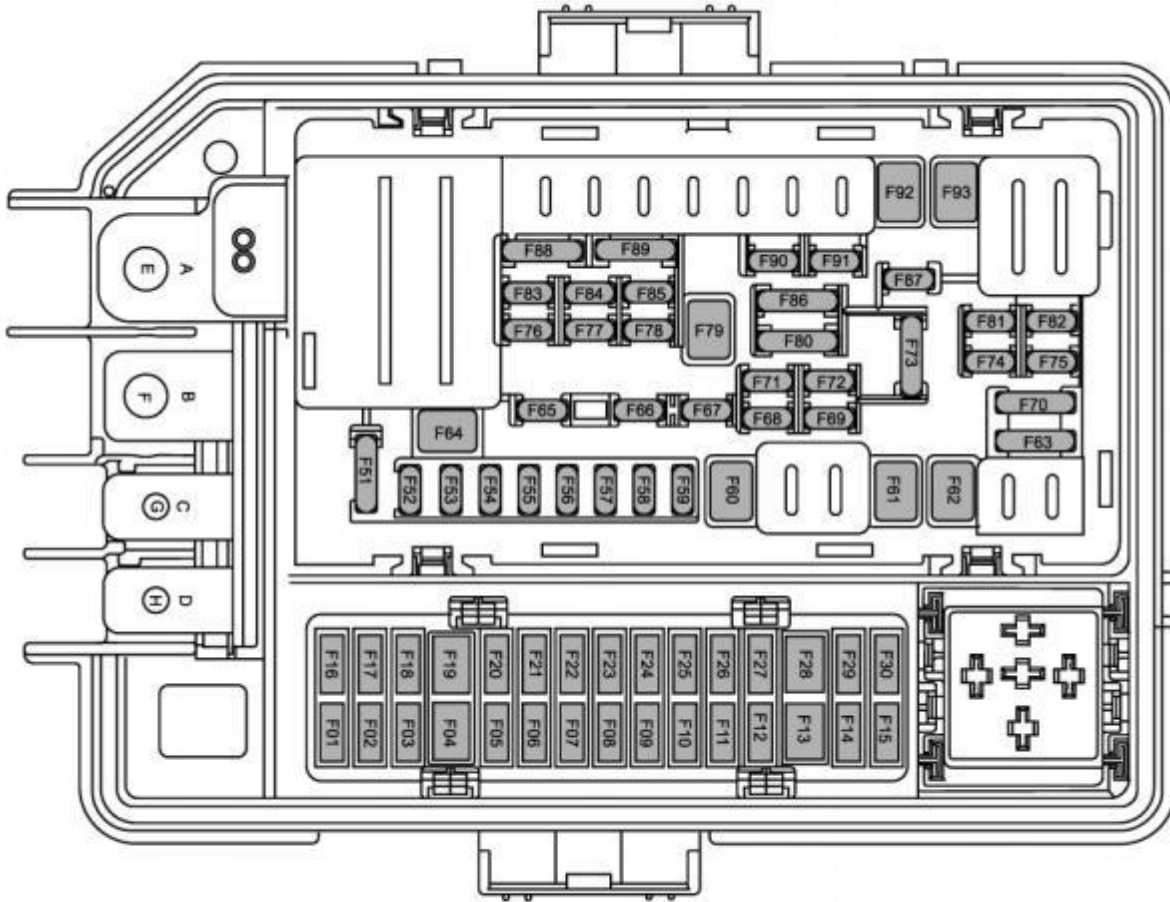

Mark No.	Specification	Function
A	-	-
B	-	-
C	100A	Electric power steering control module
D	-	-
E	-	-

F	-	-
G	60A	Cooling fan
H	60A	Integrated braking system (IBS)
F01	-	-
F02	-	-
F03	-	-
F04	-	-
F05	-	-
F06	5A	Electronic control water valve, multi-way valve of cooling system
F07	5A	Headlamp projection control module
F08	-	-
F09	15A	HVPTC water pump
F10	20A	Power electronic box cooling water pump
F11	-	-
F12	-	-
F13	-	-
F14	15A	High-voltage battery pack cooling water pump
F15	-	-
F16	-	-
F17	-	-
F18	-	-
F19	-	-
F20	-	-

F21	-	-
F22	-	-
F23	-	-
F24	-	-
F25	-	-
F26	5A	Parking assist control module
F27	-	-
F28	-	-
F29	-	-
F30	-	-
F31	-	-
F32	-	-
F33	-	-
F34	-	-
F35	-	-
F36	-	-
F37	-	-
F38	-	-
F39	-	-
F40	-	-
F41	-	-
F42	-	-
F43	-	-

F44	-	-
F45	-	-
F46	-	-
F47	-	-
F48	-	-
F49	-	-
F50	-	-
F51	15A	Horn relay, clock spring
F52	5A	Active intake grille
F53	20A	Front left Digital Light Processing assembly
F54	25A	Body control module
F55	30A	Body control module
F56	5A	Right front corner radar, left front corner radar, forward detection radar
F57	-	-
F58	15A	Body control module
F59	-	-
F60	-	-
F61	40A	Integrated braking system (IBS)
F62	30A	Right front door control unit, right rear door control unit
F63	5A	Sensing and diagnostic module, intelligent pilot device (IPD), intelligent cockpit, shifter control unit, body control module
F64	30A	Body control module
F65	-	-
F66	-	-

F67	15A	Front left Digital Light Processing assembly
F68	-	-
F69	25A	Body control module
F70	5A	Integrated braking system, electric power steering control module, high-voltage battery pack system, inertial measurement unit, intelligent motor control unit, secondary axle motor controller
F71	15A	Front right Digital Light Processing assembly
F72	20A	Front right Digital Light Processing assembly
F73	5A	Brake pedal switch
F74	-	-
F75	-	-
F76	-	-
F77	-	-
F78	-	-
F79	-	-
F80	10A	Secondary axle motor controller
F81	-	-
F82	-	-
F83	-	-
F84	-	-
F85	15A	Front windscreen washer relay, body control module
F86	15A	Automatic temperature control
F87	-	-
F88	5A	Electric air conditioning compressor, HV battery pack electric heater

F89	5A	Air quality sensor, driver seat backrest ventilation element, front passenger seat cushion ventilation element
F90	-	-
F91	25A	Body control module
F92	30A	Electronic wiper mechanism
F93	30A	Front left door control unit, rear left door control unit

Passenger Compartment Fuse Box

Fuse Check or Replacement

1. Turn off the Start switch and all electrical appliances, and disconnect the negative battery cable.
2. Remove the driver side trim panel.
3. Hold the fuse head with a fuse extractor, pull and remove the fuse. Check if any fuse is blown.
4. If a fuse is blown, replace it with another fuse of the same ampere value.

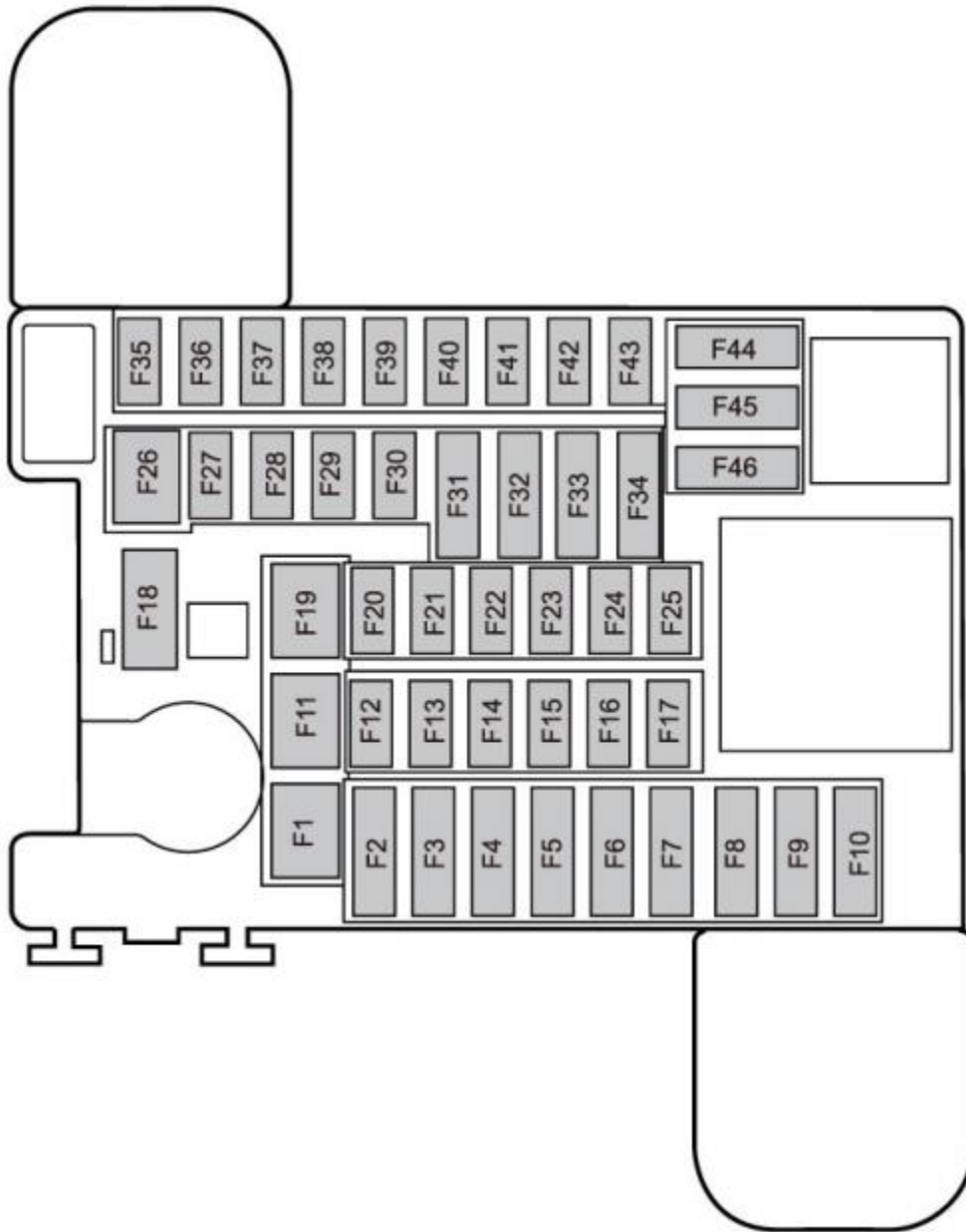

Mark No.	Specification	Function
F1	40A	Front blower
F2	5A	Seat adjustment switch, NFC entry mode, NFC enable module
F3	7.5A	Intelligent computation center
F4	15A	Clock spring
F5	7.5A	Ambient light, PM2.5&Incar integrated sensor
F6	7.5A	Door touch switch module, door opening touch switch, door handle
F7	5A	Shifter control unit
F8	7.5A	Electronic toll collection (ETC) module, rain/light/solar sensor
F9	-	-
F10	10A	Driver seat lumbar support massage module, front passenger seat lumbar support massage module
F11	30A	Driver seat control module
F12	-	-
F13		-
F14	10A	Sensing and diagnostic module
F15		-
F16	10A	USB hub
F17	15A	Driver screen
F18	-	-
F19	30A	Front passenger seat control module
F20	10A	Data link connector (DLC)

F21	15A	Central screen, front passenger screen
F22	-	-
F23	-	-
F24	20A	Intelligent cockpit
F25	15A	-
F26	-	-
F27	-	-
F28	-	-
F29	10A	Screen lift control module
F30	-	-
F31	7.5A	Overhead console module, air vent control module
F32	7.5A	Bluetooth passive entry and passive start control module, intelligent antenna module, clock spring
F33	-	-
F34	-	-
F35	-	-
F36	-	-
F37	-	-
F38	-	-
F39	-	-
F40	-	-
F41	-	-
F42	-	-
F43	-	-

F44	15A	Front console power socket, rear power socket
F45	-	-
F46	10A	Centre console rear USB charging module

Trunk Fuse Box

Fuse Check or Replacement

1. Turn off the Start switch and all electrical appliances, and disconnect the negative battery cable.
2. Remove the driver side trim panel.
3. Hold the fuse head with a fuse extractor, pull and remove the fuse. Check if any fuse is blown.
4. If a fuse is blown, replace it with another fuse of the same ampere value.

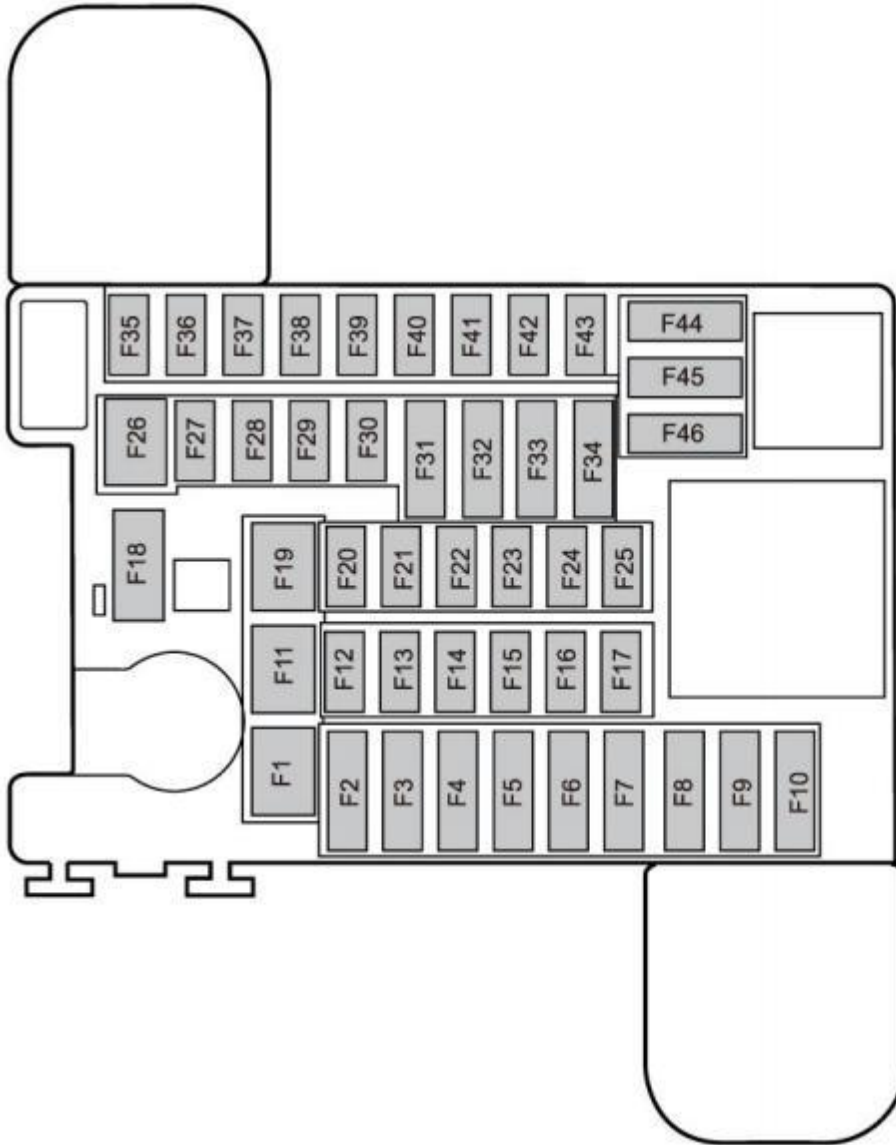

Mark No.	Specification	Function
F01	30A	Automatic temperature control, rear windscreen heating element
F02	5A	Rearward corner radar, charging port door
F03	15A	Tail lamp assembly
F04	5A	Power tailgate control unit
F05	10A	Front LIDAR
F06	5A	Combined charging unit (CCU), electric parking motor control unit
F07	-	-
F08	-	-
F09	-	-
F10	10A	Intelligent motor control unit
F11	-	-
F12	25A	Power amplifier
F13	20A	Electric parking motor control unit
F14	-	-
F15	25A	Intelligent pilot device
F16	20A	Manual service disconnect
F17	10A	-
F18	25A	Electronic oil pump controller
F19	-	-
F20	25A	Power tailgate control unit
F21	20A	Tail lamp assembly
F22	10A	High-voltage power distribution unit

F23	25A	Power amplifier
F24	-	-
F25	25A	Power tailgate control unit
F26	-	-
F27	-	-
F28	-	-
F29	-	-
F30	-	-
F31	-	-
F32	-	-
F33	-	-
F34	-	-
F35	10A	Rearview mirrors
F36	-	-
F37	-	-
F38	-	-
F39	-	-
F40	-	-
F41	-	-
F42	-	-
F43	-	-
F44	-	-
F45	-	-

F46	-	-
-----	---	---

Battery Fuse Box

Fuse Check or Replacement

1. Turn off the Start switch and all electrical appliances, and disconnect the negative battery cable.
2. Remove the driver side trim panel.
3. Hold the fuse head with a fuse extractor, pull and remove the fuse. Check if any fuse is blown.
4. If a fuse is blown, replace it with another fuse of the same ampere value.

	Specification	Function
Mark No.		
F1	100A	Trunk fuse box
F2	100A	Passenger compartment fuse box
F3	150A	Front compartment fuse box
F4	300A	High voltage DC-DC converter

Emergency Rescue

Identifications and Signs





Appearance Identification Information



This model can be identified as an electric vehicle (without exhaust) with the appearance identification.

Safety Signs

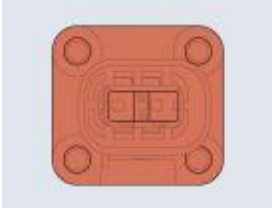
Note: Please always follow the safety requirements on the warning label of the high-voltage system. Not all high-voltage components are labeled. Complete insulating protective equipment shall be always worn during rescue. High voltage is dangerous. Please do not touch orange components or components with high-voltage warning label without authorization. Please note the following examples of safety signs.

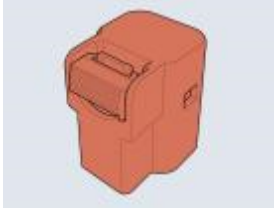
High-voltage Sign	High-voltage Harness	High-voltage Connector	High-voltage Label	Manual Service Disconnect
				
<p>High-voltage warning sign, indicating that the corresponding component has high-voltage power</p>	<p>High-voltage harness is orange, which is the carrier for the vehicle to transmit high-voltage power</p>	<p>High-voltage connector is orange, which connects the high-voltage component and high-voltage harness of the vehicle</p>	<p>High-voltage label is located on the high-voltage component. Please follow the safety requirements on the label</p>	<p>Manual service disconnect is orange, which should be disconnected before working on the high-voltage system</p>

Note: Depending on the market area and date of manufacture of the vehicle, the label may be changed or translated into other languages.

High-voltage System Key Components and Layout

High-voltage System Components

High-voltage System Components - 800V

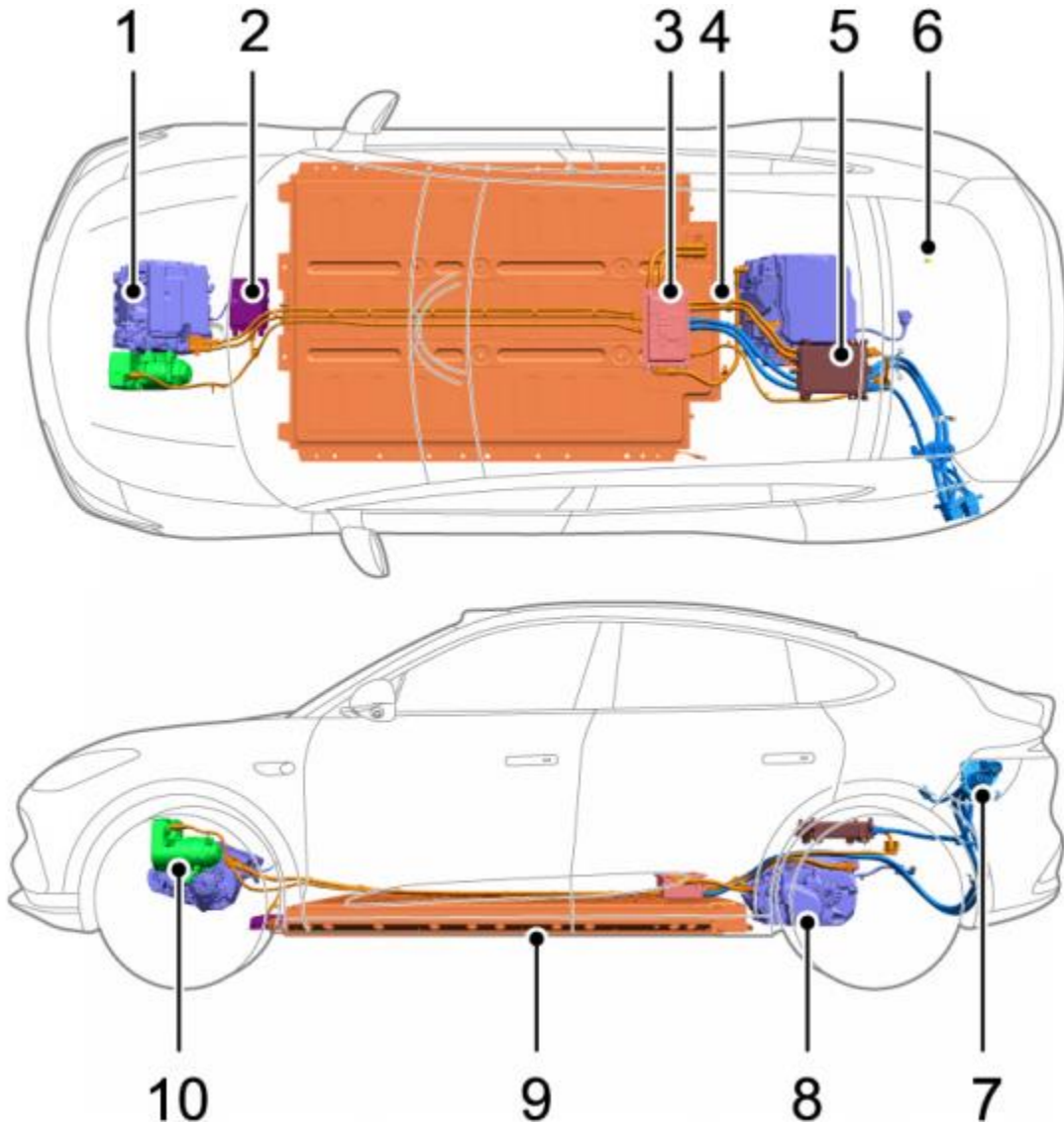

1. Front Electric Drive Unit*
2. Battery Heater
3. High-voltage Power Distribution Unit
4. High-voltage Harness
5. Combined Charging Unit
6. Manual Service Disconnect (MSD)
8. Rear Electric Drive Unit
9. High-voltage Battery Pack
10. Electric A/C Compressor

High-voltage System Components - 400V

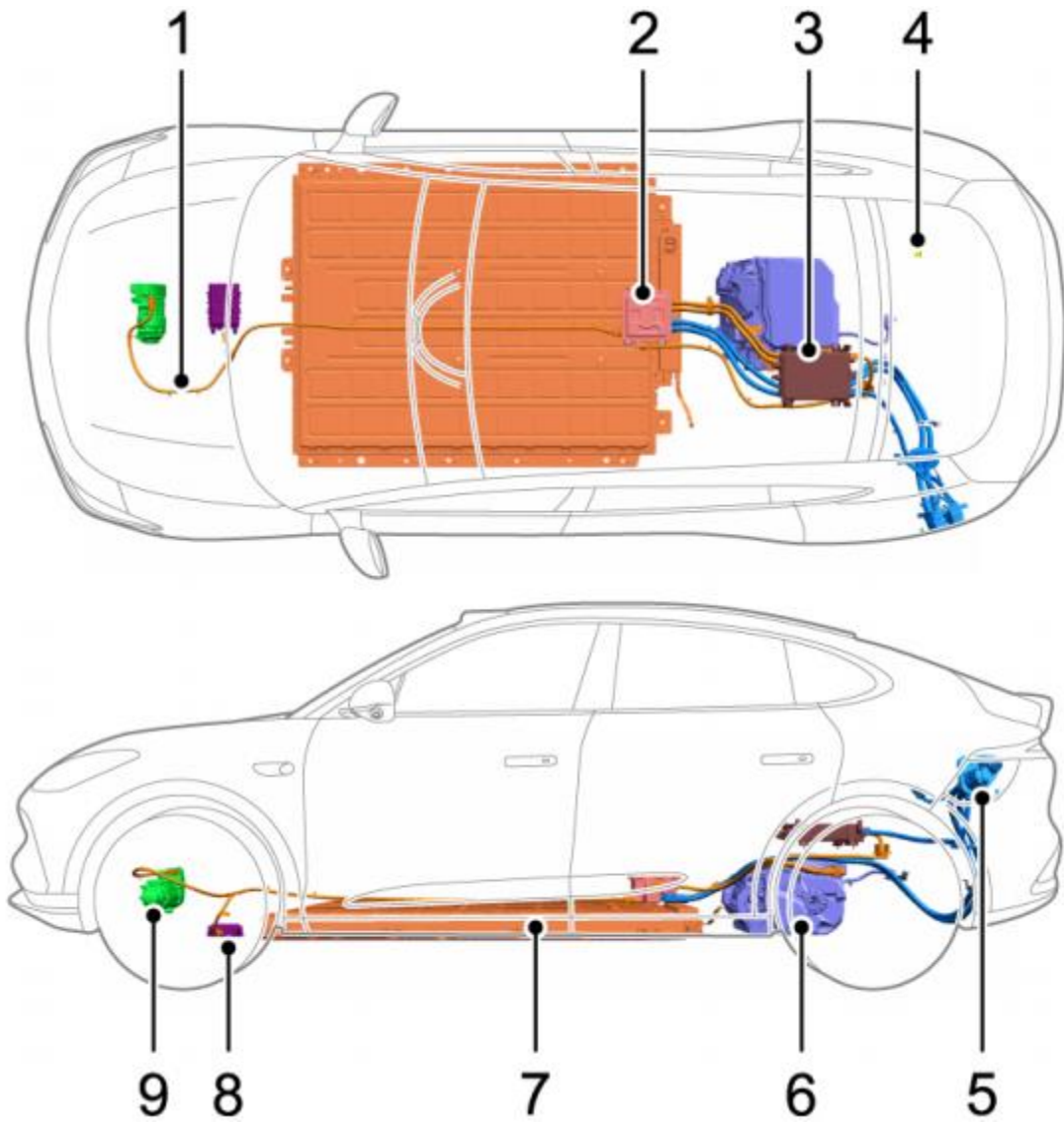

1. High-voltage Harness
2. High-voltage Power Distribution Unit
3. Combined Charging Unit
4. Manual Service Disconnect (MSD)
5. Charging Port
6. Rear Electric Drive Unit
7. High-voltage Battery Pack
8. Battery Heater
9. Electric A/C Compressor



Emergency Rescue

Safety Instructions for Emergency Rescue

- Please always observe the high-voltage safety precautions during rescue. The personnel safety shall be ensured preferentially in any case.
- Vehicle components with high-voltage warning label and orange harnesses are high-voltage components. Please always follow the safety requirements on the warning label of the high-voltage system.
- Work on high-voltage components shall be performed by qualified personnel, and the operators shall always wear complete insulating protective equipment and use insulating tools.
- When working on high-voltage components, the high voltage must be disconnected by strictly following the operation instructions of "High Voltage Disconnection" in this Handbook to ensure safety before proceeding.
- Never damage the high-voltage battery pack when lifting the vehicle from below. Please take extra care to ensure that the floor is not damaged when using rescue tools.
- Regardless of the operations, care should always be taken with all high-voltage components, and cutting, squeezing or touching high-voltage components may cause severe injury or death.

Protective equipment

Work on high-voltage components shall be performed by qualified personnel, and the operators shall be provided with the corresponding insulating protective equipment and use insulating tools.

Insulating Protective Equipment and Insulating Tools	Illustration
Insulating gloves, withstand voltage 1kV	
Insulating shoes, withstand voltage 18kV	

Insulating tools, withstand voltage 1kV



Insulating pad, withstand voltage 10kV



High Voltage Disconnection

When the power system can be turned off normally, the rescuers can disconnect the high-voltage output by first turning off the power system, then disconnecting the negative cable of 12V low-voltage battery, and then the manual service disconnect.

In an emergency, the high-voltage output can be disconnected by disconnecting the negative cable of 12V low-voltage battery and then the manual service disconnect.

Disconnection of 12V low-voltage battery

1. Open the trunk and remove the trunk carpet and storage box.
2. Disconnect or cut off the negative cable of 12V low-voltage battery.

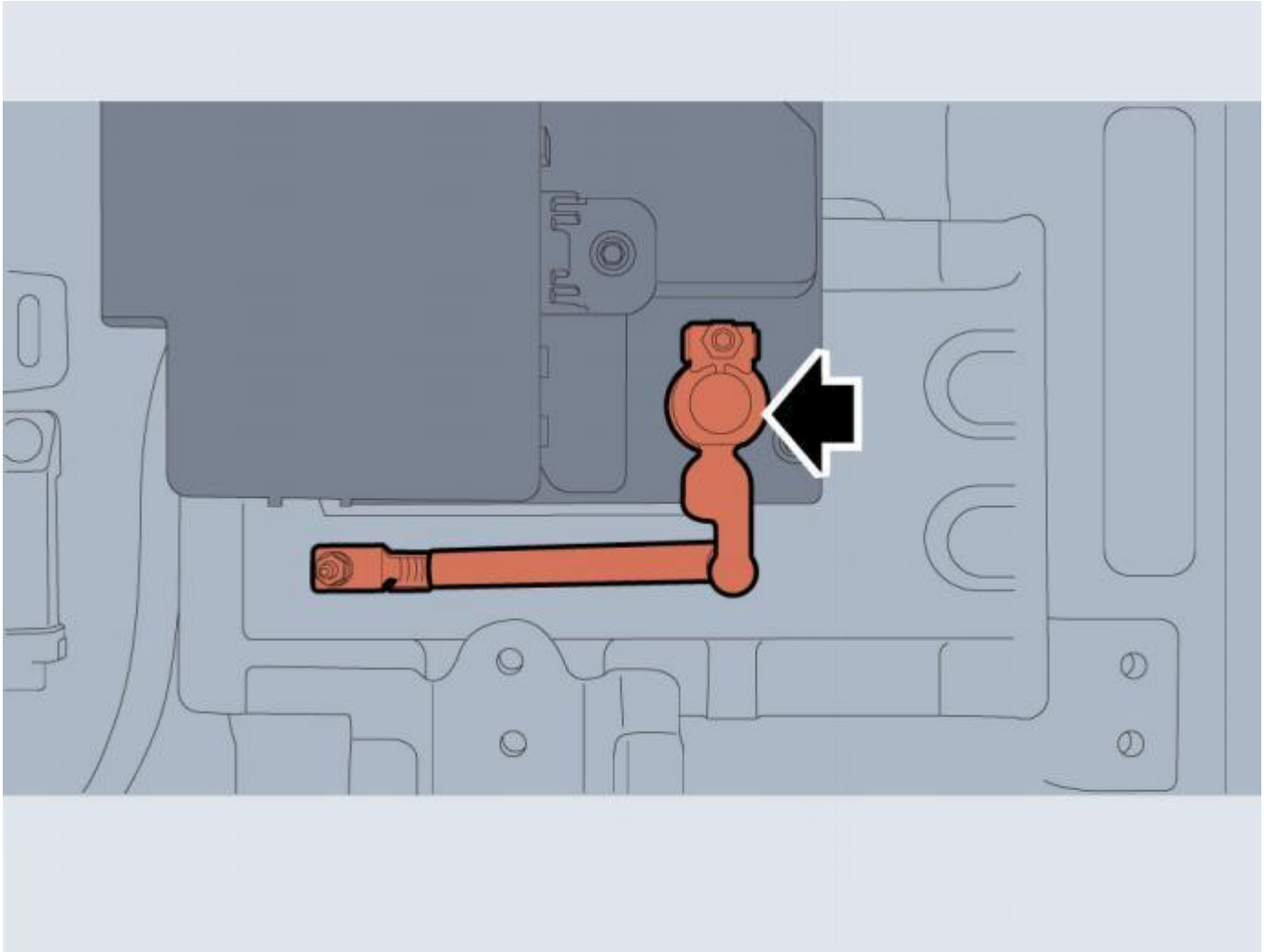

Note: After turning off the power system, the high-voltage circuit can be operated only after waiting for at least 1 minute.

Disconnection of manual service disconnect

When disconnecting the high voltage, the operators should wear complete insulating protective equipment and use special insulating tools:

1. Open the trunk and remove the trunk carpet and storage box.
2. Remove the manual service disconnect.

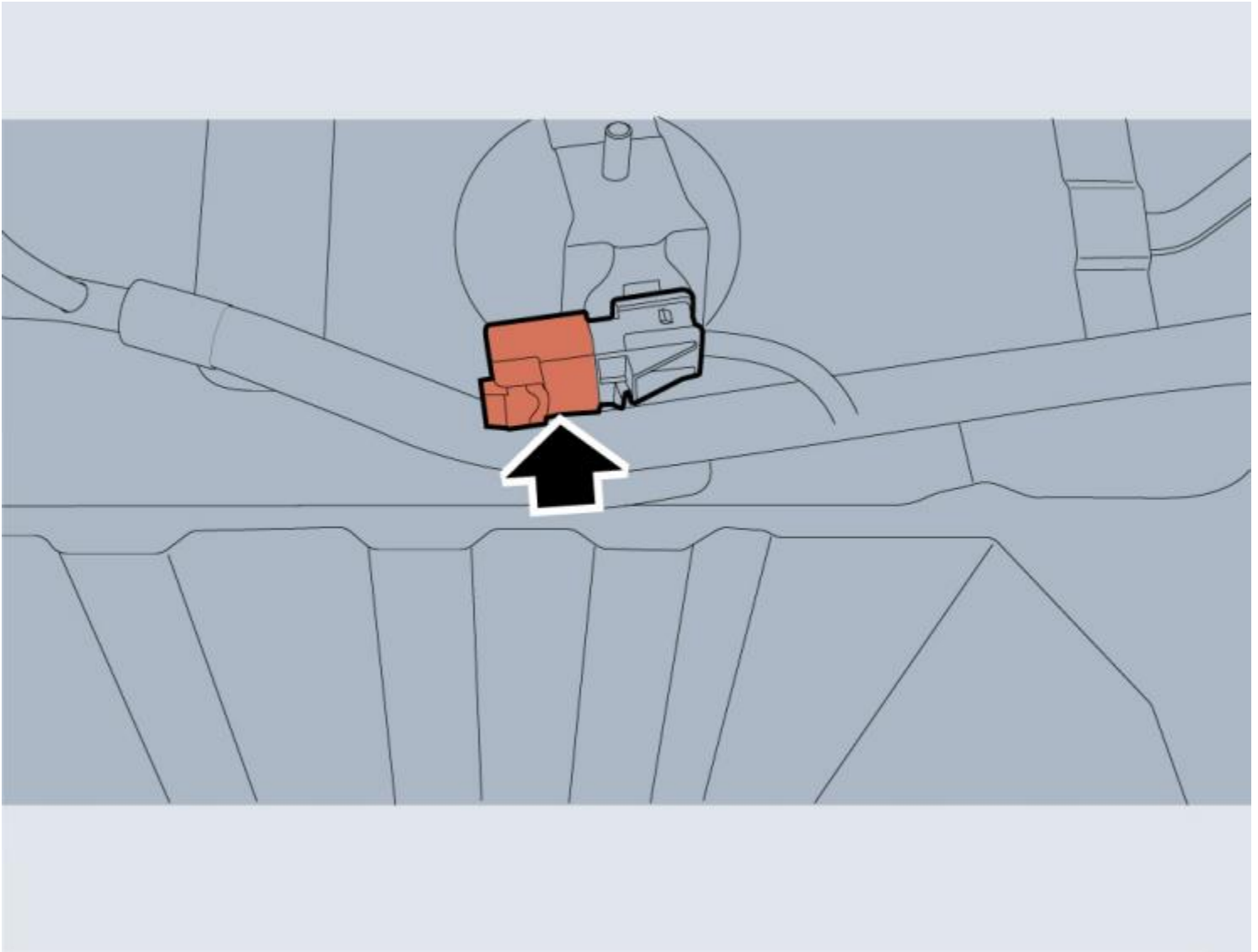

Note: When the manual service disconnect is removed, measures shall be taken to prevent foreign objects from entering the manual service disconnect base.

IMPORTANT

To disassemble the components of high-voltage system, special equipment (voltmeter, etc.) should be used to confirm whether the high voltage is within the safety range (the voltage is not greater than 30 V AC (rms) and 60 V DC) before the corresponding operation.

Fire

Note: During rescue in fire, please always wear complete personal protective equipment, including self-contained breathing apparatus (SCBA) .

During rescue of a vehicle in fire, the rescuers should wear complete insulating protective equipment and use special insulating tools:

- The driver, passengers and irrelevant personnel shall move away from the vehicle immediately;
- Damaged metal live conductors of high-voltage components shall not be touched during rescue to prevent possible injuries due to electric shock;
- When thoroughly checking the fire, do not touch any high-voltage components and always use insulating tools for disposal. Disconnect the high-voltage output immediately if the conditions permit;
- If a small fire occurs and the flame does not spread to the high-voltage battery pack, carbon dioxide or ABC dry powder extinguishers may be used to extinguish the fire;
- If the high-voltage battery pack catches fire, a large amount of water may be used to continuously spray it to reduce its temperature. (If no one is trapped and the conditions do not permit rescue, the rescuers may allow it to burn out. Meanwhile, it shall be ensured that the fire does not spread and the inhalation of toxic substances in the smoke shall be avoided.)
- Burning or heated high-voltage battery releases toxic gases. The emergency personnel shall always use complete personal protective equipment (including SCBA) to protect themselves and take appropriate measures to direct smoke and gases to protect surrounding people from the accident.
- The battery contains many chemicals, with a risk of re-burning. Thermal imagers, thermometers and other devices shall be used in the handling process to monitor the battery temperature in real time. Once sharp rise of internal battery temperature or smoke release is found, the operation shall be stopped immediately, and spray guns shall be used to extinguish the fire and cool down until the thermal accident of high-voltage battery pack is under control.
- After the fire is completely extinguished, the accident vehicle should be transferred to a safe place for isolation immediately. When transferring the vehicle, it cannot be directly towed and should be transported by a rescue vehicle.
- If the high-voltage battery pack and high-voltage components are damaged, a small amount of liquid may leak, such as lithium battery electrolyte and coolant. Do not touch it directly, clean it up timely, and prevent it from entering the sewer system or other waters.
- After rescue, the accident vehicle and high-voltage battery pack shall be handled properly, and the Authorised Repairer should be contacted timely for service and disposal.

Fire Extinguisher

Fire extinguishers should be purchased by yourself and replaced periodically. Carbon dioxide extinguisher or ABC dry powder extinguisher is recommended.



When the vehicle catches fire and the fire is small, an extinguisher can be used to extinguish it (refer to the instructions for use of fire extinguisher).

Note: When using a fire extinguisher, direct skin contact should be avoided to prevent frostbite.

Wading

Like other vehicles, wading will not cause a greater risk to your vehicle. Insulating protective equipment shall be worn when handling any water-logged vehicle.

- The driver, passengers and irrelevant personnel shall move away from the vehicle immediately;
- Damaged metal live conductors of high-voltage components shall not be touched during rescue to prevent possible injuries due to electric shock;
- If there is no hiss or foam from the high-voltage battery pack of the water-logged vehicle, it can be salvaged by a professional agency;
- After salvaging, the high voltage of the vehicle shall be disconnected timely, and the vehicle shall be placed in an open area for isolation;
- When transferring the vehicle, it cannot be directly towed and shall be transported by a rescue vehicle;
- After rescue, the accident vehicle and high-voltage battery pack shall be handled properly, and the Authorised Repairer should be contacted timely for service and disposal.



Cutting

Warning: Regardless of the disable procedure used, care should always be taken with all high-voltage components to avoid possible power-on risks, and cutting, squeezing or touching high-voltage components may cause severe injury or death.

When cutting a vehicle, please use proper tools (such as hydraulic cutter) and always wear proper personal protective equipment, otherwise severe injury or death may be caused.

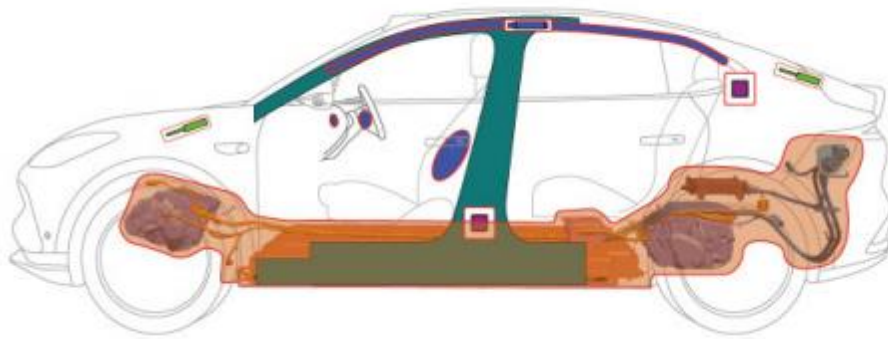
- Components such as high-voltage system, gas spring, supplementary restraint system (SRS) and high-pressure gas cylinder are defined as non-cuttable areas (red wireframe area in the figure). Do not cut or squeeze these areas, otherwise severe injury or death may be caused. High-voltage components can be cut only after the high voltage is disconnected, except for high-voltage battery pack.
- To protect the drivers and passengers, some areas of the body are made of ultra-high strength steel, so that these areas (blue areas in the figure) shall be dismantled and expanded using the appropriate tools during the rescue.



-  Ultra-high strength area
-  Non-cuttable area

Lifting

Warning: Never damage the high-voltage battery pack when lifting the vehicle from below. Please take extra care to ensure that the floor is not damaged when using rescue tools.

The high-voltage battery pack is located on the underside of the vehicle. When lifting or stabilizing the vehicle, only use the designated lifting area (as shown in green in the figure), and ensure that the high-voltage battery pack (orange area in the figure) or other high-voltage components are not contacted.

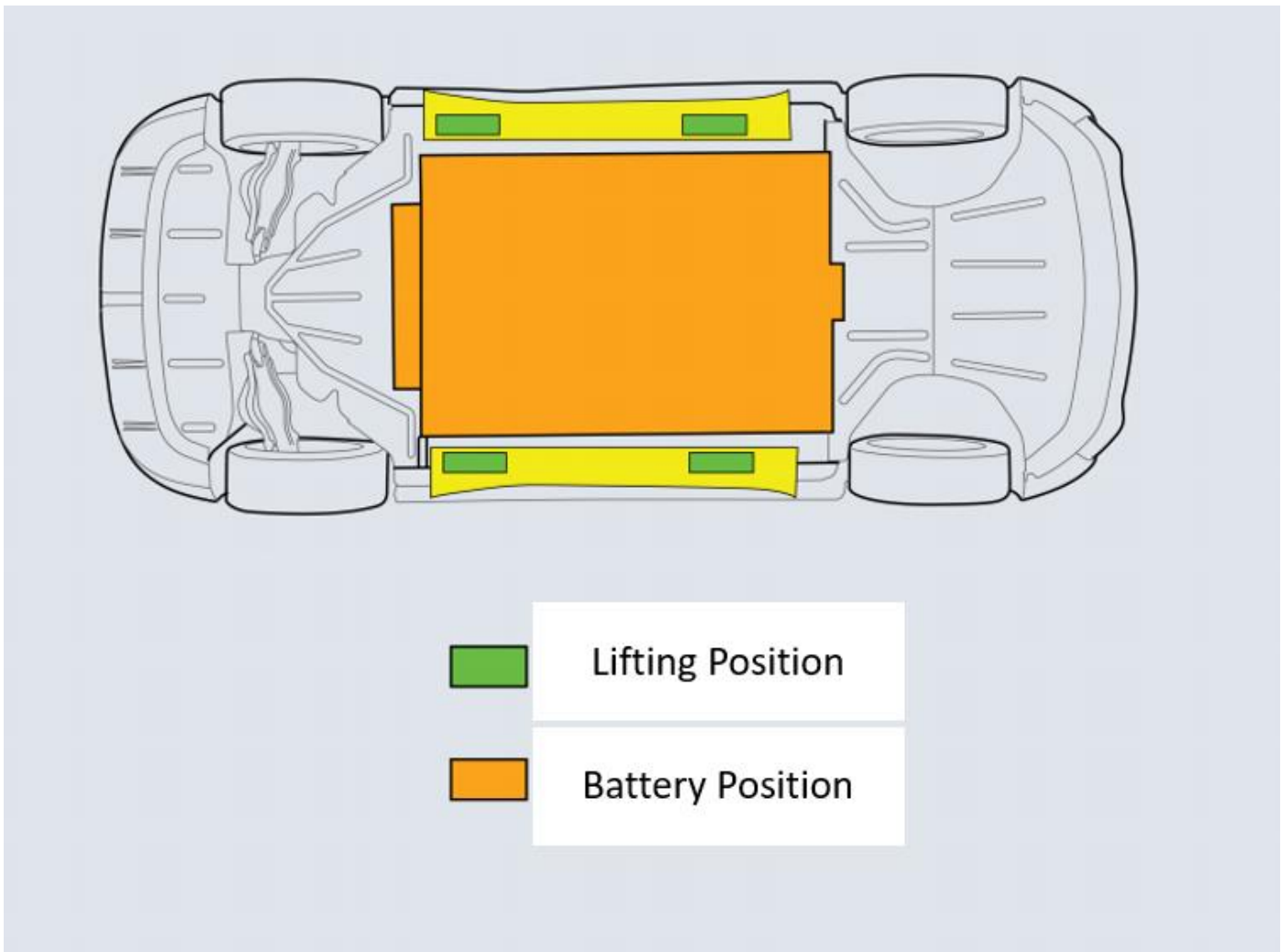

Vehicles Evacuated from the Scene after the Accident

After an accident occurs, the measures to evacuate from the scene are as shown below. When transporting the vehicle, place wheel chocks (1) as shown in the figure, and then position the anti-slip rubber blocks (2) around the wheel. Meanwhile, fit the lashing straps (3) around the wheels and secure them on the trailer. Fasten the straps to secure the vehicle.

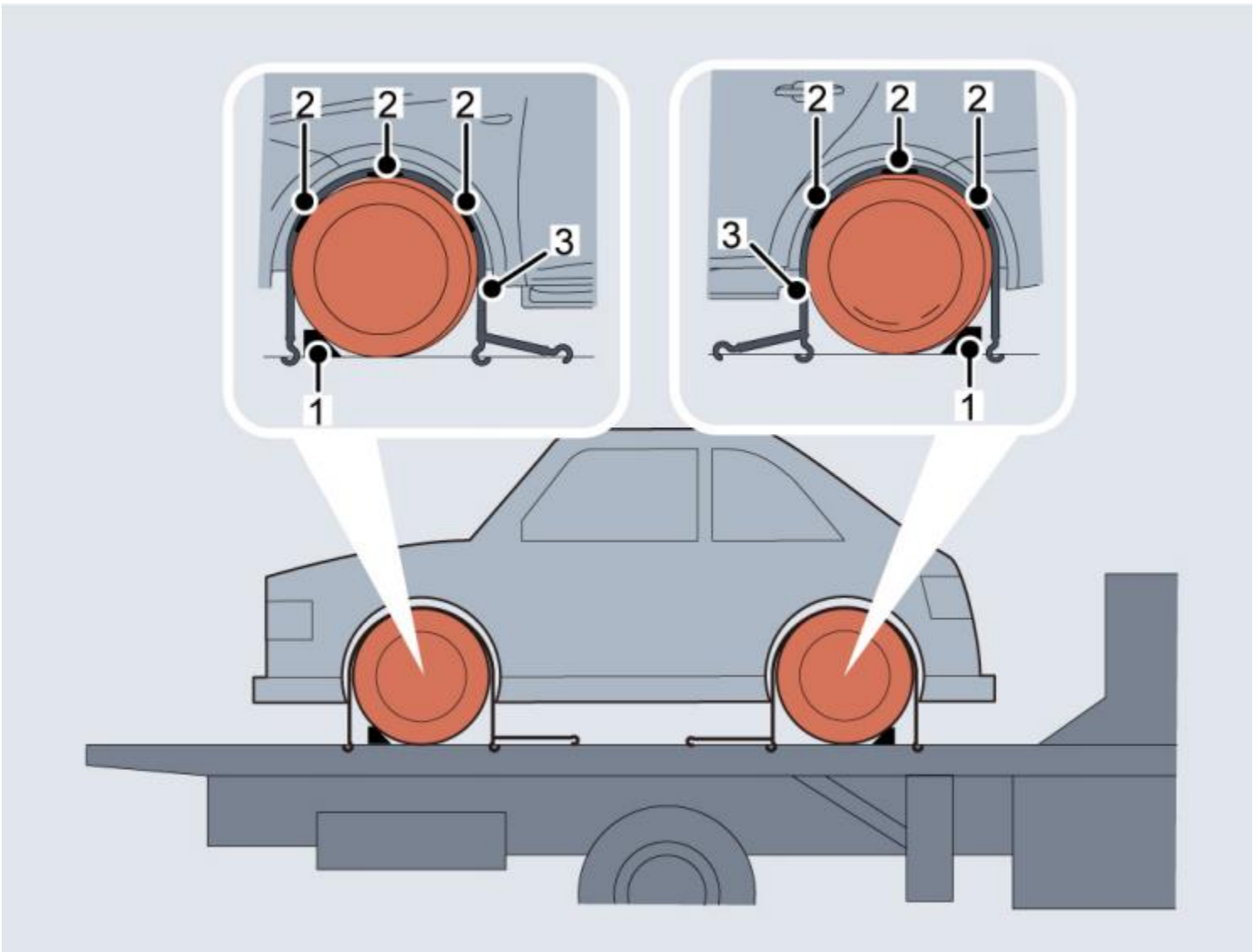

In case your vehicle broke down or encountered an accident, you can use the towing hook to tow your vehicle, such as towing your vehicle onto the transporter. But they are not designed for towing other vehicles. It is recommended to tow the vehicle with a hard rod, and if it is not available, a soft rope may be used.

Suspended towing is the best method for recovering a vehicle that needs to be towed. The drive wheels should be suspended above the ground, or the transmission may be damaged. Turn on the hazard warning lamp, with no passenger left in the vehicle.

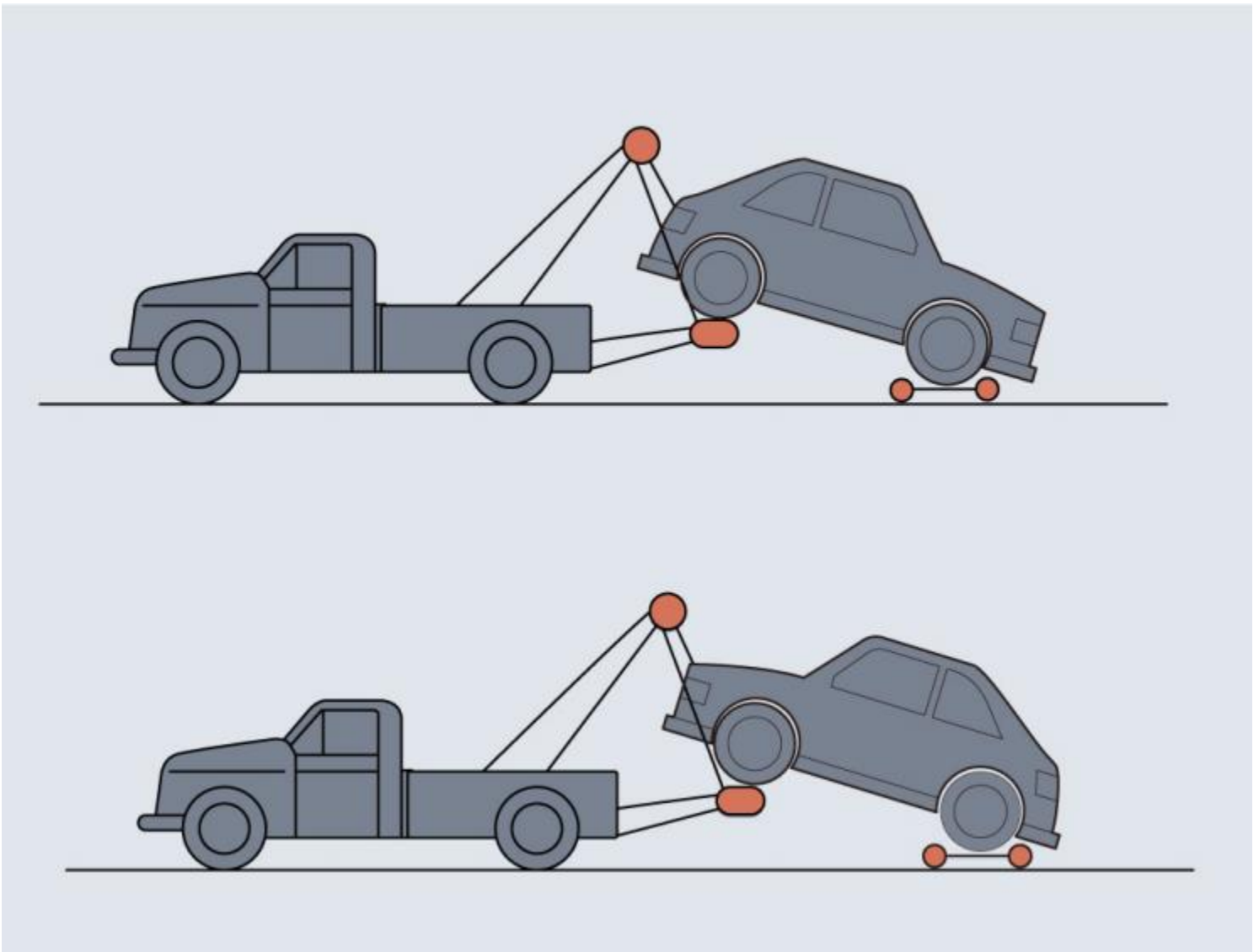

IMPORTANT

- Only when there is no safety risk to the vehicle can it be towed away from the site. If the vehicle battery pack is deformed, leaking or smoking, the safety risk should be tackled first.
- Before transporting the vehicle, ensure that the parking system is enabled.
- Before towing the vehicle, turn on the hazard warning lamp, and close and lock the doors.
- When towing the vehicle, DO NOT start off suddenly with a large acceleration or speed up suddenly to avoid damage to the vehicle.
- When towing or transporting the vehicle, any passenger shall not be left in the vehicle.

Parking Operation

The vehicle can be parked and the power system be turned off as follows when normal pullover is allowed.

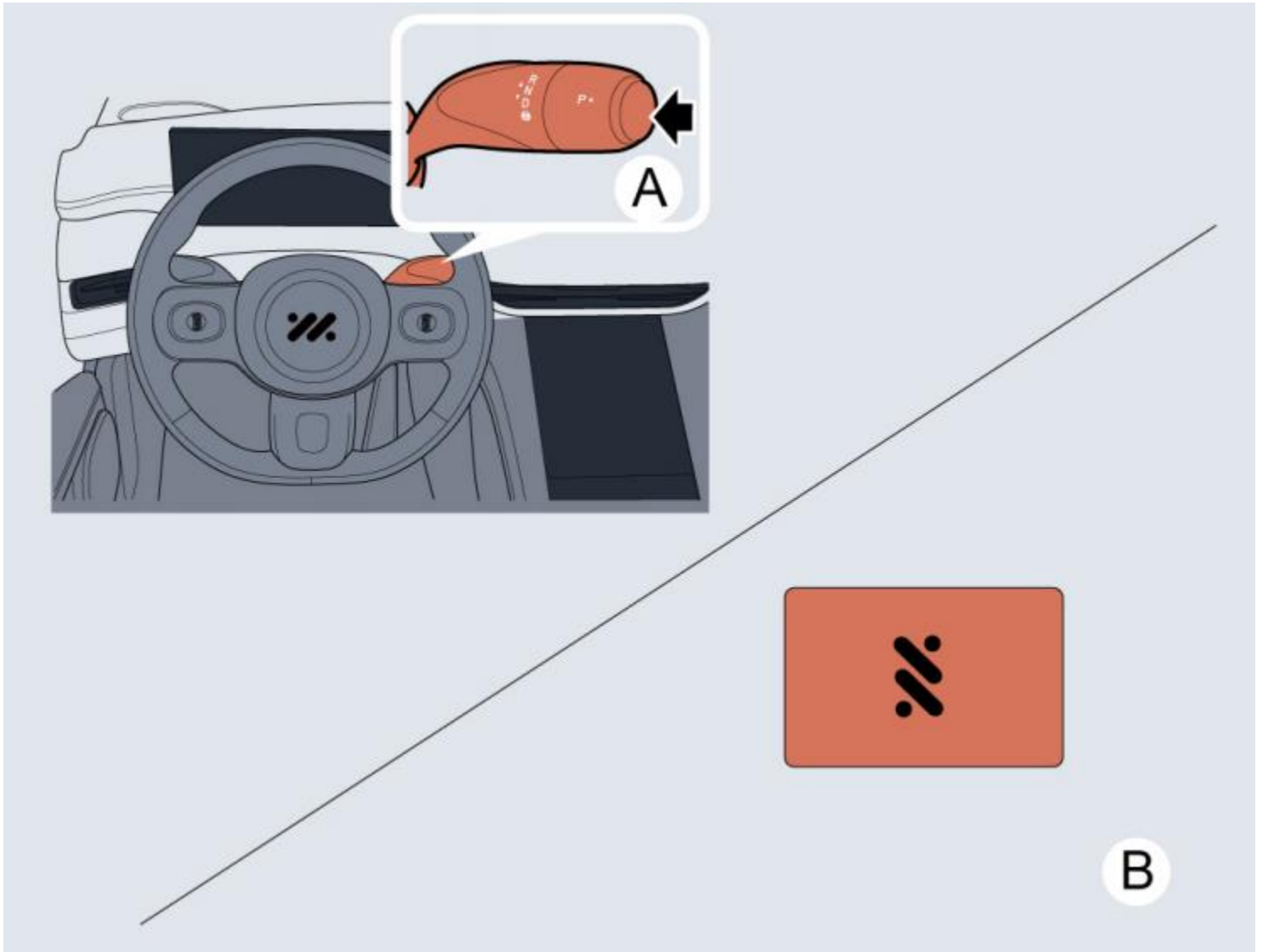

1. After bringing the car to a stop, ALWAYS press the brake pedal;
2. Place the shift lever in P (A);
3. Carry a NFC card (B) to touch the card swiping area on pillar B exterior trim panel on the driver side and keep for several seconds to turn off the power system, and lock the vehicle.

Maintenance

Inspection and Maintenance

Regular Maintenance

The safety, reliability and performance of your vehicle will depend partly on how well it is maintained. You must maintain your vehicle according to the requirements in the Owner's Manual.

Note: If the vehicle is not maintained or the displayed values are not reset after maintenance, the maintenance display cannot provide correct information.

Maintenance History

After each maintenance, always ask your local Authorised Dealer to register the maintenance.

Brake Fluid Replacement

Replace the brake fluid according to the requirements in the Owner's Manual.

Note: Additional cost should be paid for replacement of the brake fluid.

Coolant Replacement

The coolant (anti-freeze and water solution) should be replaced according to the requirements in the Owner's Manual.

Note: Additional cost should be paid for coolant replacement.

Special Maintenance

If your vehicle is frequently used in dusty conditions, or operated in extreme climates where sub-zero or very high ambient temperatures are normal, more frequent attention may need to be paid to maintenance requirements. You should carry out special maintenance (refer to Owner's Manual) or contact your Authorised Repairer.

Warning: Any significant or sudden drop in fluid levels, or uneven tyre wear, should be reported without delay to Authorised Repairer.

Routine Check

In addition to the maintenance referred to previously, some simple checks must be carried out more frequently.

Daily check

- Operation of lights, horn, wipers, washers and warning lights.
- Operation of seat belts and brakes.
- Look for fluid deposits underneath the car that might indicate a leak.
- Check tyre appearance.

Periodical check

- Coolant level.
- Brake fluid level.
- Windscreen washer fluid level.
- Operate air conditioning.

Maintenance Safety

Warning: Cooling fans may commence operating after engine flameout, and continue operating for a couple of minutes. Keep clear of all fans while working in the front compartment.

Observe the following safety precautions at all times during maintenance and service:

- If the vehicle has been driven recently, **DO NOT TOUCH** cooling system components until the drive motor has been fully cooled down.
- **DO NOT TOUCH** electrical leads or components when the Start switch is turned on.
- **DO NOT** work underneath the vehicle with a jack as the means of support.
- Wear protective clothing and work gloves.
- Remove watches and jewelry before working in the front compartment.
- **DO NOT** allow tools or metal parts of the vehicle to make contact with the battery leads or terminals.

Toxic Liquid

Fluids used in the vehicle are poisonous and shall not be swallowed or brought into contact with open wounds. These include: battery acid, coolant, brake fluid and windscreen washer fluid. For your own safety, **ALWAYS** read and obey all instructions on labels and containers.

Bonnet

Opening the Bonnet

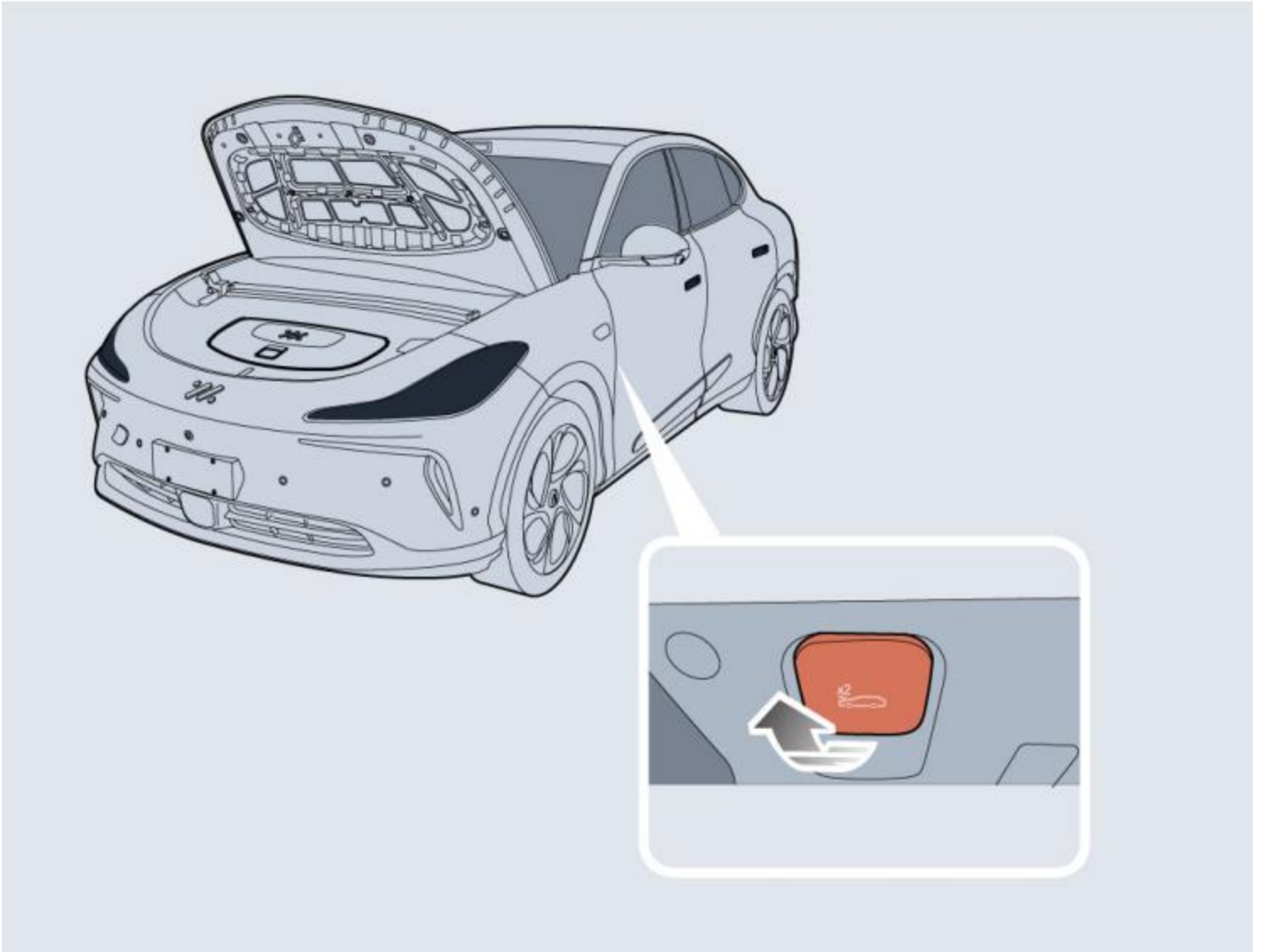

1. Pull the bonnet opening handle twice continuously inside the vehicle to unlock the bonnet.
2. After unlocking the bonnet, go to the front of the vehicle to lift it.

Closing the Bonnet

Warning: For safety reasons, the bonnet shall be closed well when driving. Therefore you must check after closing the bonnet that the bonnet is securely latched, e.g. the bonnet edge is flush with the body of the vehicle.

Warning: You should stop the car immediately when safety permits and close the bonnet if it is not closed fully when driving.

Warning: Beware of injury to hands while fully closing the bonnet with a downward force.

Warning: In extreme temperature environment, frost or ice may form on the surface of the gas spring piston rod of the bonnet. It is necessary to remove it before closing the bonnet.

Hold the bonnet with both hands, lower it close to the locking position, and then press the front end of the bonnet with both hands until it is fully locked.

Battery

Battery Maintenance

Warning: DO NOT leave electrical appliances switched on for a long time when the vehicle is not started, the battery may become flat, causing failure to start the engine, and reduction of the battery's service life.

Warning: LVBM has a built-in battery management system, thus it is prohibited to dismantle the battery to avoid damage to LVBM or cause personal injury.

Warning: Disconnect LVBM negative battery cable before part replacement and vehicle repair and check.

Warning: If the LVBM is charged using professional device, the charging current should not exceed twice the rated capacity and the charging voltage should not exceed 14.4V. In addition, since the LVBM needs to communicate with the vehicle before it is used properly and charged safely and quickly, it is important to ensure that connectors and harnesses are properly and securely connected.

Warning: Do not remove LVBM for charging without authorization.

The vehicle is equipped with a 12V low-voltage lithium battery system, referred to as LVBM, which is maintenance-free and located in the trunk.

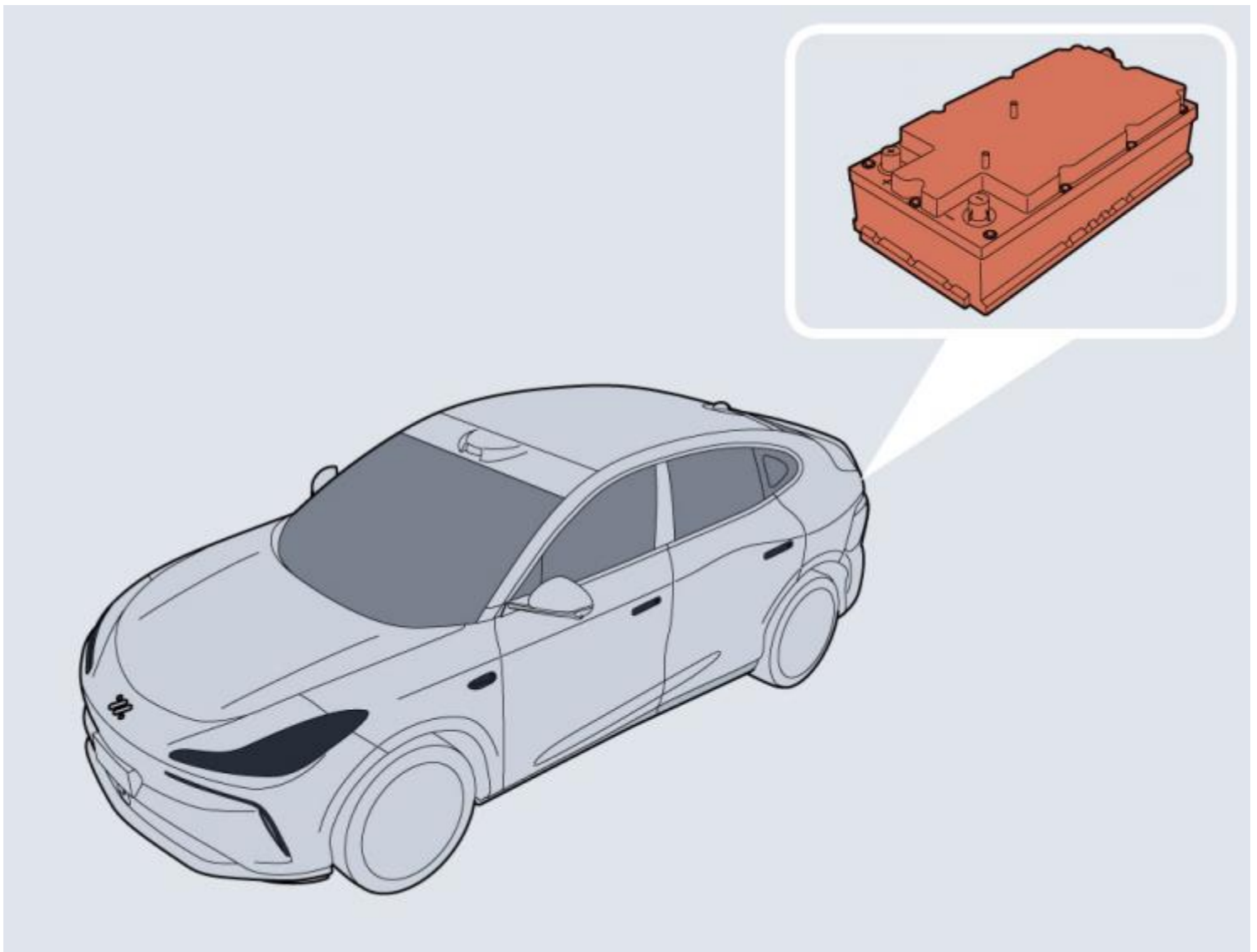

When the power battery is fully charged, the vehicle can charge the LVBM through the power battery to extend the LVBM endurance. According to the current load condition and the status of the battery, the system may limit the power of some electrical appliances, please start the vehicle as soon as possible to charge the LVBM, and keep the vehicle running for 1 - 2 hours.

Note: It is recommended to start the vehicle and run it for half an hour every week to help extend the service life of the battery. If the vehicle is stored for a long period of time (more than 1 month), remove the negative cable from the battery. Make sure that the vehicle is powered off before connecting or disconnecting the negative battery cable.

Battery Replacement

Please contact an Authorised Repairer to remove and install the battery. Only fit a replacement battery of the same type and specification as the original to maintain the correct vehicle functionality.



Used batteries are harmful to the environment, therefore, they must be disposed of using an approved method and should be recycled by a professional company. Please consult an Authorised Repairer for more details.

Cooling System

Coolant Check and Top Up

Warning: DO NOT remove the coolant expansion tank cap when the cooling system is hot - escaping steam and hot coolant could cause serious injury.

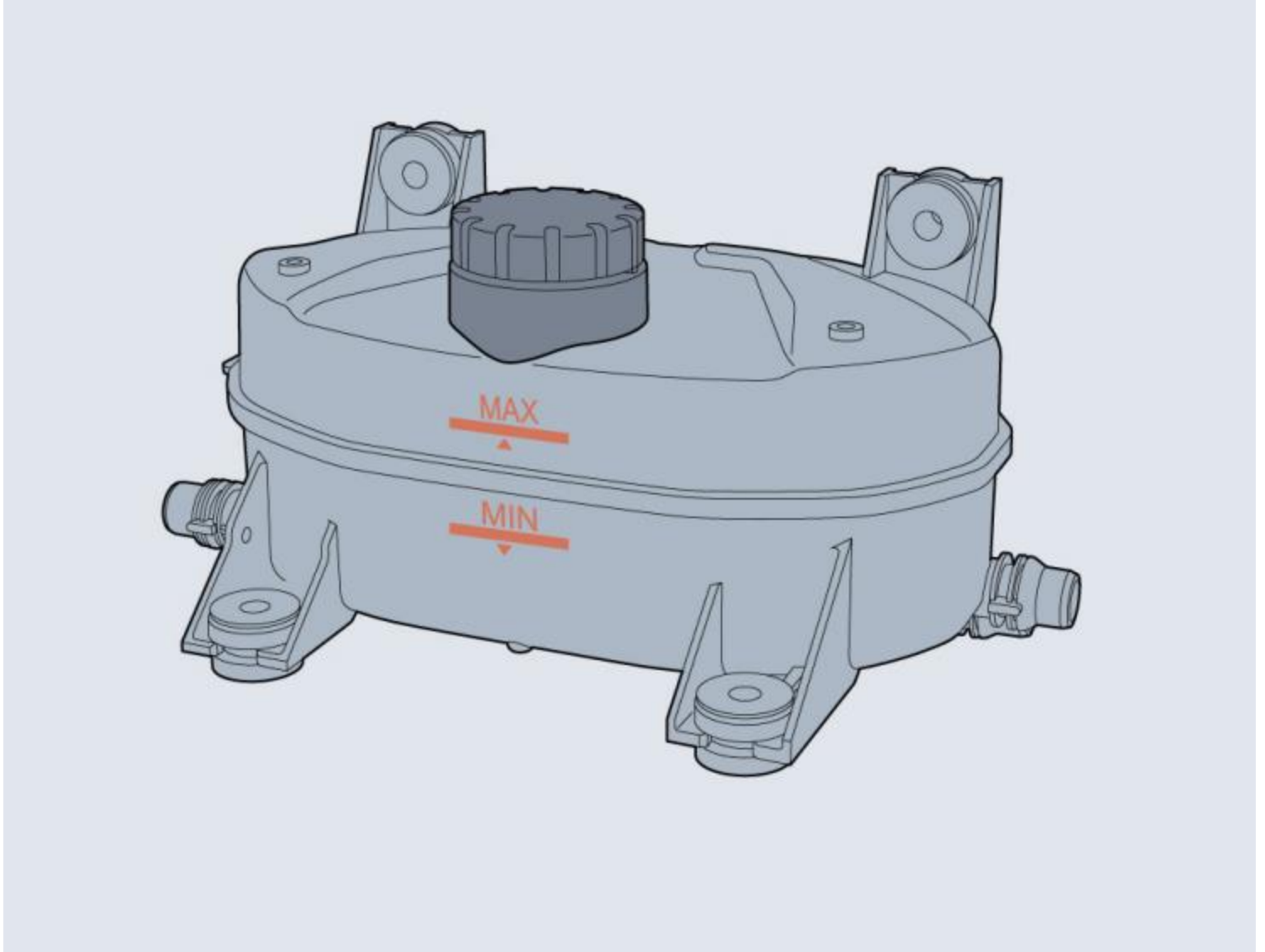

It is recommended that the cooling system should be checked weekly when the cooling system is cold and with the car resting on level ground. If the level is lower than 'MIN' mark, open the coolant expansion tank cap and top up coolant, but the level shall not be higher than 'MAX' mark.

Note: Prevent coolant coming into contact with the vehicle body when adding coolant. Coolant will damage painted surface. If the coolant level falls appreciably during a short period, the cooling system leakage may occur, please have it serviced in time by an Authorised Repairer.

Coolant Specification

Warning: Coolant is poisonous and can be fatal if swallowed - keep coolant containers sealed and out of the reach of children. If accidental contact of coolant by children is suspected, seek medical assistance immediately.

Warning: Prevent the coolant coming into contact with the skin or eyes. If this occurs, rinse immediately with plenty of water. If eyes are still red, painful or uncomfortable, seek medical attention immediately.

Please use the coolant recommended and certified. Refer to 'Recommended Fluids and Capacities' in "Technical Data" chapter.

Note: Refilling of any additives inapplicable to this vehicle into coolant may damage the components to be protected. You are recommended to use the additives certified, please consult your Authorised Repairer for details.

Brake System

Brake Pads

Warning: DO NOT rest your foot on the brake pedal while driving; this may overheat the brakes, reduce their efficiency and cause excessive wear to the brake components!

The free stroke of brake pedal is in the range of 0~30mm.

Reasonable usage scope of brake friction pair: not less than 3mm thickness of brake pads, 28~30mm for front brake disc, and 23~25mm for rear brake disc.

For the first 1500 km, you should avoid situations where heavy braking is required.

Please ensure that all the brake components are examined for wear at the correct intervals, and replaced when necessary to ensure long-term safety during the interval prescribed according to the requirements in the Owner's Manual.

The vehicle needs to run in for 800 km after the brake pad or disc is replaced.

Brake Fluid Check and Top Up

Warning: Brake fluid is highly toxic, keep containers sealed and stored out of the reach of children. If accidental contact of brake fluid is suspected, seek medical attention immediately!

Warning: Prevent brake fluid coming into contact with the skin or eyes. If this occurs, rinse immediately with plenty of water. If eyes are still red, painful or uncomfortable, seek medical attention immediately!

The brake fluid level should be checked weekly when the system is cold and with the car on level ground. Clean the cover first before opening the brake fluid reservoir.

The brake fluid level can be seen through the reservoir and should be maintained between the 'MAX' and 'MIN' marks.

Note: Do not allow the level to drop below the "MIN" mark or rise above "MAX" mark.

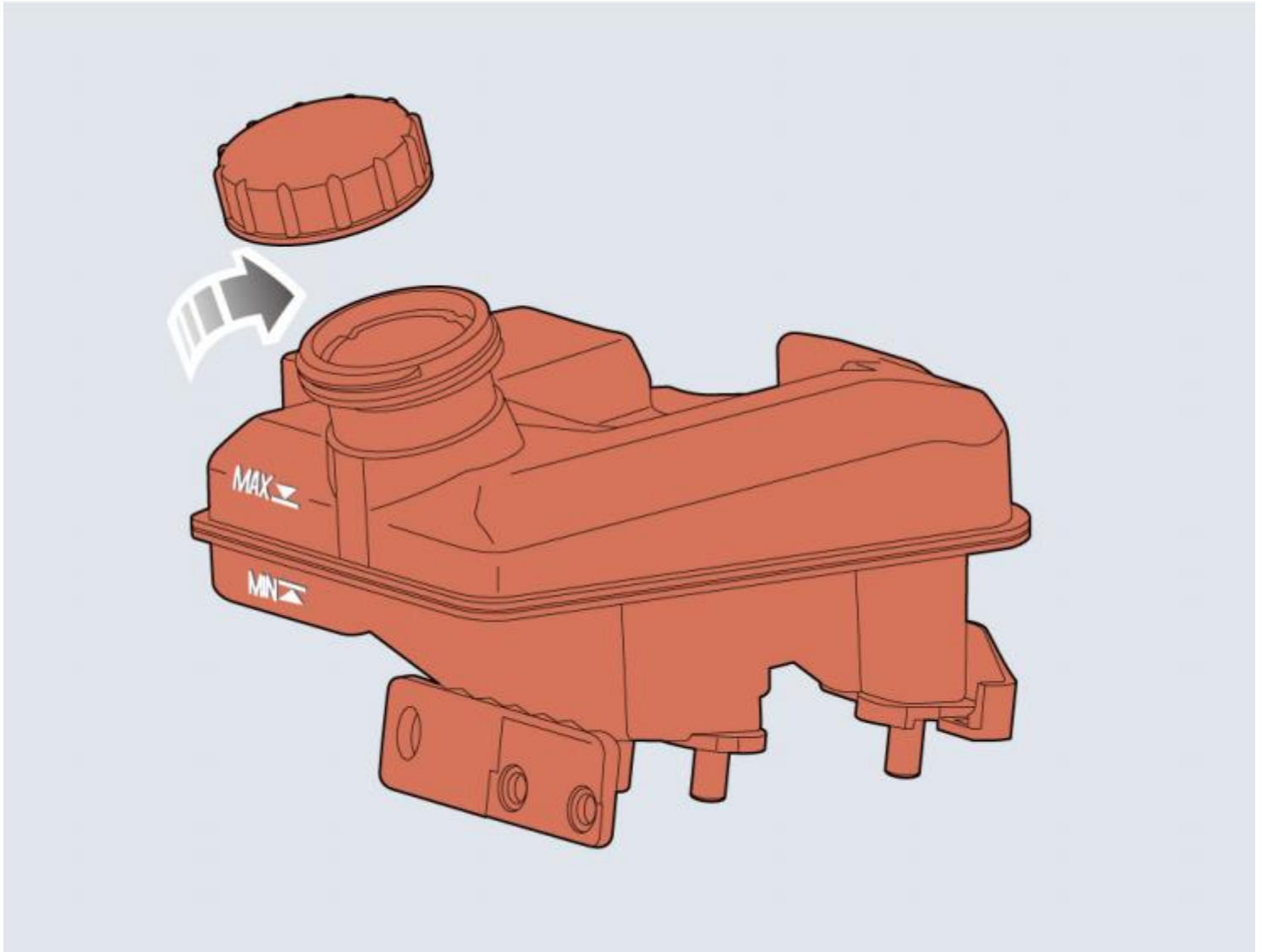

Note: Brake fluid will damage painted surfaces. If you accidentally spill the brake fluid on the painted surface, soak up any spillage with an absorbent cloth immediately and wash the area with water or car shampoo.

Brake Fluid Specification

Please use the brake fluid recommended and certified. Refer to "Recommended Fluids and Capacities" under "Dynamic Parameters" in the "Specification Parameters" chapter.

IMPORTANT

Replace brake fluid regularly according to the Warranty and Maintenance Manual.

High-voltage Battery Pack

Service Life of High-voltage Battery Pack

DO NOT park the vehicle in conditions where the ambient temperature exceeds 45°C for more than 15 days. This will affect the operational performance of the vehicle and the service life of the high-voltage battery pack.

To maintain or improve the service life of the high-voltage battery pack, it is recommended that you use a slow charging method wherever possible. Fast charging is mainly used for long distance journeys or emergencies.

If there is a serious accident, please contact Authorised Repairer for inspection after the accident is handled.

Warning: Do not disassemble the high-voltage battery pack for repair without approval, IM Motors will not fulfill the warranty terms otherwise.

IMPORTANT

Unauthorised maintenance personnel are strictly prohibited from disassembling and assembling the high-voltage battery pack and related components.

Equalisation Charging

Where possible it is recommended that you carry out a slow charging (battery equalisation) every month to extend the service life of high-voltage battery pack.

Equalisation charging means that after a normal charging process the battery management system will enter a mode where it will attempt to equalise the charge of every battery cell, so as to ensure the overall performance of high-voltage battery pack.

Long-term Parking

It is recommended using the vehicle at least once a month.

If the vehicle is parked for a long time, it shall be charged at least once every 3 months (the battery power shall remain above 50% on the instrument pack after charging). It is strictly prohibited to park the vehicle for more than 7 days when the high-voltage battery pack is low on power (no valid driving range shown on the instrument pack), otherwise IM Motors will not fulfill the warranty terms for resulted damage of high-voltage battery pack.

Washer

Washer Fluid Check and Top Up

Warning: Washer fluid is flammable. DO NOT allow washer fluid to come into contact with naked flames or sources of ignition.

Warning: When filling the washer fluid, DO NOT let the washer fluid spill on parts around the engine or on the paint surface of vehicle body. In case the washer fluid is spilled on hands or other parts of the body, please immediately wash with clean water.

Check the washer fluid level regularly. When the level of washer fluid is low, please top up the washer fluid as instructed. Use the washer fluid recommended and certified. Refer to "Recommended Fluids and Capacities" in the "Specification Parameters" chapter.

If your vehicle is equipped with a washer fluid level sensor, there will be relevant text prompts on the driver's screen when the liquid level is very low.



Note: DO NOT use an anti-freeze or acid solution (such as diluent of vinegar) in the washer reservoir - anti-freeze will damage paintwork while acid solution will damage the washer motor.

IMPORTANT

Use the washer fluid recommended and certified. Misuse of washer fluid in winter may cause damage to the washer motor due to freezing.

Using the washer switch when there is no washer fluid may cause damage to the washer motor.

Operating the wipers when the windscreen is dry and there is no washer fluid may cause damage to the windscreen and wipers. Please spray the washer fluid and start the wipers when there is adequate washer fluid.

Washer Nozzles

The windscreen washer nozzle is located on the A/C air intake grille panel.

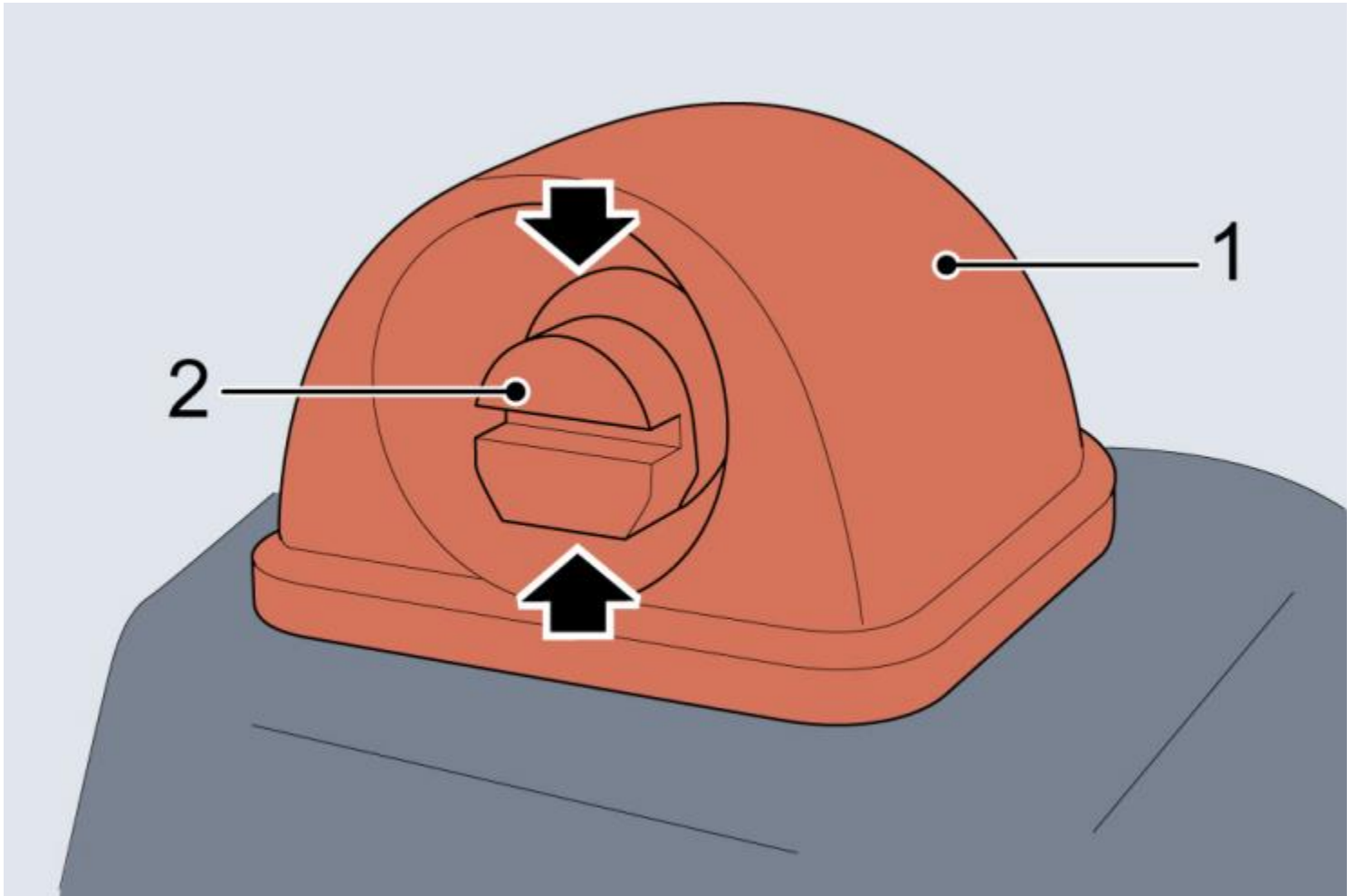

The angle of windscreen washer nozzle is configured during delivery. Do not make any adjustment to its direction. To adjust the windscreen washer nozzle, you can insert a small flat-bladed screwdriver in the gap (the area as indicated by the arrow) between the housing (1) and the nozzle (2) and turn it upward or downward slightly to achieve an appropriate injection angle. Operate the washer to spray water periodically to check if the washer nozzles are clean and in the correct direction. If the nozzle is obstructed, insert a needle or thin metal wire into the hole to remove the obstruction.

Wiper

Wiper Blades

IMPORTANT

Grease, silicon and petroleum products impair the blade's wiping capability. Clean the wiper blades in warm soap water, and check their status periodically.

Clean the windscreen frequently. **DO NOT** use wipers to remove the sediment on the windscreen, it will reduce their effect and their life span.

If signs of hardness or cracking in the rubber are found, or if the wipers leave streaks or unwiped areas on the windscreen, then the wiper blades should be replaced.

Clean the windscreen regularly with an approved glass cleaner and ensure the windscreen is thoroughly cleaned before fitting replacement wiper blades.

Only fit replacement wiper blades that are identical to the original specification.

If the wipers or windscreens are covered with ice or frozen, clean ice and snow from the wipers and windscreens before attempting to operate them to avoid possible damage.

Replacing Front Windscreen Wiper Blades



1. Keep the bonnet closed.
2. To put the wipers into service mode: You can set the path on the central screen: "Settings" - "General" - "Vehicle Power Supply" to turn off the vehicle power supply. Operate the wash and wipe button to Single Wipe position (see 'Wash and Wipe' in 'Before Using the Vehicle' section) and release within 20 seconds after powering off the vehicle, the wiper will automatically move to service position, and stop on the windscreen. You can also set the path on the central screen: "Settings" - "General" - "Wiper Service Mode", then the wiper will automatically move to service position, and stop on the windscreen.
3. Lift the wiper arm away from the windscreen.
4. Press the button on the wiper arm (as illustrated), and pull the upper end of the wiper blade outward to disengage from the wiper arm.
5. Unhook the blade from the wiper arm and discard.
6. Locate the connector of new wiper blade into the slot of the wiper arm.
7. Push the wiper blade towards the wiper arm until the wiper blade is fully embedded.
8. Check whether the wiper blade is fitted correctly to the arm before positioning the wiper assembly on the windscreen.
9. After the vehicle is powered on, the wiper will exit the service mode and automatically return to its original position.

Tyres

Caring for Your Tyres

Your vehicle is equipped with summer tyres which are not suitable for long-term use and storage at low temperatures. Because low temperatures may lead to a decrease in summer tyre's performance, and even cracks may appear on the tread. If you often drive at low temperatures, or on the snowy and icy roads, it is recommended to install winter tyres and anti-skid chains. Refer to "Driving in Winter" in this section for details.

The damage of a tyre or rim may happen unnoticeably. If abnormal vibration or deviation is experienced, that means the tyre may have been damaged. If you suspect that a tyre is damaged, please slow down immediately, and stop your vehicle to check the tyre for damage. If you can't see the damage from the outside, continue driving the vehicle slowly to a nearest Authorised Repairer for inspection and service.

During the use of tyres and wheels, attention should be paid to:

1. New tyres may not have optimum adhesion properties, please run at moderate speed in appropriately careful driving style for the first 500km.
2. You can only drive at low speed when passing curbs or similar sections, and pass the wheels through the curbs at right angle as far as possible.
3. Regularly check tyres for damage (punctures, scratches, cracks and pits), and remove any foreign objects from the tread in time.
4. The valve dust cap must be fitted to prevent dust from entering the valve.
5. If the tyre is to be removed, always mark the tyre/wheel orientation to ensure correct refitment.
6. Store the removed wheels or tyres in cool and dry places to keep out of the sun as far as possible.
7. The summer tyres must be stored at room temperature when not in use. If the tyres have been used or stored at low temperatures, they should be placed in a space of not less than 5°C for 24 hours or above before you install them or drive a vehicle with them.
8. Do not directly heat or blow warm air to the tyres.

Service Life of Tyres

Rational tyre pressure and moderate driving style can extend tyre life. Recommendations during use are as follows:

- Tyre pressures should be checked monthly when the tyres are cold.
- Avoid cornering at excessive speeds;
- Regularly check tyres for abnormal wear patterns.
- When the vehicle is to be parked for a long time, please move it at least once every two weeks and check the tyre pressure to prevent deformation of the tyres due to long-term stress.

The following factors affect the tyre life:

Tyre Pressure

Over or under-inflated tyres will cause the abnormal wear of the tyre, greatly shorten the service life, and have an adverse effect on the driving characteristics of the vehicle.

Driving Style

Fast driving, excessively harsh acceleration and braking whilst cornering will aggravate the tyre wear.

Wheel Balance

The wheels of a new vehicle are subject to dynamic balance testing, but out of balance wheels may still be caused due to the effects of various factors in operation. You shall conduct the dynamic balance for the wheels again since out of balance wheels will cause jitter of the steering mechanism and excessive wear in the tyres. In addition, each wheel must be rebalanced after new tyres are installed or tyres have been repaired.

Wheel Alignment Defect

Incorrect wheel alignment can cause excessive tyre wear and affect vehicle safety. If the tyres show signs of abnormal wear, check the wheel alignment in time and seek advice from an Authorised Repairer.

Check on Your Tyres

Warning: USING DEFECTIVE TYRES ARE DANGEROUS! DO NOT drive if any tyre is damaged, is excessively worn, or is inflated to an improper pressure.

Warning: It is recommended to install the tyres consistent with the original specifications. Alternative tyres of a different specification or unqualified tyres may adversely affect the vehicle's driving characteristics and safety. In order to better guarantee your driving safety, it is suggested that you consult an Authorised Repairer.

Always drive with consideration for the condition of the tyres, and regularly inspect the tread and side walls for any sign of distortion (bulges), cuts or wear.

Note: Avoid tyre contact with oil, grease and fuel.

Tyre Pressure

Warning: Before a long distance journey, the tyre pressure must be checked.

Tyre pressures should be checked monthly when the tyres are cold.

If it is necessary to check the tyres when they are warm, you should expect the pressures to have increased by 30~40 kPa (i.e. 0.3 ~ 0.4 bar). In this circumstance, NEVER let air out of the tyres in order to match the recommended pressures (cold) in the technical data.

Valves

Keep the valve caps screwed down firmly - they prevent dirt from entering the valve. Check the valve for leaks (listen for a tell-tale hissing) when you check the tyre pressure. Your vehicle is equipped with tyres which may not leak if penetrated by a sharp object, provided the object remains in the tyre. If you are aware of this occurring, reduce speed immediately and drive with caution until the spare wheel can be fitted, or repairs undertaken.

Note: If the sidewall of the tyre is damaged or distorted, replace the tyre immediately, do not attempt a repair.

Tyre Wear Indicators

The tyres fitted as original equipment have 1.6 mm-high wear indicators at their tread pattern bottom, vertical with the wheel rolling direction and evenly distributed around the circumference. The mark on the tyre side such as capital letters TWI or triangular symbol shows the location of wear indicator.

When the tread has worn down to 1.6 mm or below, the indicators will come to the surface of the tread pattern, producing the effect of a continuous band of rubber across the width of the tyre.

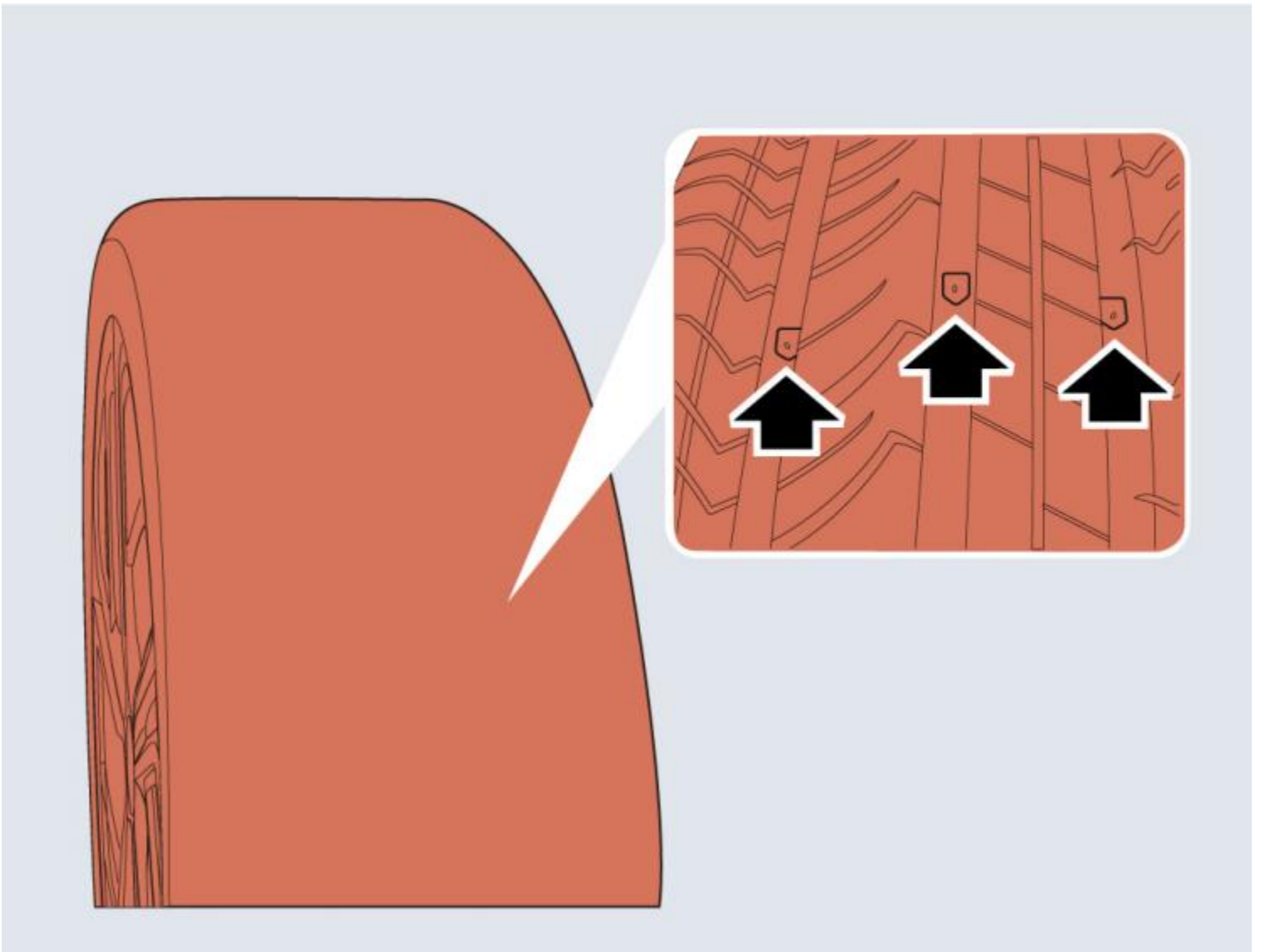

IMPORTANT

The tyre must be replaced when it is worn to reveal the wear indicator, or there might be the risk of accident.

Tyre Rotation

Warning: The tyre rotation applies to the vehicles with the same front and rear wheel specifications. Tyre rotation is not recommended when the front and rear wheel specifications are inconsistent.

Warning: The side of a tyre with directional tread patterns is marked with an arrow to indicate direction, and the tyre must be used in this 'direction of rotation' (DOR) to ensure optimal driving performance. This type of tyres CANNOT be swapped from side to side, but swapping between front and rear wheels is feasible.

It is recommended that you swap wheels at irregular intervals in order to equalise tyre wear when the front and rear wheel specifications are consistent.

When the tyres are worn seriously, it is recommended to swap the front and rear wheels as shown in illustration. This can prevent tyres from uneven wear, prolong the life span and balance tyre fatigue.

It is favorable to swap the driving wheels from front to rear and exchange non-driving wheels across.

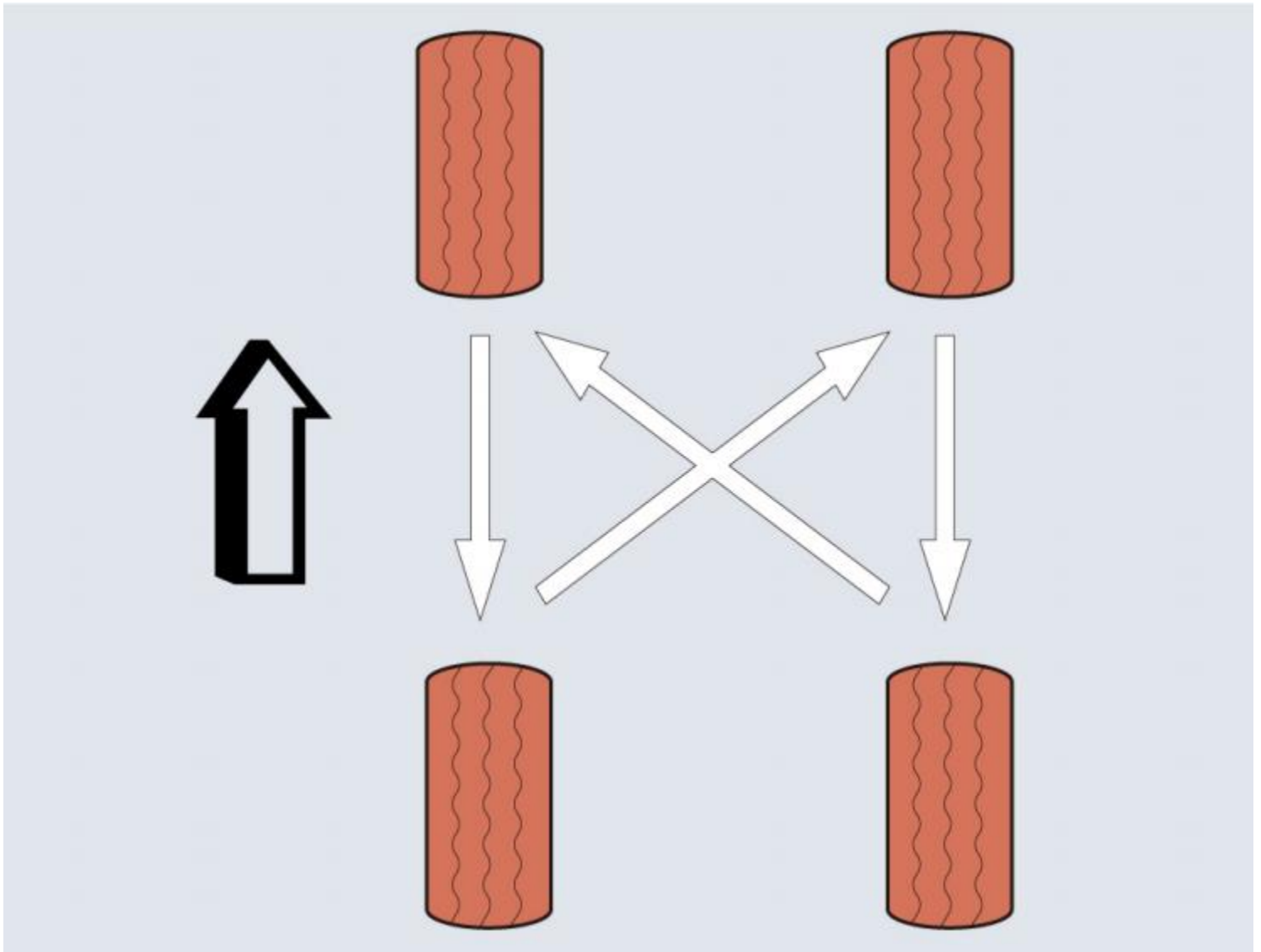

Note: The TPMS self-learning is required after the wheel fitment rotation, please consult an Authorised Repairer for details.

Driving in Winter

Winter tyres

This series of models are not equipped with winter tyres when leaving the factory.

Winter tyres can improve the traction on snowy and icy roads. If the vehicle frequently runs on snowy and icy roads, you should consider installing winter tyres on the vehicle. When choosing winter tyres, the owners should note that:

- The four winter tyres must have the same brand and type;
- Only tyres with the same specifications, load range and speed class as the original tyres should be used.

The installation of winter tyres may result in reduced traction on dry roads, increased road noise, and shortened tread life. After the replacement of winter tyres, it is necessary to note the changes in vehicle operation and braking performance.

Anti-skid chains

Unsuitable anti-skid chains may damage the tyres, wheels, suspension, brakes or bodywork of your vehicle.

Please pay attention to the following requirements in the usage:

- The anti-skid chains can only be fitted on the rear drive wheels;
- The thickness of anti-skid chains shall not exceed 15 mm;
- Please always observe the installation and tension instructions for the anti-skid chains, as well as the speed limitations of different roads;
- Do not drive faster than 50 km/h;
- To avoid the tyre damage and excessive wear of the anti-skid chains, the anti-skid chains must be removed while driving on the road without snow.

Size and Specifications of Wheels and Tyres Supporting Anti-skid Chains for this Vehicle (rear drive wheels)	
Wheel Rim Size	9J×20
Tyre Size	255/45 R20

Note: Before choosing the anti-skid chain, please ensure that the vehicle's rim and tyre specifications are consistent with the above table, so as to avoid failure to install the anti-skid chains.

Cleaning and Vehicle Care

Automobile External Care

Warning: Abuse of care products may be harmful to health, care products must be safely stored, especially can't let children contact, or it will have the hazard of poisoning.

Vehicle Cleaning

Warning: You can only clean the vehicle with the Start switch off, or there might be the risk of accident.

Warning: For vehicle cleaning in winter, moisture or icing in the braking system will reduce the braking effect, which may have the risk of accident.

Warning: DO NOT use a high pressure water jet to clean the engine compartment, damage to the car's electronic systems may occur.

Frequent cleaning and waxing can effectively protect the vehicle against harmful environmental impacts. Some covered areas, for example, doorsill footstep, sealed parts, cover plate, etc. should be cleaned periodically. The time interval of vehicle cleaning depends on many factors. For example:

- Operating frequency;
- Places for vehicle parking and storage, etc.;
- Seasons;
- Climatic conditions;
- Environmental impacts.

The longer adhesion of insect infectants, bird droppings, resin, road dust and industrial dust, asphalt, soot particles, snow melting salt and other erosive sediments to the automotive paint, the greater their adverse effects are. Too high temperature, such as intensive solar radiation, will also intensify the erosion. Therefore, please clean your vehicle according to the actual situation.

After the end of the salt spilling period in winter, be sure to thoroughly clean the bottom of the vehicle once.

Automatic Cleaning Equipment

The automotive paint has certain abrasion resistance, so you may absolutely clean the vehicle with automatic cleaning equipment in general. In fact, the structure of the cleaning equipment, the filtration of water, and the types of cleaning and curing agents have a certain impact on car paint. Please choose a cleaning equipment that is suitable for your car.

Before automatic cleaning, you shall close the windows and sunroof, and inquiry the cleaning equipment operator whether the roof antenna is to be removed, if your vehicle is provided with spoiler, roof rack, radio antenna and other installed parts, you need to tell the cleaning equipment operator.

Manual Cleaning

When manually cleaning your vehicle, please carefully choose cleaning agents according to actual needs and rinse the vehicle with clean water after using the cleaning agents.

IMPORTANT

- Do not clean the vehicle under direct sunlight, or you will have the risk of paint damage.
- For vehicle cleaning in winter, in the case of vehicle hosing, please note that the ejected water beam should not align the door locks, door joints and sunroof joints, or there will be the risk of being frozen.
- Do not wipe the vehicle with rough kitchen sponge or similar objects, or there will be the risk of damage to the surface.
- For cleaning headlamps, do not use dry dishcloth or sponge, soapy water is recommended.

Cleaning with High Pressure Cleaner

You must abide by the operation instructions for cleaning the vehicle with a high pressure cleaner, especially the pressure and jet distance should be kept in an enough distance from the flexible material (such as rubber hose or sound insulation).

Do not use a circle beam nozzle or rotary nozzle, especially the tyres are never allowed to be cleaned with the circle beam nozzle, and it may cause damage even the jet distance is long and action time is very short.

IMPORTANT

- Please pay attention to the operating instructions of high pressure cleaner.
- Soft parts on the vehicle should be kept in a large enough distance from the high pressure cleaner.

Waxing

A high quality wax layer can be very good to protect the automotive paint against harmful environmental impacts, even have a protective effect on slight hard crashes. If you find that water drops can no longer smoothly roll down on clean paint, you shall recoat the vehicle with a high quality hard wax curing agent. You shall apply hard wax at least twice a year to protect the automotive paint even in regular use of wax curing agent for cleaning the vehicle with the automatic cleaning equipment.

Polishing the Paintwork

Polishing is required only when the automotive paint has tarnished and can not return even by waxing.

If the applied polishing agent does not contain waxy composition, you must wax the paint after polishing; occasionally treat the paint surface with an approved polish containing the following properties:

- Very mild abrasives to remove surface contamination without removing or damaging the paint.
- Filling materials to cover the scratches.
- Wax to provide a protective coating on the paint surface.

Note: Do not treat parts or plastic parts coated with matte paint by using the polishing agent.

Paint Damage

A small area of paint damage, such as scratches or damages after being struck by stones, shall be immediately coated with paint to avoid rusting. If rusting has appeared, you must remove it thoroughly, then apply anti-corrosive primer to this portion, and finally apply finish.

Matte Paint

Matte paint is a special type of coating that requires special care in car washing and car care.

It is recommended to wash the car manually and do not use rough sponges or cloth. Do not use excessive force when cleaning and wiping.

Avoid washing the car in direct sunlight.

- Do not use high pressure water jet or steam to clean the vehicle. If the vehicle is quite dirty, a pre-cleaning is required before washing. Clean the body dust and other particles that may damage the paint surface first.
- Spray the vehicle body with a large amount of water, and use a soft sponge and neutral wax-free car wash solution to clean the vehicle from the roof downwards and then dry the vehicle body.

During the daily care of your vehicle, attention shall also be paid to:

- If the paint film comes into contact with resin or grease, as well as insect residue or bird excrement, please remove it immediately to avoid irreversible damage to the matte paint surface.
- If there are oil stains or fingerprints on the matte paint surface, immediately remove them with a clean cloth and do not use excessive force to avoid irreversible damage to the matte paint surface.
- To maintain the matte effect of the paint surface, abrasives, polishes, and waxes cannot be used, and the vehicle body cannot be polished.
- Do not use any stickers, pasters, magnets, or similar materials to prevent damage to the paint surface.
- Be sure to repair the paint film in a qualified professional repair workshop.

Wiper Blades

Wash in warm soapy water. DO NOT use spirit or petrol based cleaners.

Windows and Mirrors

Regularly clean all windows, inside and out, using an approved glass cleaner.

Windscreen: Clean the outside of the windscreen with glass cleaner before fitting new wiper blades.

Rear windscreen: Clean the inside with a soft cloth, using a side to side motion to avoid damaging the heating elements. DO NOT scrape the glass or use abrasive cleaning compositions – this will damage the heating elements.

Rearview mirrors: wash with soapy water. DO NOT use abrasive cleaning compositions or metal scraper.

Plastic Parts

Plastic parts can be cleaned by the conventional method of cleaning. When the stain is not easy to remove, you can use special curing agent for treatment, and the paint curing agent is not preferable for treatment of plastic parts.

Weather Strips

Rubber weather strips of doors, front and rear cover lids, sunroof and windows should be irregularly coated with rubber curing agent (such as silica gel spray) to keep their flexibility and extend the service life.

Wheels

Warning: Moisture or icing and snow melting salt may reduce braking effect, which may have the risk of accident.

You can prevent braking abrasive dust dirt and snow melting salt from attaching to the wheels by cleaning the wheels. Braking abrasive dust not easy to remove may be cleared with non-acid rim cleaner.

Light Alloy Wheels

In order to keep good appearance of the light alloy wheels, regular care is required for it, if snow melting salt and braking abrasive dust are not washed off regularly, the light alloy wheels will be eroded.

Please be sure to use non-acid special cleaner for cleaning. Do not use paint polishing agent or other products containing abrasives for wheel care, if the protective cover of paint has been damaged (such as damages after being stuck by stones), you must immediately repair the damaged part.

Protective Bottom Cover

Warning: Never add any protective bottom cover to the catalytic converter or the heat shield, it may ignite these substances and cause fire.

The bottom of the vehicle is coated with a special durable protective material, which can be safe against the effects of chemical and mechanical factors. But we recommend you to inspect the bottom of the vehicle and the protective layer of the chassis on a regular basis since the protective layer can not be protected against damages when the vehicle is in service, and it is preferable to inspect once before the cold season starts and after it comes to an end.

Automobile Internal Care

Condenser, Radiator and Cooling Fan

During the daily driving, condenser, radiator and cooling fan of the vehicle may accumulate dirt, thereby resulting in the deviations in A/C system, cooling system and noise. During the routine servicing and cleaning, if any dirt is found, flush with water or wipe with cloth. Be careful not to damage the fins of condenser and radiator and the cooling fan blade.

Plastic Parts, Artificial Leather and Fabrics

You can clean plastic parts and artificial leather with wet dishcloth. If the stain cannot be cleared, it is only allowed to wash these parts with the special solvent-free plastic cleaning and curing agent.

Cushions and fabric finishes at the doors, trunk lid panel, roof and other points shall be cleaned with special cleaner or dry foam and soft sponge.

Note: DO NOT polish dashboard components – these should remain non-reflective.

Airbag Covers

Warning: DO NOT allow airbag cover areas to be flooded with liquid and DO NOT use petrol, detergent, furniture cream or polishes.

To prevent damaging airbags, only use one wet cloth and upholstery cleaner to carefully clean the following areas:

- Steering wheel centre pad.
- Area of dashboard containing the passenger airbag.
- Area of roof lining which encloses the side head impact protection airbags.

Seat Belts

Warning: DO NOT use bleaches, dyes or cleaning solvents on seat belts.

Extend the belts, then use warm water and a non-detergent soap to clean. Allow the belts to dry naturally. DO NOT retract them or use them until they are completely dry.

Carpet and Fabrics

Before using diluted upholstery cleaner, test a concealed area first.

Leather

Due to the specificity and characteristics (such as sensitivity to oil, grease, dirt, etc.) of the leather type used in the vehicle, it is necessary to be thoughtful and detailed for application and care of automotive leather, for example, you might contaminate the leather seats with colours of dark, especially wet garment materials having dyeing problems. Any dust and dirt particles invading the leather pore folds and edge joints will wear leather surface. Therefore, you shall care about it regularly or according to the use of leather.

Clean leather trim with warm water and a non-detergent soap. Dry the leather with a dry, clean, lint-free cloth.

Care Suggestions

- Use specialized maintenance oil after each cleaning. The curing oil can nourish the leather, make it flexible, breathable and restore moisture, and can also establish a protective layer on its surface.
- Clean the leather every two to three months to remove stains in a timely manner.
- Remove stains left by pen ink, shoe cream, etc. as soon as possible.

Note: DO NOT use petrol, detergents, furniture creams or polishes as cleaning agents.

Instrument Pack and Entertainment Display

Clean with a soft dry cloth only.

Specifications and Parameters

Vehicle Identification

Vehicle Identification Number (VIN)

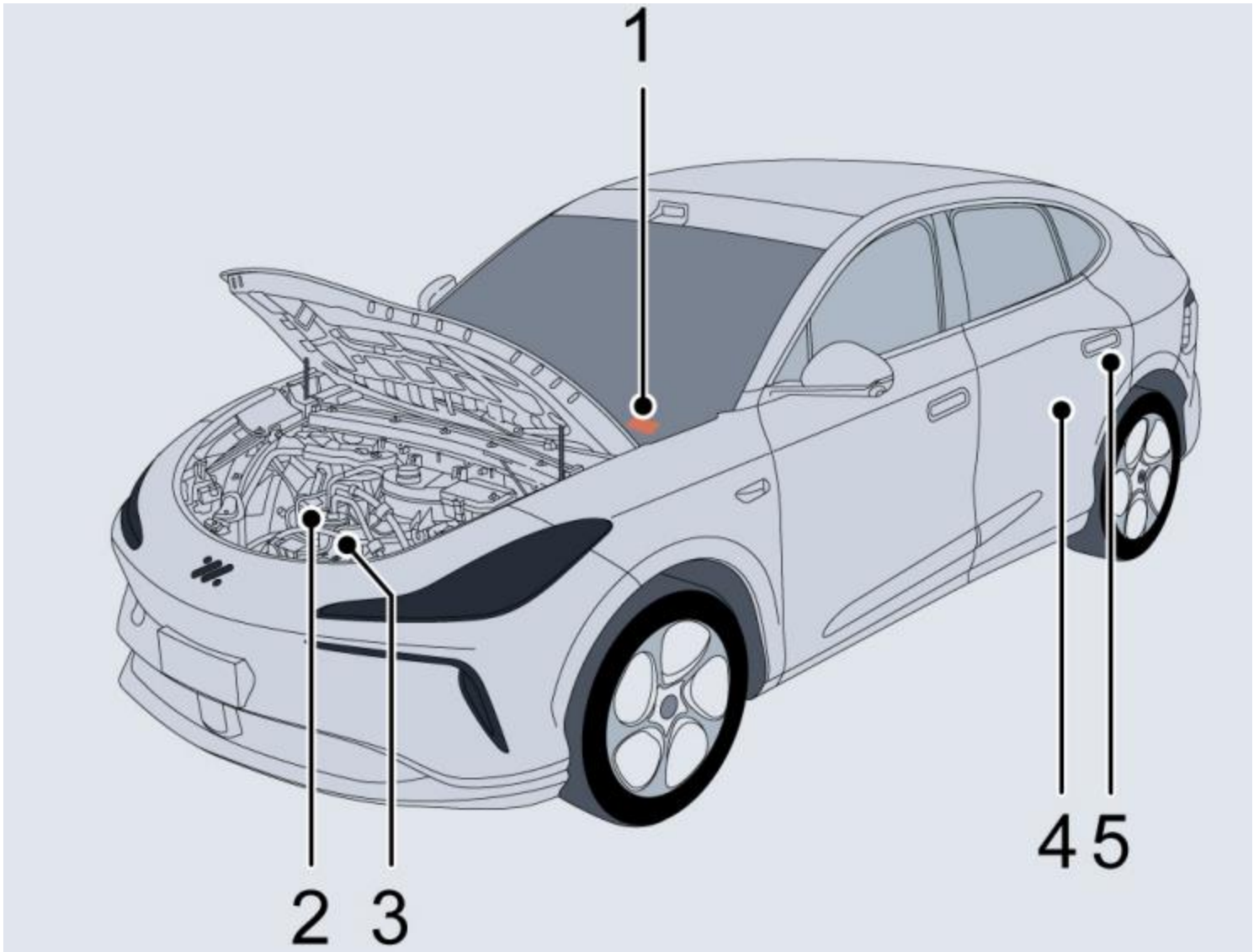

1. Vehicle Identification Number (VIN)
2. Drive Motor Number - Front
3. Electric Drive Unit Number - Front
4. Drive Motor Number - Rear
5. Electric Drive Unit Number - Rear

Always quote the Vehicle Identification Number (VIN) when communicating with your Authorised Repairer. If the drive motor or electric drive unit is involved, it may be necessary to provide the identification numbers of these assemblies.

Vehicle Identification Number (VIN) Location

- Stamped on the instrument panel visible through the bottom left hand corner of the windscreen;
- On the identification plate;
- On the cross beam facade of front passenger seat;
- On the inner side of the tailgate visible by opening the tailgate.

Note: The DLC of the vehicle is located above the accelerator pedal, and the VIN information can be read with the after-sale special scan tool.

Other Numbers

Front Axle Number*

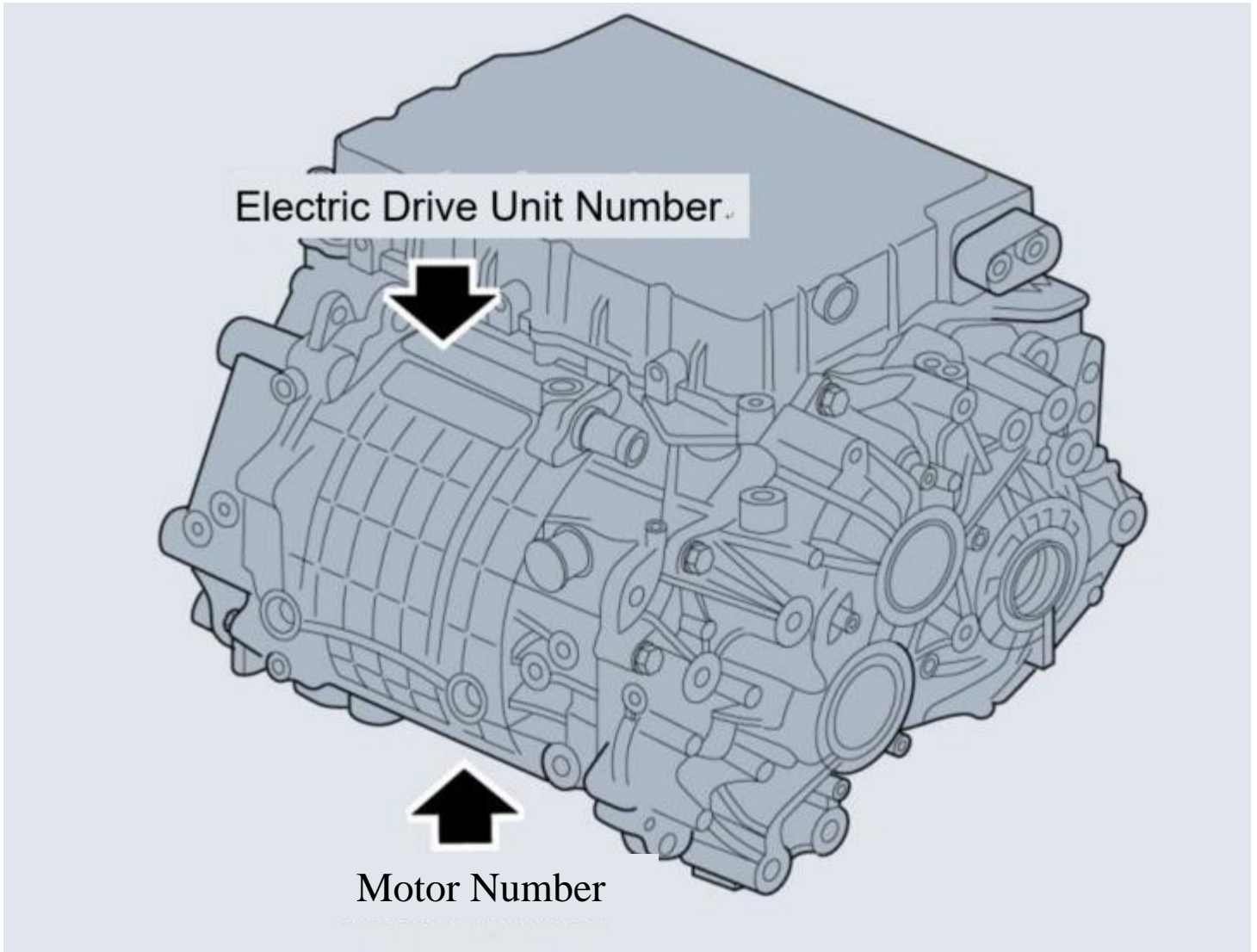

Rear Axle Number

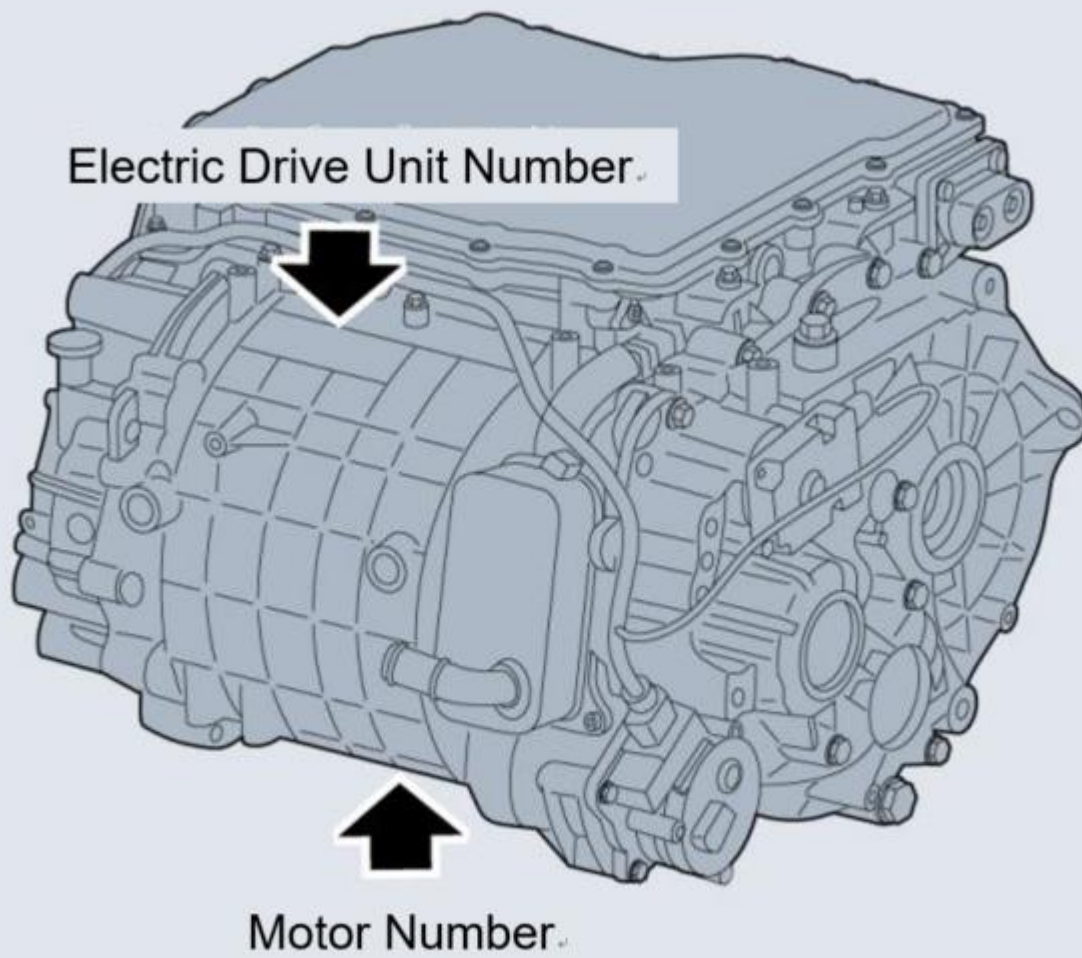

Rear Axle - Motor Code

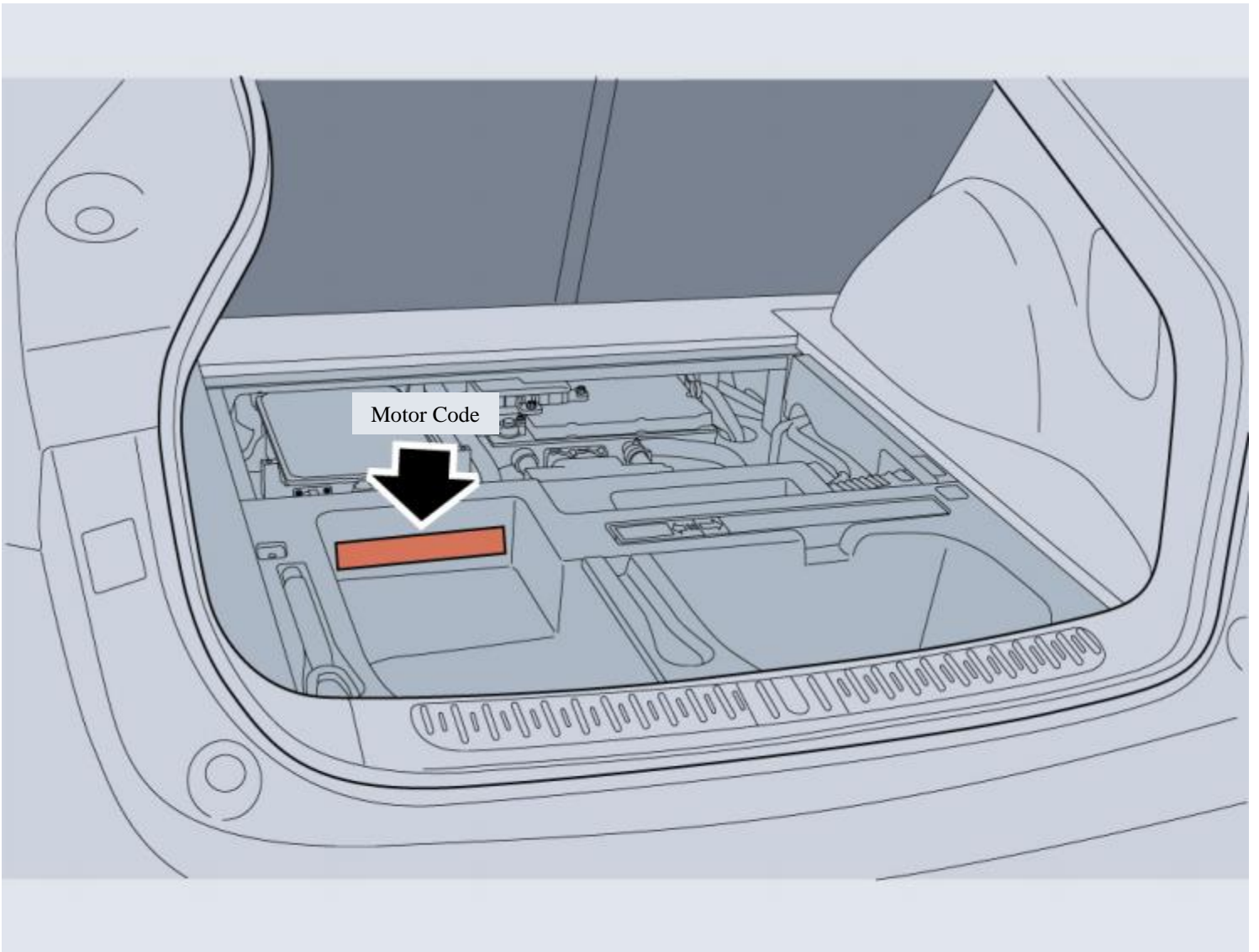

Vehicle Identification Plate

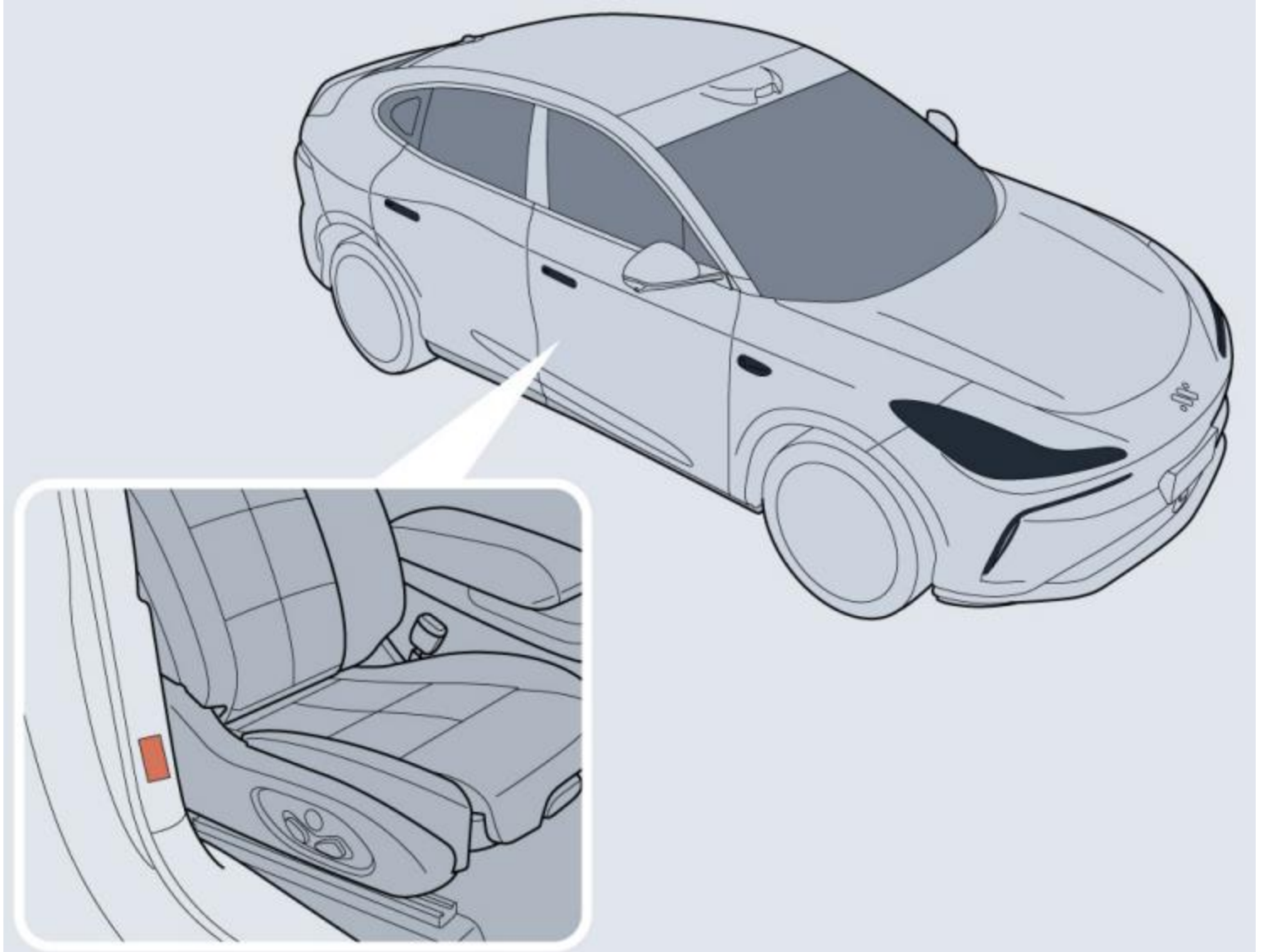

The identification plate is located at the lower side of right pillar B. It contains the following information:

- Brand
- Vehicle model
- Person in cab
- Maximum allowable total mass
- Manufacturing year and month
- Manufacturing country
- Drive motor model
- Peak power
- Rated voltage of traction battery system
- Rated capacity
- Vehicle identification number (VIN)
- Manufacturer

Vehicle Parameters

Technical Data Dimensions

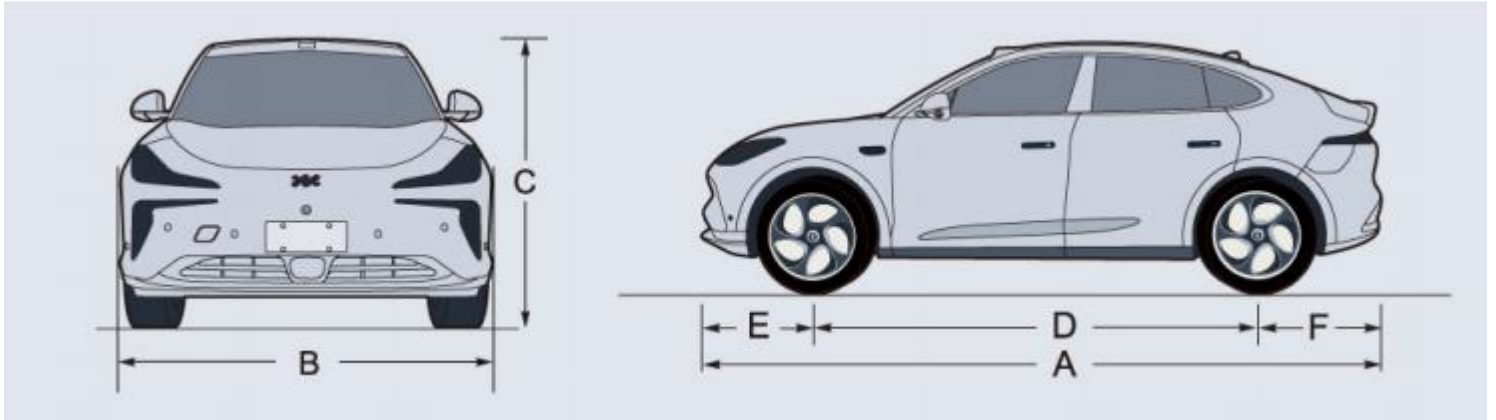

Item	Parameters			
	CSA6492LBEV2	CSA6492LBEV3	CSA6492LBEV5	CSA6492LBEV6
Overall length A, mm	4904			
Overall width B, mm	1988			
Overall height C (unladen), mm	1669			
Wheelbase D, mm	2950			
Front overhang E, mm	970			
Rear overhang F, mm	984			
Front wheel track, mm	1698			
Rear wheel track, mm	1707			
Minimum ground clearance (laden), mm	144			

Note: The vehicle length excludes license plate.

Note: Rearview mirrors and the deformed portion of tyre wall directly above the touchdown point are not included in the overall width.

Complete Vehicle Mass Parameters

Item	Parameters			
	CSA6492LBEV2	CSA6492LBEV3	CSA6492LBEV5	CSA6492LBEV6
Person in cab, person	5			
Unladen vehicle weight (kerb), kg	2432	2150	2227	2352/2322
Unladen front axle weight, kg	1216	1017	1055	1129/1114
Unladen rear axle weight, kg	1216	1133	1172	1223/1208
Gross vehicle weight, kg	2883	2601	2678	2803/2773
Laden front axle weight, kg	1324	1127	1163	1235/1221
Laden rear axle weight, kg	1559	1474	1515	1568/1552

Dynamic Parameters

Drive Motor Performance Parameters

Item	Front axle motor parameters	Rear axle motor parameters
Motor type	Permanent magnet synchronous motor	Permanent magnet synchronous motor
Rated power/peak power, kw	90/200 (800V-100kWh)	160/250 (400V-90kWh)
		150/231 (400V-71kWh)
		190/379 (800V-100kWh)
Peak torque, Nm	300	450 (400V)
		500 (800V)
Rated speed/Max. speed, rpm	14000/21000 (800V-100kWh)	8000/17000 (400V-90kWh)
		7000/17000 (400V-71kWh)
		14000/21000 (800V-100kWh)

Dynamic Performance Parameters

Item	Parameter		
	CSA6492LBEV2	CSA6492LBEV3 CSA6492LBEV5	and CSA6492LBEV6
Maximum speed, km/h	252	200	220
Gradeability, %	>35	>35	>35

Parameters of High-voltage Battery Pack

Item		Parameters		
		800V	400V	400V
		100kWh	90kWh	71kWh
Battery cell	Type	Ternary lithium ion battery	Ternary lithium battery	Ternary lithium ion battery
	Rated voltage, V	3.68	3.66	3.66
	Rated capacity, Ah	133.2	227.7	195
Battery pack	Number of battery packs	1	1	1
	Battery pack dimension, mm	2124*1433*166.2	1883*1439*149.5	1883*1439*136.2
	Voltage range, V	510.0-897.6	302.4-469.8	280.0-435.0
	Rated capacity, Ah	133.2	227.7	195
	Rated voltage, V	750.7	395	366
	Weight, kg	585	480	421
	IP rating	IP67	IP67	IP67

Recommended Fluids and Capacities

Name	Grade	Capacity
Coolant, L	Glycol (OAT)	18
Front electric drive unit fluid, L	Shell E-Fluids E6 iX	1.1
Rear electric drive unit fluid - 400V, L	Shell E-Fluids E6 iX	2.35
Rear electric drive unit fluid - 800V, L	Mobil 308	2.35
Brake fluid, L	DOT 4	0.8
Windscreen washer fluid, L	/	3.5
Air conditioning refrigerant, g	R-134a	960±20

Wheel and Alignment

Four-wheel alignment parameters (unladen)

		Parameter
Front wheels	Camber angle	$-15' \pm 45'$
	Castor angle	$5^{\circ}50' \pm 45'$
	Toe-in angle (total toe-in)	$12' \pm 15'$
	King pin inclination	$7^{\circ} \pm 45'$
Rear Wheels	Camber angle	$-1^{\circ} \pm 45'$
	Toe-in angle (total toe-in)	$12' \pm 15'$

Tyre Pressures (Cold)

Wheels	Unladen	Laden	ECO Mode - Unladen	ECO Mode - Laden
Front wheels	250 kPa/2.5 bar	250 kPa/2.5 bar	290 kPa/2.9 bar	290 kPa/2.9 bar
Rear Wheels	250 kPa/2.5 bar	280 kPa/2.8 bar	290 kPa/2.9 bar	290 kPa/2.9 bar

Tyre Size

Wheel Rim Size	Front 8J×20	Front 8.5J×21
	Rear 9J×20	Rear 10J×21
Tyre Size	Front 235/50 R20	Front 235/45 R21
	Rear 255/45 R20	Rear 265/40 R21